





1962

CORVETTE

SPECIFICATIONS

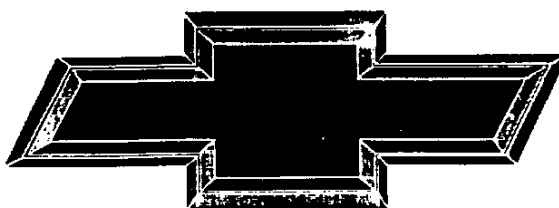
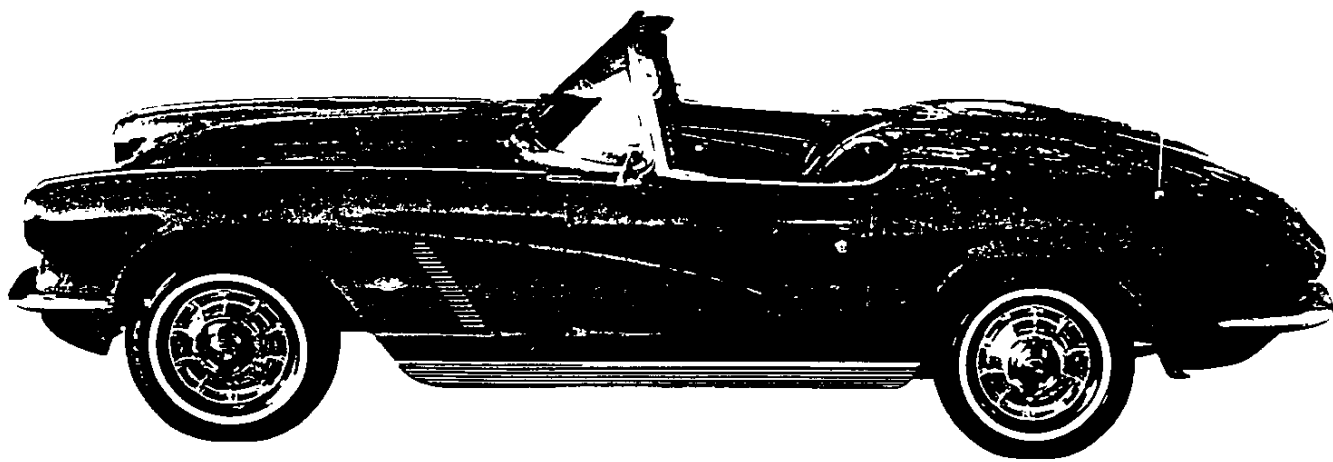

GENUINE CHEVROLET™



13

14



1962 CORVETTE

Production: 14,531 convertibles

1962 NUMBERS

Vehicle: 20867S100001 through 20867S114531

Suffix: RC: 327ci, 250hp, mt RF: 327ci, 360hp, mt
RD: 327ci, 300hp, mt SC: 327ci, 250hp, at
RE: 327ci, 340hp, mt SD: 327ci, 300hp, at

Block: 3782870: All

Head: 3782461: 327ci, 300hp, 340hp, 360hp 3795896: 327ci, 250hp
3884520: 327ci, 250hp, uu

Carburetor: Carter 3190S #3788245: 327ci, 250hp, at, ep
Carter 3191S #3788246: 327ci, 250hp
Carter 3310S #3819207: 327ci, 300hp, at
Carter 3269S #3797699: 327ci, 300hp(mt), 340hp

Fuel Injection: Rochester 7017355 (ep) Rochester 7017360

Distributor: 1110984: 327ci, 250hp, 300hp 1110990: 327ci, 360hp, ep
1110985: 327ci, 340hp 1111011: 327ci, 360hp

Generator: 1102174: 327ci, 250hp, 300hp
1102268: 327ci, 340hp, 360hp

Ending Vehicle: Aug 61: 100443 Jan 62: 106234 Jun 62: 113459
Sep 61: 100827 Feb 62: 107585 Jul 62: 114520
Oct 61: 102065 Mar 62: 109116 Aug 62: 114531
Nov 61: 103465 Apr 62: 110519
Dec 61: 104766 May 62: 112035

Abbreviations: at=automatic transmission, ci=cubic inch,
ep=early production, hp=horsepower, mt>manual transmission,
uu=uncertain usage.

1962 FACTS

- Engine displacement increased in 1962 from 283ci to 327ci. The base engine for 1962 had 250hp. Dual-four barrel carburetor engines available in Corvettes from 1956 to 1961, were not available in 1962.
- Styling for 1962 resembled 1961 strongly, but there were visual differences. The side cove lip on 1962s was formed by the fiberglass body panels, not accented by bright trim as previously. Because the trim was removed, 1962 Corvettes could not be ordered with coves painted to contrast overall body color.
- The simulated vent treatment in the cove area was changed in 1962 to a single louver, replacing the triple-spear vent.
- Conventional trunks last appeared in 1962 Corvettes. Models to follow had no external rear storage access until 1982 when a special "collector edition" model featured a hatch window.
- Other "lasts" for 1962 included last year for exposed headlights, solid rear axle, and optional power top.
- An aluminum case for the Powerglide automatic transmission was first introduced in 1962 Corvettes.
- This was the first year to have tires with narrow whitewalls (optional).
- Tachometers were distributor-driven in all 1962s. Previous use of tach-drive distributors in Corvette V8s was limited to fuel injected engines.
- The 250hp and 300hp engines had painted steel valve covers. The 340hp and 360hp engines had seven-fin cast alloy valve covers.
- Windshield washer reservoirs on 1962s mounted on the left side except for fuel injected engines. For fuel injected engines, reservoirs mounted on the right and were protected by heat shields.



1962 OPTIONS

CODE	DESCRIPTION	QTY	RETAIL \$
867	Base Corvette Convertible	14,531	\$4,038.00
102	AM Radio, signal seeking	13,076	137.75
203	Rear Axle, 3.08:1 ratio	—	0.00
242	Positive Crankcase Ventilation	—	5.40
276	Wheels, 15x5.5 (5)	561	0.00
313	Powerglide Automatic Transmission	1,532	199.10
396	327ci, 340hp Engine	4,412	107.60
419	Auxiliary Hardtop	8,074	236.75
426	Power Windows	995	59.20
441	Direct Flow Exhaust System	2,934	0.00
473	Power Operated Folding Top	350	139.90
488	24 Gallon Fuel Tank	65	118.40
582	327ci, 360hp Engine (fuel injection)	1,918	484.20
583	327ci, 300hp Engine	3,294	53.80
675	Positraction Rear Axle	14,232	43.05
685	4-Speed Manual Transmission	11,318	188.30
686	Metallic Brakes	2,799	37.70
687	Heavy Duty Brakes and Steering	246	333.60
1832	Whitewall Tires, 6.70x15	—	31.55
1833	Blackwall Tires, 6.70x15 nylon	—	15.70

- A 327ci, 250hp engine, 3-speed manual transmission, vinyl interior trim, and a soft top were included in the base price.
- Heaters became standard in 1962 for the first time, but could be factory-deleted with RPO 610. The 610 code specified "export," but other heater-deletes may have been built for racing.
- RPO 687 included special front and rear shocks, air scoops/deflectors for front brakes and air scoops for rear brakes, metallic brake facings, finned brake drums with cooling fans, and quick-steering adaptor. RPOs 582 and 675 were required.
- RPO 242 (pcv) was specified in order guides to be for California use.
- RPO 488 (24-gallon fuel tank) required hardtop without soft top because the tank occupied part of the folding top storage area.
- RPO 276 (15x5.5 wheels) included hubcaps (small) in place of standard full wheel discs.
- Base 3-speed manual transmissions were split 1,619 with 250hp/300hp engines, 62 with 340hp/360hp engines.
- The 1,532 RPO-313 quantity was split 1,067 with 250hp engines, 465 with 300hp engines.
- The 8,074 RPO-419 quantity included 3,179 in lieu of soft tops.
- The 11,318 RPO-685 quantity was split 5,050 with 250hp/300hp engines, 6,268 with 340hp/360hp engines.

1962 COLORS

EXTERIOR	QTY	SOFT TOP	WHEELS	INTERIOR
Tuxedo Black	—	Bk-W	Bk	Bk-F-R
Fawn Beige	1,851	Bk-W	Bk-Fb	F-R
Roman Red	—	Bk-W	Bk-R	Bk-F-R
Ermine White	—	Bk-W	Bk-W	Bk-F-R
Almond Beige	820	Bk-W	Bk-Ab	F-R
Sateen Silver	—	Bk-W	Bk-Si	Bk-R
Honduras Maroon	—	Bk-W	Bk-M	Bk-F

- Suggested interiors shown. Other combinations were possible.
- Generally, 1962s with whitewall tires had black wheels. Wheels combined with blackwall tires or RPO 276 were painted body color.
- Interior and exterior colors were not coded to individual cars. Other exterior colors, including primer only, were built. For example, Cadillac Royal Heather Amethyst (purple) is documented for a small number of 1962 Corvettes built for the Omaha Tangier Shrine Corvette Patrol.

Abbreviations: Ab=Almond Beige, Bk=Black, F=Fawn, Fb=Fawn Beige, M=Maroon, R=Red, Si=Silver, W=White.

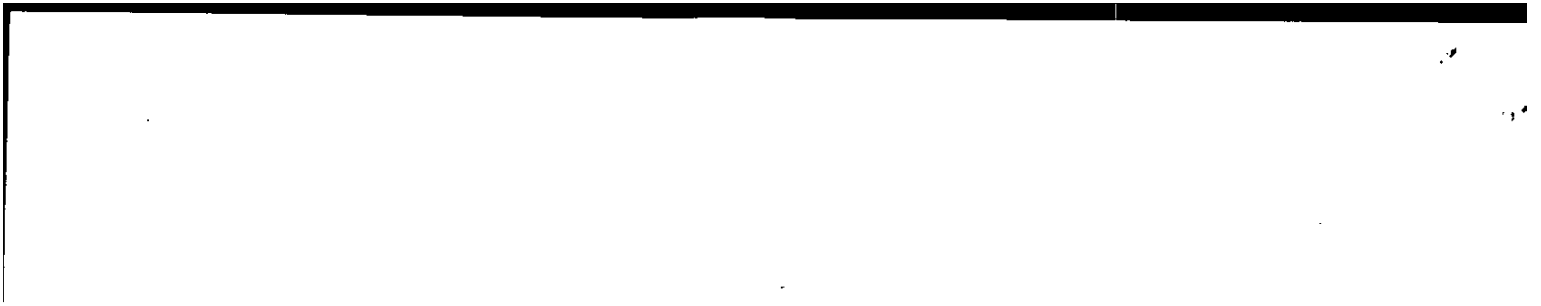

BLACK BOOK ORDER FORM

Send _____ copies of the

Corvette Black Book 1953-1992

@ \$11.95 each \$ _____

Ohio residents add .72 sales tax _____

Postage/hard shipping container 3.00

Check or money order enclosed \$ _____

Name _____

Street _____

City _____ State _____ Zip _____

Mail Order To: **Michael Bruce Associates, Inc.**
Post Office Box 396
Powell, Ohio 43065

BLACK BOOK ORDER FORM

Send _____ copies of the

Corvette Black Book 1953-1992

@ \$11.95 each \$ _____

Ohio residents add .72 sales tax _____

Postage/hard shipping container 3.00

Check or money order enclosed \$ _____

Name _____

Street _____

City _____ State _____ Zip _____

Mail Order To: **Michael Bruce Associates, Inc.**
Post Office Box 396
Powell, Ohio 43065



ORIGINAL

CORVETTE

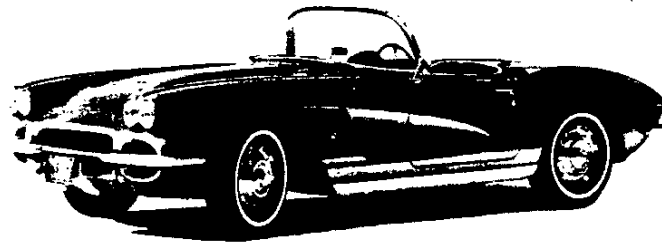

EXTERIOR-INTERIOR DIMENSIONS	2
REGULAR EQUIPMENT	4
OPTIONAL EQUIPMENT	5
EXTERIOR-INTERIOR COLORS	5
GENERAL CAR DATA	6
CHASSIS	6
HEAVY DUTY EQUIPMENT	8
POWER TEAM COMBINATIONS	9
ENGINES	10
TRANSMISSIONS	19
● ELECTRICAL	20

EXTERIOR - INTERIOR DIMENSIONS

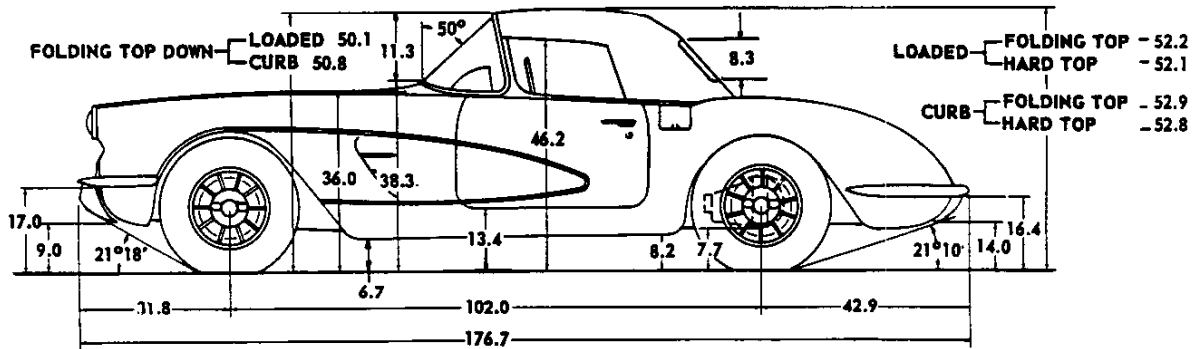
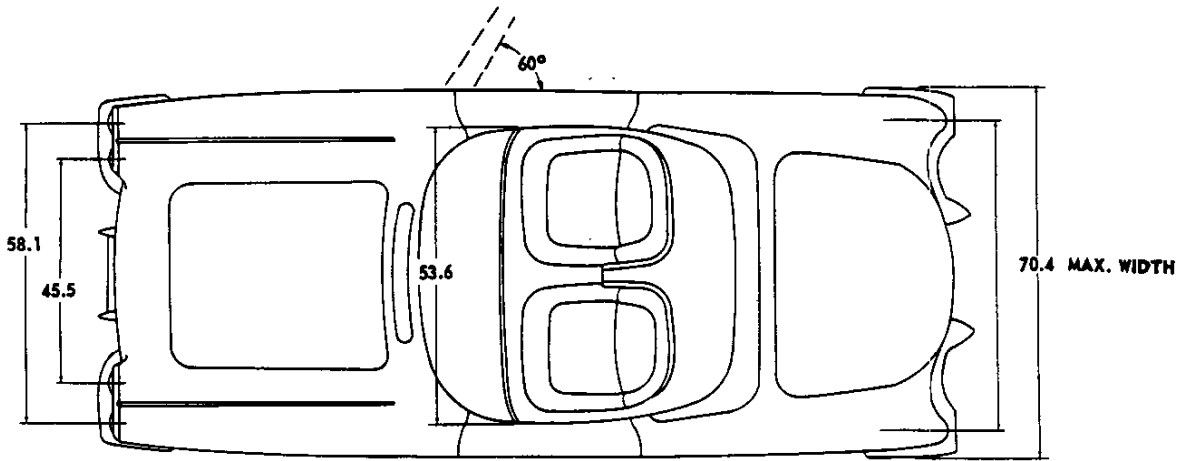

RAMP ANGLE - 7°47'

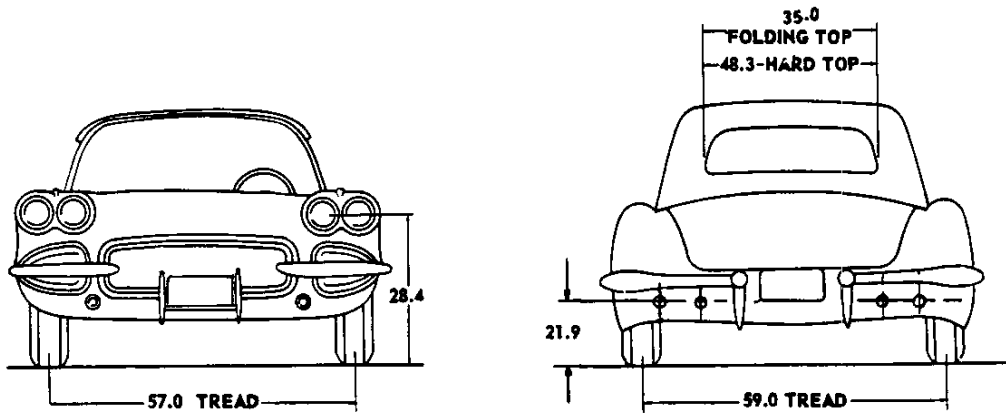

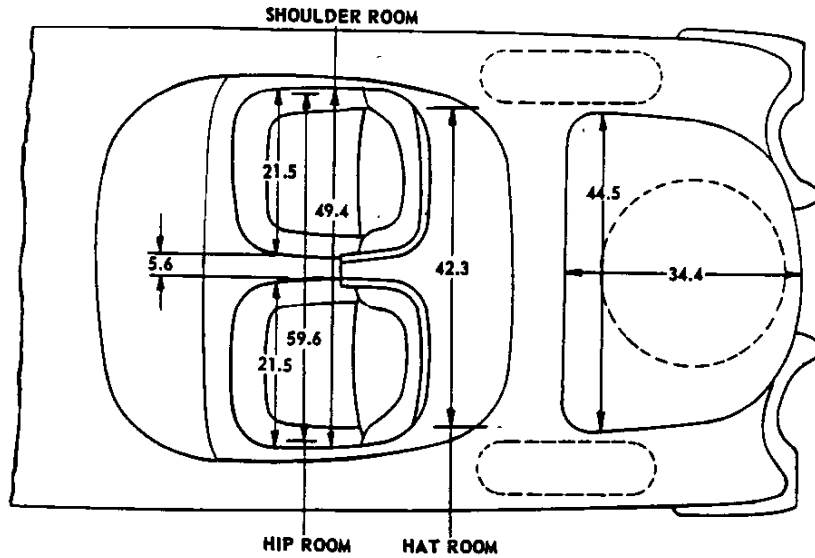

DRIVER SEAT ADJUSTMENT 4.4
 SEAT DIMENSIONS SHOWN ARE
 MEASURED 15" FROM CENTER
 LINE OF CAR WITH SEAT IN
 REAR POSITION

LUGGAGE SET CAPACITY - 5.2 CU. FT.
 OVERALL TRUNK CAPACITY - 12.1 CU. FT.

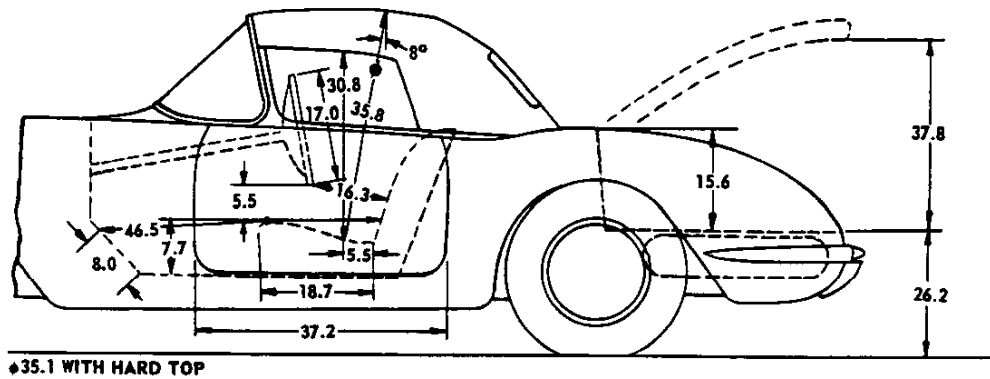

35.1 WITH HARD TOP

REGULAR EQUIPMENT

EXTERIOR		
Four Headlights with Painted Bezels		
Parking and Turn Signal Lights		
Twin Tail, Stop, and Turn Signal Lights		
Rear License Light		
Bright Metal	Parking Light Bezels	
	Front Fender Crown Molding	
	Grille Frame	
	Grille Guards and License Support	
	Front and Rear Bumpers	
	Cove Area Simulated Grille	
	Windshield Reveal Molding	
	Belt Reveal Molding	
	Door Glass Frames	
	Door Push-Button Handles	
	Door and Deck Lid Key Locks	
	Body Sill Molding	
	Tail Light Bezels	
	Rear License Frame	
	Hardtop Additional Moldings	Roof Front
		Drip Cap
		Quarter Window Reveal
	Rear Window Reveal	
	Hood Nameplate and Crossed Flags Ornament	
	Deck Lid Emblem	
Outside Rear View Mirror		
Wheel Disks		
Wheel Disk Ornaments		
Convertible Top		
Fender Side Emblem		
Gas Filler Door		

INTERIOR	
Three-Spoke Competition-Type Steering Wheel	
Vinyl Covered Instrument Panel	
160 MPH Speedometer, Odometer	
7000 RPM Tachometer	
Bright Metal	Cove Insert
	Sill Plates and Door Trim Moldings
	Step Plates
	Top Header Release Latches
Door Lock Lever	
Fuel, Temperature, Ammeter, Oil Pressure Gauges	
Ignition - Starter Switch	
Cigarette Lighter	
Cowl Vent Lever	
Hood Release Lever	
Rear View Mirror	
Ash Tray	
Electric Clock	
Cockpit Center Console	
Stowage Compartment	
Roll-Up Door Windows	
Twin Reflectors in Side Wall	
Door Armrests	
Glove Box with Key Lock	
Passenger Assist Bar-Padded	
Direction Signal Control	
Individually Adjusted Bucket Seats	
Seat Belts	
Ball-Type Door Handles	
Transmission Shift Lever and Shift Diagram Plate	
Headlight Dimmer Switch	
Windshield Wiper Control Knob	
Horn Button	
Dual Sunshades	
Windshield Washers	
Courtesy Light	
Parking Brake Alarm	
Deluxe Heater	

REGULAR PRODUCTION OPTIONS AND FACTORY OPTION ACCESSORIES

GROUP	ITEM	OPTION NUMBER	MODEL
Engine	300 Horsepower engine	583	867
	340 Horsepower engine	396	
	360 Horsepower engine	582	
	Special crankcase ventilation	242	
	Exhaust equipment, off road	441	
	Fiberglass fuel tank, 24 gallon	488	
Transmission	Powerglide transmission	313	
	Four-speed transmission	685	
Chassis	Rear axle, 3.08:1	203	
	Positraction rear axles	675	
	Brakes, heavy-duty (metallic)	686	
	Brakes, heavy-duty and special steering	687	
	Wheels, 15 x 5.50K	276	
	Tire, 6.70 x 15-4 PR (w/w, rayon)	1832	
	Tire, 6.70 x 15-4 PR (nylon)	1833	
Body	Power windows	426	
	Hardtop, auxiliary	419	
	Folding top, hydraulic	473	
	Folding top equipment	470	
	Radio, signal seeking	102	

EXTERIOR-INTERIOR COLOR COMBINATIONS

EXTERIOR		INTERIOR
Solid Colors, Wheels* and Optional Hardtop	Convertible Top	Trim and Paint
Tuxedo Black	Black, White	Fawn
Ermine White		Red
		Black
Roman Red		Fawn
		Red
Sateen Silver		Black
		Red
Fawn Beige		Black
		Fawn
Almond Beige		Red
	Fawn	
Honduras Maroon	Fawn	
	Black	

* Wheels are black when optional white sidewall tires are specified.

GENERAL CAR DATA

VEHICLE SERIAL NUMBER

Model year 1962 code ----- 2
 Model 867 code ----- 0867
 Assembly plant code ----- Designated by letter
 Unit number code ----- 10000 followed by unit number

Unit number 3, 1962 Model 867, built in St. Louis,
 would bear serial number 20867 S 100003

REAR AXLE IDENTIFICATION

Type and Designation for standard combinations
 3-Speed, 4-Speed and Powerglide with 3.36:1 rear
 axle ratio ----- CA
 4-Speed with 3.70:1 rear axle ratio ----- CG

ENGINE IDENTIFICATION

Type and Designation
 250 HP engine with 3 or 4-speed ----- RC
 300 HP engine with 3 or 4-speed ----- RD
 340 HP engine with 3 or 4-speed ----- RE
 360 HP engine with 3 or 4-speed ----- RF
 250 HP engine with Powerglide ----- SC
 300 HP engine with Powerglide ----- SD

VEHICLE WEIGHTS (lb), 250 HP ENGINE *

3-Speed Transmission
 Shipping -----2925
 Curb -----3060
 Design -----3360
 4-Speed Transmission
 Shipping -----2940
 Curb -----3075
 Design -----3375
 Powerglide
 Shipping -----2940
 Curb -----3075
 Design -----3375
 Optional Hardtop ----- 55

* - See Passenger car "DIMENSIONS AND WEIGHTS"
 section for definitions of weights.

BODY GLASS

Total Area (Soft Top) ----- 1816 sq. in.
 Windshield ----- Laminated safety glass
 Side doors ----- Safety solid plate
 Fabric top rear window ----- Vinyl plastic
 Hardtop rear and quarter windows ----- Plexiglass

CHASSIS

FRONT WHEEL ALIGNMENT

Camber ----- $0^{\circ} \pm 0^{\circ}30'$
 Caster ----- $2^{\circ} \pm 0^{\circ}30'$
 King pin inclination ----- $3^{\circ}30' - 4^{\circ}30'$
 Toe in ----- 0-.12

FRAME

Make & type - Chevrolet, box girder with "X" member
 Maximum overall length ----- 140.63
 Maximum overall width ----- 58.00
 Number of crossmembers including "X" member --- 3
 Body mounting points ----- 10
 Material ----- Hot rolled steel
 Side member section modulus (in³) ----- 1.677
 Moment of inertia (in⁴) ----- 4.930

KING PINS

Diameter ----- .8660-.8665
 Bushings
 Inside diameter ----- .867-.868
 Length ----- 1.312

WHEEL TRAVEL-FRONT

Jounce ----- 3.33
 Rebound ----- 3.19

WHEEL TRAVEL-REAR

Jounce ----- 3.94
 Rebound ----- 3.90

STEERING KNUCKLE

Type ----- Reverse Elliot
 Spindle diameter:
 At inner bearing ----- 1.2810-1.2815
 At outer bearing ----- .7498-.7503
 Thread size ----- 3/4-20

FRONT SPRINGS

Type ----- Coil
 Material and gauge --- Chrome alloy steel .547-.550
 Number of coils ----- Total 9.75; active 7.94
 Diameter ----- Outside 4.30; pitch 3.752
 Height ----- Free 13.75; working 9.62 @ 1235 lb.
 Height under curb weight ----- 9.72
 Capacity at ground ----- 800 lb.
 Deflection rate
 At spring ----- 300 lb/in.
 At wheel ----- 110 lb/in.

FRONT SHOCK ABSORBERS ϕ

Make and type ----- Delco, direct double acting
 Mounting ----- Vertically from lower control arm
 through coil spring to front suspension crossmember
 Piston diameter and travel ----- 1.00 x 4.68

ϕ - Contains nitrogen-filled envelope in fluid reservoir

CHASSIS (CONTINUED)

STABILIZER BAR, FRONT

Type ----- Link
 Material ----- Hot rolled steel
 Diameter ----- .8125

REAR SPRINGS

Type ----- Semi-elliptical
 leaf, outrigger mounted.
 Material ----- Chrome carbon steel
 Size
 Length under nominal load ----- 51.0
 Nominal width ----- 2.0
 Number of Leaves ----- 4
 Leaf Liners
 Number ----- 3
 Size ----- 19.8, 31.8 & 46.3 x 1.9 x .11
 Material ----- Wax impregnated fibre board
 Type of Mounting Insulation ----- Rubber bushed
 Spring Rate (in-lb) ----- 115
 Design Height ----- .08 negative
 camber under load of 545-605 lbs.

REAR SHOCK ABSORBERS[♠]

Make & Type ----- Delco, direct double acting
 Mounting ----- Stern attached to slotted
 holes in flanged "U" shaped rear crossmember, eye
 attached at bottom to an anchor bolt on rear spring
 "U" bolt and shock absorber anchor bolt plate.
 Piston Diameter and Travel ----- 1.0 x 7.44

STABILIZER BAR, REAR

Type ----- Link
 Material ----- Hot rolled steel
 Diameter ----- .625

REAR RADIUS RODS

Location ----- Outrigger mounted
 to top of outer ends of axle, near the brake backing
 plates, and to frame forward of the axle.
 Size
 Length ----- 18.28
 Diameter ----- .750
 Number of Rods ----- 2

DRIVE LINE

Type ----- Hotchkiss drive,
 one propeller shaft. Torque and thrust taken through
 rear springs and radius rods.

BRAKING-PARKING

Type of control ----- "T" handle pull rods
 Location of control ----- LH of steering column
 Operates on ----- Rear service brakes

BRAKES-SERVICE

Type ----- Duo-servo, 4 wheel hydraulic
 Brake Size
 Front ----- 11 x 2
 Rear ----- 11 x 1.75
 Brake Drums
 Diameter, front & rear ----- 11
 Swept drum area (sq in) ----- 259
 Lining sizes (length x width x thickness) ●
 Front-Primary ----- 9.34 x 2.0 x .168
 -Secondary ----- 11.75 x 2.0 x .164
 Rear -Primary ----- 9.34 x 1.75 x .168
 -Secondary ----- 11.75 x 1.75 x .164
 Total effective area (sq in) ----- 157
 Percent braking effort - front ----- 58.5%
 Wheel cylinder bore
 Front ----- 1.1875
 Rear ----- 1.000
 Master cylinder bore ----- 1.000
 Pedal travel ----- 4.50
 Shoe clearance adjustment ----- Adjust
 to light drag and back off seven notches.
 Capacity (pints) ----- .66
 Braking ratios●
 Pedal ----- 4.10:1
 Hydraulic ----- 4.82:1
 Overall ----- 19.76:1

* STEERING

Steering Gear Ratio ----- 16:1
 Steering Wheel Diameter ----- 17.00
 Turning Diameters
 Right-wall to wall ----- 38.5 ft
 Left-wall to wall ----- 39.0 ft
 Right-curb to curb ----- 36.5 ft
 Left-curb to curb ----- 37.0 ft
 Overall Steering Ratio ----- 21.0:1
 Number of wheel turns (lock to lock) ----- 3.70

TACHOMETER

Make ----- AC
 Model ----- W
 Type ----- Mechanical
 Driven Off ----- Distributor

WHEELS

Rim Size & Flange Type ----- 15 x 5K
 Attachment to Hub ----- 5-7/16-20
 studs on a 4.75 diameter bolt circle

TIRES

Size ----- 6.70 x 15-4pr
 Type ----- Blackwall rayon tubeless
 Revolutions/Mile @ 30 MPH ----- 760
 Inflation Pressure (front and rear) ----- 24 lb

♠ - Contains nitrogen-filled envelope in fluid reservoir.

* - Special Steering Adapter, see Page 8

HEAVY DUTY BRAKE EQUIPMENT-RPO 686-RPO 687

RPO 686 METALLIC SERVICE BRAKES

Same as Regular Production Service Brakes except as follows:

- Brake Drum
- Swept drum area (sq. in.) ----- 327.0
- Brake Lining
- Material ----- Sintered iron segments
- Size
- Front wheel segments
- Primary ----- 1.64 x 1.37 x .210
 - Secondary ----- 1.64 x 1.37 x .330
- Rear wheel segments
- Primary ----- 2.00 x 1.00 x .210
 - Secondary ----- 2.00 x 1.00 x .330
- Segments per shoe
- Primary shoe, front and rear wheels ----- 6
 - Secondary shoe, front and rear wheels ----- 10
- Method of attachment ----- Welded
- Clearance ----- Adjust to light drag, back off 12 notches
- Total effective area (sq. in.) ----- 134

RPO 687 METALLIC SERVICE BRAKES, SPECIAL STEERING ADAPTER, HEAVY-DUTY SHOCK ABSORBERS

SERVICE BRAKES - Same as Regular Production Service Brakes except as follows:

- Brake Drum
- Rim ----- Cooling vanes in incorporated; air scoop attached to backing plate
- Swept drum area (sq. in.) ----- 294.0
- Brake Lining
- Material ----- Sintered iron segments
- Size
- Front wheel segments
- Primary ----- 1.64 x 1.25 x .205
 - Secondary ----- 1.64 x 1.25 x .325
- Rear wheel segments
- Primary ----- 2.00 x .875 x .205
 - Secondary ----- 2.00 x .875 x .325
- Segments per shoe
- Primary shoe, front and rear wheels ----- 6
 - Secondary shoe ----- 10
- Method of attachment ----- Welded
 - Clearance ----- Adjust to light drag, back off 17 notches
- Total effective area (sq. in.) ----- 126
- Distribution of braking effort (theo. %)
- Front ----- 62
- Wheel cylinders
- Front, inside dia ----- 1.125
 - Rear, inside dia ----- .875

SPECIAL STEERING ADAPTER

- Overall Ratio ----- 16.3:1
- Number of wheel turns (lock to lock) ----- 3.25

RPO 675 POSITRACTION REAR AXLES

Ratios Available	Gear Set
3.08:1	12, 37
3.36:1	11, 37
● 3.55:1	9, 32
3.70:1	10, 37
4.11:1	9, 37
4.56:1	9, 41

POWER TEAM COMBINATIONS

327 CUBIC INCH V-8 ENGINES	CARBURETION	TRANSMISSION	REGULAR AXLES	POSITRACTION AXLES
250 HORSEPOWER	4-BARREL	3-SPEED	3.36:1	3.36:1
		4-SPEED	3.08:1*, 3.36:1	3.08:1, 3.36:1
		POWERGLIDE	3.36:1	3.36:1
300 HORSEPOWER (RPO 583)	LARGE 4-BARREL	3-SPEED	3.36:1	3.36:1
		4-SPEED	3.08:1*, 3.36:1	3.08:1, 3.36:1
		POWERGLIDE	3.36:1	3.36:1
340 HORSEPOWER (RPO 396)	LARGE 4-BARREL SPECIAL CAM	3-SPEED	3.36:1 **	3.36:1 3.08:1 3.55:1
		4-SPEED	3.70:1	3.70:1 4.11:1 4.56:1
		3-SPEED	3.36:1 **	3.36:1 3.08:1 3.55:1
		4-SPEED	3.70:1	3.70:1 4.11:1 4.56:1
360 HORSEPOWER (RPO 582)	FUEL INJECTION SPECIAL CAM	3-SPEED	3.36:1 **	3.36:1 3.08:1 3.55:1
		4-SPEED	3.70:1	3.70:1 4.11:1 4.56:1
		3-SPEED	3.36:1 **	3.36:1 3.08:1 3.55:1
		4-SPEED	3.70:1	3.70:1 4.11:1 4.56:1

* - OPTIONAL
 ● ** 3.36:1 POSITRACTION AXLE AVAILABLE

MANUAL TRANSMISSION MULTIPLICATION FACTORS

Engine	Transmission	Axle Ratio	Total Gear Reduction					⊙ Max Axle Torque-Low Gear (lb-ft)
			1st	2nd	3rd	4th	Rev	
250 HP	3-speed	3.36:1	8.30	5.14	3.36		9.41	2222
300 HP								
340 HP								
360 HP								
250 HP	4-speed (2.54 1st)	3.36:1	8.53	● 6.35	5.07	3.36	8.77	2294
300 HP								
340 HP	4-speed (2.20 1st)	3.70:1	8.14	● 6.07	4.85	3.70	8.36	
360 HP								

AUTOMATIC TRANSMISSION MULTIPLICATION FACTORS

Engine	Transmission	Selector Position	* Total Torque Multiplication	Axle Ratio
250 HP	Powerglide	Drive	12.43:1-3.36:1	3.36:1
300 HP		Low and reverse	12.43:1- 5.93:1	

⊙ - Gear reduction x maximum net engine torque x efficiency (.9 direct drive, .85 all others).
 * - Axle ratio x transmission ratio.

CORVETTE ENGINES

GENERAL ENGINE DATA

ENGINE		3-Speed	4-Speed	Powerglide
Displacement (Cubic Inches)		327		
Type		V-8 Valve-in-head		
Bore and stroke		4.00 x 3.25		
Compression ratio		10.5:1-Standard and 300 HP; 11.25:1-340 and 360 HP		
Taxable (SAE) horsepower		51.2		
● Idling speed (RPM)		500 (Neutral) @		475 (Drive)
Lubrication		Full pressure		
Power plant mounting		Three point, two front, one rear, Compression type		
Overall Measurements	Length (not including transmission)	36.57		31.66
	Width	26.72		
	Height	29.54		
Cylinder Designation				
		Firing order: 1-8-4-3-6-5-7-2		

● @ 700 Neutral for 340 and 360 HP Engines

ADVERTISED MAXIMUM ENGINE PERFORMANCE

Engine		Standard	300 HP	340 HP	360 HP
Brake Horsepower	Net	210 @ 4400 RPM			
	Gross	250 @ 4400 RPM	300 @ 5000 RPM	340 @ 6000 RPM	360 @ 6000 RPM
Torque (Lb-Ft)	Net	315 @ 2600 RPM			
	Gross	350 @ 2800 RPM	360 @ 3200 RPM	344 @ 4000 RPM	352 @ 4000 RPM

ENGINE SPEED AND PISTON TRAVEL

Transmission	3-Speed	Powerglide*	4-Speed (2:54 Low)		
Rear Axle Ratio	3.36:1	3.36:1	3.08:1		3.36:1
Tire Size	6.70 x 15-4 PR				
Crankshaft Rev/Mile in Direct Drive	2553.6	2553.6	2347.0	2553.6	
Crankshaft Rev/Min @ 1 Mile/Hr	Low	105.1	77.5	99.1	108.1
	Second	65.1		73.74	80.44
	Third	42.6	Direct 42.6	58.9	64.3
	Fourth			39.0	42.6
	Reverse	119.2	77.5	101.8	111.1
Piston Travel Ft/Mile in Direct Drive	1383.3	1383.3	1271.4	1383.3	
Transmission	4-Speed (2.20 Low)				
Rear Axle Ratio	3.08:1	3.55:1	3.70:1	4.11:1	4.56:1
Tire Size	6.70 x 15-4 PR				
Crankshaft Rev/Mile in Direct Drive	2347.0	2698.0	2812.0	3123.6	3465.6
Crankshaft Rev/Min @ 1 Mile/Hr	Low	85.8	98.9	103.1	114.6
	Second	63.97	73.73	76.85	85.36
	Third	51.1	58.9	61.4	68.2
	Fourth	39.0	45.0	46.9	52.1
	Reverse	88.2	101.6	105.9	117.7
Piston Travel Ft/Mile in Direct Drive	1271.4	1461.5	1523.3	1692.1	1877.3

* - Zero slippage assumed.

October 1961 ● Revised January 1962

10-CORVETTE

1962 CHEVROLET PASSENGER CAR

ADVERTISED CAR PERFORMANCE FACTORS

ENGINE	Horsepower	250	300	340	360
	Carburetor	4-bbl	Large 4-bbl	Large 4-bbl	Fuel Injection
	Camshaft	Regular	Regular	Special	Special

3-Speed Transmission with 3.36:1 Rear Axle

Performance weight (pounds)	3360	3360	3340	3370
Pounds per gross horsepower	13.44	11.20	9.82	9.36
Pounds per Cu In displacement	10.28	10.28	10.21	10.31
Gross horsepower per Cu In displacement	.765	.917	1.040	1.101
Power displacement (Cu Ft/mile)	241.6	241.6	241.6	241.6
Displacement factor (Cu Ft/ton mile)	143.8	143.8	144.7	143.4

4-Speed Transmission with 3.36:1 Rear Axle

Performance weight (pounds)	3375	3375	3355	3385
Pounds per gross horsepower	13.50	11.25	9.87	9.40
Pounds per Cu In displacement	10.32	10.28	10.26	10.35
Gross horsepower per Cu In displacement	.764	.917	1.040	1.101
Power displacement (Cu Ft/mile)	241.6	241.6	241.6	241.6
Displacement factor (Cu Ft/ton mile)	143.0	143.0	144.0	142.7

Powerglide Transmission with 3.36:1 Rear Axle

Performance weight (pounds)	3375	3375	
Pounds per gross horsepower	13.50	11.25	
Pounds per Cu In displacement	10.32	10.32	
Gross horsepower per Cu In displacement	.764	.917	
Power displacement (Cu Ft/mile)	241.6	241.6	
Displacement factor (Cu Ft/ton mile)	143.0	143.0	

Performance Weight = Curb Weight plus 300 Lb (weight of two 150 Lb passengers)
Power Displacement = $\frac{(\text{Crankshaft Revs/Mi} \times \text{Piston Displacement})}{2 \times 1728}$
Displacement Factor = $\frac{\text{Power Displacement}}{\text{Performance Wt (tons)}}$

POWER CURVES

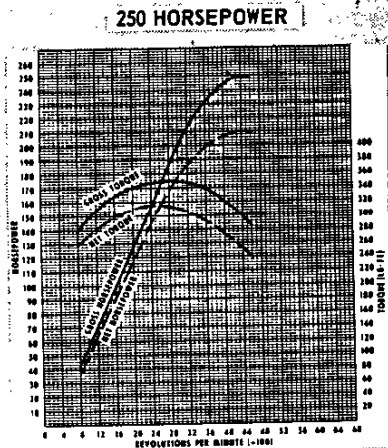

300 HORSEPOWER

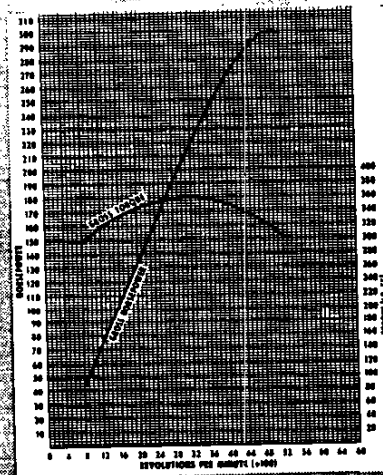

The engine performance curves represent full throttle performance as obtained from dynamometer test data corrected to standard barometric pressure 29.92 inches of mercury and standard temperature of 60°F.

GROSS POWER and TORQUE were obtained in a regular dynamometer test with the dynamometer exhaust

system, no fan, generator not charging, optimum spark advance, and optimum fuel setting.

NET POWER and TORQUE were obtained from a dynamometer test simulating actual operating conditions when the engine is in its vehicle, except the generator is not charging.

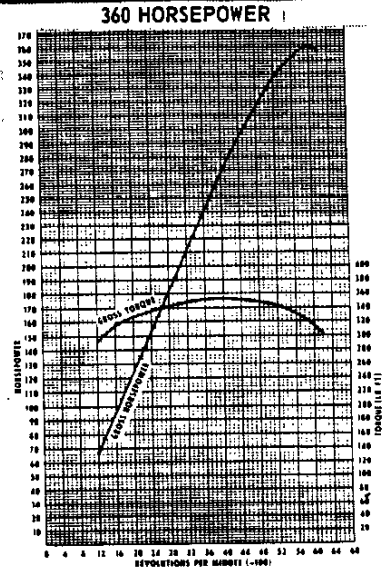
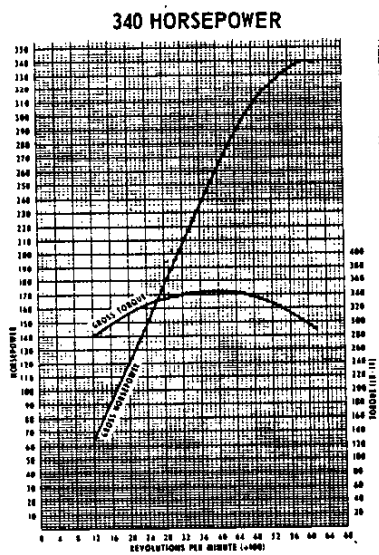

ENGINES-Cont'd.

250 HORSEPOWER
4-BARREL CARBURETOR
(STANDARD ENGINE)

SAME AS PASSENGER CAR 250 HORSEPOWER ENGINE WITH
4-BARREL CARBURETOR (RPO 300) EXCEPT FOR THE
FOLLOWING DIFFERENCES

FUEL SYSTEM

FUEL TANK

Capacity (gallons) ----- 16.4
● Filler Location ----- Rear of left door opening

● FUEL FILTER

Location ----- Fuel tank outlet
Type ----- Plastic mesh
Location ----- Carburetor inlet
Type ----- Sintered bronze

CARBURETOR

Model
Powerglide ----- 3788246

AIR CLEANER

Type ----- Low silhouette, louvered
cannister of polished aluminum; oil-wetted, poly-
urethane element.

LUBRICATION SYSTEM

CRANKCASE CAPACITY (Qts.)

Refill ----- 5.0
● Refill With Filter Change ----- 6.0

COOLING SYSTEM

GENERAL

Capacity (qts.)
Without Heater ----- 15.5
With Heater ----- 16.5

RADIATOR

Make and Type ---- Harrison, aluminum, cross flow
Core Constant ----- .18 x .556
Core Thickness ----- 2.88
Frontal Area (sq. inches) ----- 315.4
Model ----- 3150916

RADIATOR CAP

Vacuum Valve Characteristics ----- Opens
at .62 psi max.

COOLING FAN

OD ----- 17.12

BELT - CRANKSHAFT, FAN AND GENERATOR

Number Used ----- 1
Pitch Line Length ----- 55.5
Generator Pulley PD ----- 3.62

EXHAUST SYSTEM

GENERAL

Resonators ----- None
Exhaust Pipe Wall Thickness ----- .0747

ELECTRICAL SYSTEM

GENERATOR

Model ----- Delco-Remy, 1102174
Rating (Amp) ----- 35
Ratio, Generator to Engine ----- 1.84
Drive ----- Crankshaft pulley
Engine RPM @ Max. Generator Output ----- 1647

COIL

Model ----- Delco-Remy, 1115091

DISTRIBUTOR

Model ----- Delco-Remy, 1110984

TACHOMETER

Model ----- 1549601

CLUTCH (FOR 3 AND 4-SPEED TRANSMISSIONS)

Same as clutch for Passenger Car 380 and 409 HP
Engines (RPO 580 and 587) except for the following
differences:

CLUTCH

Clutch Spring
Effective Plate Load (lb.) ----- 2000-2300
Driven Plate
Friction Facing
OD ----- 10.0
ID ----- 6.5
Total Area (sq. inches) ----- 90.68

**300 HORSEPOWER
LARGE 4-BARREL CARBURETOR
(RPO 583 ENGINE)**

ENGINES-Cont'd.

**SAME AS CORVETTE 250 HORSEPOWER ENGINE EXCEPT FOR
THE FOLLOWING DIFFERENCES**

PRINCIPAL COMPONENTS

CYLINDER HEAD
Combustion Chamber Volume (cubic inches)-4.5963

● **EXHAUST MANIFOLD**
Outlet Diameter (nominal) ----- 2.50

VALVES
Intake
Head Dia ----- 1.935-1.945

FUEL SYSTEM

● **FUEL FILTER**
Location ----- Between fuel
pump and carburetor
Type ----- Glass bowl with paper element

CARBURETOR
Make ----- Carter
Type and Material --- Aluminum 4-barrel (AFB),
downdraft
Model
Manual and Powerglide ----- 3797699
SAE Carburetor Size (Throttle Body) ----- 1-1/2
Venturi Dia.
Primary ----- 1.25
Secondary ----- 1.5625
Throttle Bore
Primary ----- 1.5625
Secondary ----- 1.6875

EXHAUST SYSTEM

GENERAL
Type ----- Dual with crossover balance pipe

CLUTCH (FOR 3 AND 4-SPEED TRANSMISSIONS)

CLUTCH-Same as clutch for 250 HP Corvette engine

**340 HORSEPOWER
LARGE 4-BARREL CARBURETOR
SPECIAL CAM
(RPO 396 ENGINE)**

**SAME AS CORVETTE 250 HORSEPOWER ENGINE EXCEPT FOR
THE FOLLOWING DIFFERENCES**

PRINCIPAL COMPONENTS

CYLINDER HEAD
● Combustion Chamber Volume (Cu. In.) ----- 3.9458

● **EXHAUST MANIFOLD**
Outlet Diameter (Nominal) ----- 2.50

● **CRANKSHAFT**
Crankshaft pulley
Type ----- Dual

CAMSHAFT

Lobe Lift
Intake ----- .2625
Exhaust ----- .2665

VALVE TRAIN

Lifter Type ----- Mechanical
Push Rods
Ends ----- Valve rocker
arm end has welded on hardened tip

● Revised January 1962 October 1961
CORVETTE -15

1962 CHEVROLET PASSENGER CAR

VALVES

Intake
Head Dia ----- 1.935-1.945
Exhaust
Tip Material ----- Silichrome #1
Coating ----- Induction aluminized head and face

VALVE LIFT

Intake ----- .39375
Exhaust ----- .39975

VALVE LASH

Inlet ----- .012
Exhaust ----- .018

VALVE TRAIN TIMING (INCLUDING RAMPS)

Intake (.012 Lash)
Opens ----- 35° BTC
Closes ----- 72° ABC
Duration ----- 287°
Exhaust (.018 Lash)
Opens ----- 76° BBC
Closes ----- 31° ATC
Duration ----- 287°
Overlap ----- 66°

PISTON

Head Type ---- Impact Extruded Aluminum, Domed
Top Land Clearance ----- .0178-.1213
Skirt Clearance ----- .0013-.0015

INLET MANIFOLD

Material ----- Aluminum

FUEL SYSTEM

FUEL FILTER

Location ----- Between fuel pump and carburetor
Type ----- Bowl with paper element

CARBURETOR

Make ----- Carter
Type ----- Aluminum
4-barrel (AFB), downdraft
Model ----- 3797699
SAE Carburetor Size (Throttle Body) ----- 1-1/2
Venturi Dia.
Primary ----- 1.25
Secondary ----- 1.5625
Throttle Bore
Primary ----- 1.5625
Secondary ----- 1.6875

LUBRICATION SYSTEM

GENERAL

Oil Filler
Cap ----- Solid

COOLING SYSTEM

BELT - CRANKSHAFT, FAN AND GENERATOR

Generator Pulley PD ----- 4.00

BELT-CRANKSHAFT, WATER PUMP AND IDLER

Number used ----- 1
Angle of "V" (degrees) ----- 39-41
Pitch line length ----- 38.00
Width ----- .380

WATER PUMP

Water pump pulley
Type ----- Dual
Idler PD ----- 2.88

EXHAUST SYSTEM

GENERAL

Type ----- Dual with crossover balance pipe

ELECTRICAL SYSTEM

GENERATOR

Model ----- 1102268
Ratio, Generator to Engine ----- 1.66
Engine RPM @ Max. Generator Output ----- 1825

DISTRIBUTOR (Dual points, no vacuum advance)

Model ----- 1110985
Cam angle (per breaker) ----- 29°
Total cam angle (both breakers) ----- 34°

TACHOMETER

Model ----- 1549082

CLUTCH (FOR 3 AND 4-SPEED TRANSMISSIONS)

CLUTCH -- Same as clutch for Corvette 250 HP engine

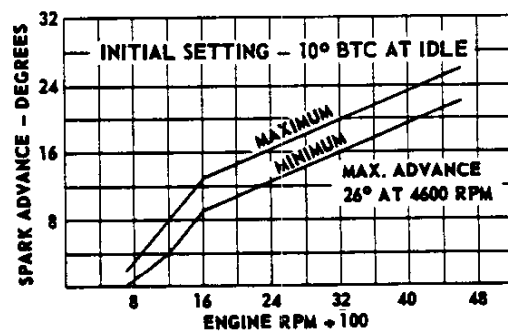

**360 HORSEPOWER
FUEL INJECTION
SPECIAL CAM
(RPO 582 ENGINE)**

ENGINES-Cont'd.

SAME AS CORVETTE 250 HORSEPOWER ENGINE EXCEPT FOR THE FOLLOWING DIFFERENCES

PRINCIPAL COMPONENTS

CYLINDER HEAD

● Combustion Chamber Volume (Cu. In.) ----- 3.9458

● **EXHAUST MANIFOLD**

Outlet Diameter (Nominal) ----- 2.50

CAMSHAFT

Lobe Lift

Intake ----- .2625

Exhaust ----- .2665

VALVE TRAIN

Lifter Type ----- Mechanical

Push Rods

Ends ----- Valve rocker arm end has welded on hardened tip

VALVES

Intake

Head Dia. ----- 1.935-1.945

Exhaust

Tip Material ----- Silichrome #1

Coating ----- Induction aluminized head and face

VALVE LIFT

Intake ----- .39375

Exhaust ----- .39975

VALVE LASH

Intake ----- .012

Exhaust ----- .018

VALVE TRAIN TIMING

Intake (.012 Lash)

Opens ----- 35° BTC

Closes ----- 72° ABC

Duration ----- 287°

Exhaust (.018 Lash)

Opens ----- 76° BBC

Closes ----- 31° ATC

Duration ----- 287°

Overlap ----- 66°

PISTON

Head Type ----- Impact extruded aluminum, domed

Top Land Clearance ----- .0178-.0213

Skirt Clearance ----- .0013-.0015

● **CRANKSHAFT**

Crankshaft pulley

Type ----- Dual

LUBRICATION SYSTEM

GENERAL

Oil Filler

Cap ----- Solid

COOLING SYSTEM

BELT - CRANKSHAFT, FAN AND GENERATOR

Generator Pulley PD ----- 4.00

● **BELT-CRANKSHAFT, WATER PUMP AND IDLER**

Number used ----- 1

Angle of "V" (degrees) ----- 39-41

Pitch line length ----- 38.00

Width ----- .380

● **WATER PUMP**

Water pump pulley

Type ----- Dual

Idler PD ----- 2.88

EXHAUST SYSTEM

GENERAL

Type ----- Dual with crossover balance pipe

ELECTRICAL SYSTEM

GENERATOR

Model ----- 1102268

Radio, Generator to Engine ----- 1.66

Engine RPM @ Max. Generator Output ----- 1825

COIL

Model ----- 1115107

DISTRIBUTOR (Dual points, no vacuum advance)

● Model ----- 1111011

Cam angle (per breaker) ----- 29°

Total cam angle (both breakers) ----- 34°

TACHOMETER

Model ----- 1549082

CLUTCH (FOR 3 AND 4-SPEED TRANSMISSIONS)

CLUTCH ----- Same as clutch for Corvette 250 HP Engine

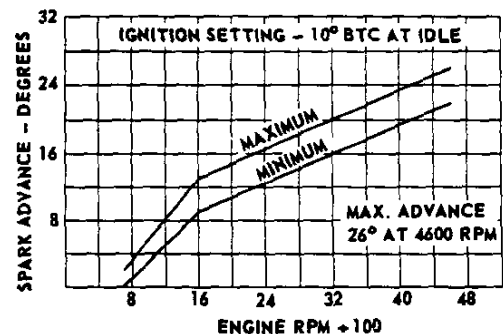

● Revised January 1962 October 1961
CORVETTE-17

FUEL INJECTION SYSTEM

GENERAL

Make ----- Rochester
 Type ----- Constant Flow
 Model ----- 7017360

AIR CLEANER

Location ----- On left fender skirt
 Air Intake Duct ----- Channel Air
 from air cleaner to air meter adapter

AIR INDUCTION

Description ----- Air metering system
 with plenum chamber and ram pipes

Location

Plenum Chamber and Ram Pipes ----- Integral
 with intake manifold

Air Metering Assembly ----- Left side
 of intake manifold

Ram Pipes

Number ----- 8
 Length ----- 12.0

AIR/FUEL RATIO CONTROL

Devices ----- Vacuum sensitive diaphragms
 for fuel cut-off (coasting), normal operation and
 enrichment (acceleration); fast start solenoid for
 starting and electric choke for warm-up.

Choke

Current Draw ----- 1 Amp. @ 70° F

FUEL METER PUMP

Type ----- Gear
 Drive ----- Flexible shaft from distributor

INTAKE MANIFOLD AND ADAPTER

Description ----- Each one piece
 die cast aluminum construction

FUEL FILTER

Make ----- AC
 Model ----- GF 90
 Location ----- Rear of fuel meter assembly
 Element ----- Paper

INJECTION NOZZLES

Number ----- 8
 Material ----- Brass
 Location ----- On intake manifold above intake ports
 Fuel Orifice Size ----- .0118
 Insulation ----- Bakelite block

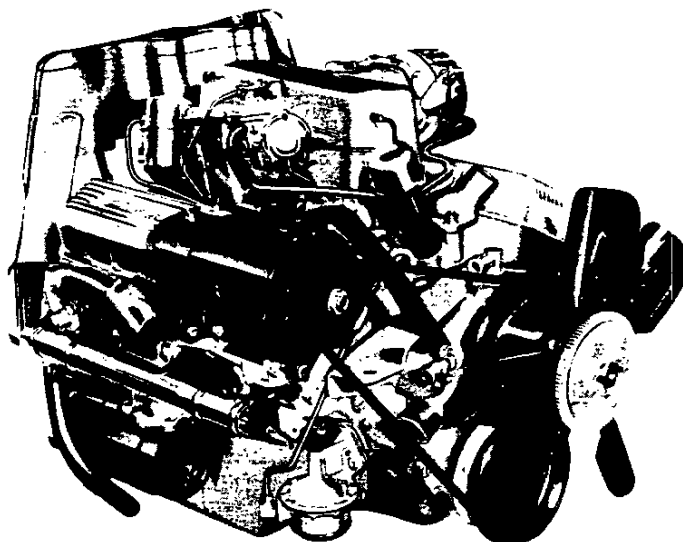

TRANSMISSIONS

3 AND 4-SPEED TRANSMISSIONS

Same basic structure as Passenger Car conventional 3 and 4-speed transmissions except all gearshift levers are floor-mounted.

The following transmission gear ratios are in effect:

3-Speed for all engines

First ----- 2.47:1
 Second ----- 1.53:1
 Third ----- 1:1
 Reverse ----- 2.80:1

4-Speed

ENGINE	250 HP	300 HP	340 HP	360 HP
First	2.54:1		2.20:1	
Second	1.89:1		1.64:1	
Third	1.51:1		1.31:1	
Fourth	1:1		1:1	
Reverse	2.61:1		2.26:1	

All 3-speed and 4-speed transmissions with a 3.36:1 rear axle ratio have a speedometer driven gear with 20 teeth; 4-speeds with a 3.70:1 rear axle ratio have 21 teeth.

AUTOMATIC TRANSMISSIONS

Same as passenger car Powerglide for 300 HP engine except for the following differences.

COOLING ----- Not required

SELECTOR LEVER LOCATION ----- Floor mounted

ELECTRICAL

BULBS

Location			Require-ments	Trade No.	CP
Head Lamps	Outer	High Beam	2	4002	37.5W
		Low Beam			50W
	Inner	High Beam	2	4001	37.5W
Cigarette Lighter			1	53	1
Headlamp Beam Indicator			1		
Direction Signal Indicator			2	57	2
Fuel, Temperature Gages			1		
Oil Battery Gages			1		
Speedometer Head			2		
Tachometer Gage			1		

Location	Require-ments	Trade No.	CP
Radio	1	57X	2
Clock	1	67	4
License	1		
Courtesy (Instru. Panel)	1	90	6
Park. Brake Alarm	1	257	2
Park and Turn	2	1034	32
Spotlamp, Portable	1	4416	30W
Tail, Stop, Turn	4	1034	32

FUSES AND CIRCUIT BREAKER

Device or Circuit Protected	Fuse and Amp	Circuit Breaker	* Location
Cigarette Lighter Lamp Clock Lamp Fuel, Temperature Gages Lamp Oil, Battery Gages Lamp Parking Brake Alarm Radio Lamp Speedometer Head Lamps Tachometer Lamps	AGC 3		FB
Radio Receiver	AGC 7.5		
Heater	AGC 10		
Clock Motor Courtesy Lamp License Lamp Stop and Turn Lamps Tail Lamps	AGC 15		
Direction Signal Indicator		Flasher	
Headlamps Headlamp Beam Indicator Park and Turn		15 Amp	Light Switch
Hydraulic Folding Top Motor Power Windows		40 Amp	EC
W/S Wiper 2-Speed Motor		Thermal Overload	Motor

* FB = Fuse Block; EC = Engine Compartment.

AMA Specifications – Passenger Car

The information contained herein is prepared, distributed by, and is solely the responsibility of the automobile manufacturing company to whose products it relates. Questions concerning these specifications should be directed to the manufacturer whose address is shown below. This uniform specification form was developed by the automobile manufacturing companies under the auspices of the Automobile Manufacturers Association.

52

MANUFACTURER Chevrolet Motor Division General Motors Corporation	CAR NAME <p style="text-align: center; font-weight: bold;">CORVETTE</p>		
MAILING ADDRESS Chevrolet Engineering Center Box 7346, N. End Station Detroit 2, Michigan	<table border="1" style="width: 100%; border-collapse: collapse;"> <tr> <td style="width: 60%; padding: 5px;"> MODEL YEAR <p style="text-align: center;">1962</p> </td> <td style="width: 40%; padding: 5px;"> ISSUED: 10-23-61 REVISED (e) </td> </tr> </table>	MODEL YEAR <p style="text-align: center;">1962</p>	ISSUED: 10-23-61 REVISED (e)
MODEL YEAR <p style="text-align: center;">1962</p>	ISSUED: 10-23-61 REVISED (e)		

NOTES:

1. The Specifications herein are those in effect at date of compilation and are subject to change without notice by the manufacturer.
2. UNLESS OTHERWISE INDICATED:
 - a. Specifications apply to the standard model without optional equipment. Significant deviations are noted.
 - b. Specifications apply basically to 4-door sedan or equivalent.
 - c. Nominal design dimensions are used throughout these specifications.

TABLE OF CONTENTS

General Specifications 1	Drive Units 13	Rear Suspension 19	Body & Car - General 26
Engine - Mechanical 2	Brakes 16	Body Dimensions 20	Weights 27
Electrical 8	Front Suspension & Steering . . 17	Station Wagon 25	Index 28

BODY—TYPES AND STYLE NAMES—

Body type, number of passenger & style names; use manufacturer's code for series & body style.

Model 867 2-door convertible, 2-passenger

AMA Specifications – Passenger Car

MAKE OF CAR CHEVROLET MODEL YEAR 1962 DATE ISSUED 10-23-61 REVISED ^(*) 12-1-61

GENERAL SPECIFICATIONS

(All dimensions in inches unless otherwise indicated)

MODEL CORVETTE	Additional Information Page No.:		
Wheelbase (L-101)	23	102.0	
Track	Front (W-101)	57.0	
	Rear (W-102)	59.0	
Maximum Overall Dimensions	Length (L-103)	176.7	
	Width (W-103)	70.4	
	Height (H-101)	52.2 (Hardtop 52.1)	
Transmission— (Specify trade name - opt., not available)	Manual	3-speed Synchronesh; 4-speed optional	
	Overdrive	None	
	Automatic	Powerglide (optional)	
Con-ventional axle ratio	Manual	3-speed 3.36:1; *4-speed 3.36:1 (optional 3.08:1)	
	Overdrive	None	
	Automatic	3.36:1	
Tire size	16	6.70 x 15-4 ply	
Engine	Type, no. cyl., valve arr.	4 Engines available 90° V-8, OHV	
	Fuel system (Carb., other)	Carburetor (b)	
	Bore and stroke	4.00 x 3.25	
	Piston displ., cu.in.	327.0	
	Std. compression ratio	10.5:1 @	
	Max. bhp at engine rpm (Gross)	2	(1) 250 hp at 4400 rpm (2) 300 hp at 5000 rpm (3) 340 hp at 6000 rpm (4) 360 hp at 6000 rpm
	Max. torque at rpm lb-ft (Gross)	2	(1) 250 hp - 950 at 2800 rpm (2) 300 hp - 360 at 3200 rpm (3) 340 hp - 344 at 4000 rpm (4) 360 hp - 352 at 4000 rpm

* - For 250 and 300 hp engines; for 340 and 360 hp engines, 4-speed ratio is 3.70:1. Form Rev. 6-60

(b) - Fuel injection for 360 hp engine.

@ - 11.25:1 for 340 and 360 hp engines.

AMA Specifications—Passenger Car

Page 2

MAKE OF CAR CHEVROLET MODEL YEAR 1962 DATE ISSUED 10-23-61 REVISED ^(a) 3-1-62

MODEL <u>CORVETTE</u>	250 hp	300 hp	340 hp	360 hp
-----------------------	--------	--------	--------	--------

ENGINE—GENERAL

Type, no. cyls., valve arr.		90° V-8 OHV		
Bore and stroke (nominal)		4.00 x 3.25		
Piston displacement, cu. in.		327.0		
Bore spacing (C/L to C/L)		4.40		
Valve system front to rear	L. Bank	1-3-5-7		
	R. Bank	2-4-6-8		
Firing order		1-8-4-3-6-5-7-2		
Compres. ratio (nominal)		10.5:1	11.25:1	
Cylinder Head Material		High chrome cast alloy iron		
Cylinder Sleeve—Wet, dry, none		None		
Number of mounting points	Front	Two		
	Rear	One		
Engine Installation angle		+ 1°		
Axle Dia. ² x No. Cyl. Borepower ^{2.5}		51.2		
Developed max. bhp* eng. RPM		250 @ 4400	300 @ 5000	340 @ 6000
Developed max. torque* ft. @ RPM		350 @ 2800	360 @ 3200	344 @ 4000
Recommended fuel angular premium		Premium		
Idle speed (spec. neutral or drive)	Manual 3 & 4	500 rpm (neutral)		700 rpm (neutral)
	Automatic	475 rpm (drive)		-----

ENGINE—PISTONS

Material		Cast aluminum alloy		
Description and finish		(a)		
Weight (piston only) oz.		21.34 (with strut) •	19.82 •	

Max. bhp (brake horsepower) and max. torque corrected as defined by SAE Engine Test Code.

(Continued)

Form Rev. 6-60

a) - For 250 and 300 hp engines, flat head slipper skirt autothermic having machined relief for valve clearance. For 340 and 360 hp engines, impact extruded aluminum, domed pistons are used.

AMA Specifications – Passenger Car

MAKE OF CAR CHEVROLET MODEL YEAR 1962 DATE ISSUED 10-23-61 REVISED (*)

POWER TEAMS

(Indicate whether standard or optional)

MODEL AVAILABILITY	ENGINE					TRANSMISSION	AXLE RATIO (Std. first)	
	Displ. cu. in.	Carburetor	Compr. Ratio	BPH @ RPM	Torque @ RPM		Axle	
				(Gross)	lb-ft (Gross)		Conventional	Positraction
Corvette 867								
Engine	327	4-Bbl	10.5:1	250	350	3-Speed	3.36:1	3.36:1
Standard				@ 4400	@ 2800	4-Speed † (b)	3.36:1*	3.08:1, 3.36:1
						Powerglide ‡	3.36:1	3.36:1
Optional	327	Large 4-Bbl	10.5:1	300	360	3-Speed	3.36:1	3.36:1
				@ 5000	@ 3200	4-Speed † (b)	3.36:1*	3.08:1, 3.36:1
						Powerglide ‡	3.36:1	3.36:1
Optional	327	Large 4-Bbl	11.25:1	340	344	3-Speed	3.36:1	3.36:1
				@ 6000	@ 4000	4-Speed † (b)	3.70:1	3.08:1 3.36:1 3.55:1 3.70:1 4.11:1 4.56:1
Optional	327	Fuel Inj.	11.25:1	360	352	3-Speed	3.36:1	3.36:1
				@ 6000	@ 4000	4-Speed † (b)	3.70:1	3.08:1 3.36:1 3.55:1 3.70:1 4.11:1 4.56:1

* - Optional 3.08:1 available.
 † - Optional
 @ - Other ratios available are 4.88:1, 5.14:1 and 5.43:1
 (b) - Two available optionally

AMA Specifications – Passenger Car

MAKE OF CAR CHEVROLET MODEL YEAR 1962 DATE ISSUED 10-23-61 REVISED 12-1-61

MODEL <u>CORVETTE</u>	250 hp	300 hp	340 hp	360 hp
-----------------------	--------	--------	--------	--------

ENGINE PISTONS (Cont.)

Clearance (limits)	Top land	.0032-.0068	.0031-.0065
	Skirt		
Ring groove depth	No. 1 ring	.0006-.0010	.2268-.2288
	No. 2 ring		.2268-.2288
	No. 3 ring		.2038-.2103
	No. 4 ring		None

ENGINE-RINGS

Function (top to bottom)	No. 1, oil or comp.		Compression
	No. 2, oil or comp.		Compression
	No. 3, oil or comp.		Oil
	No. 4, oil or comp.		None
Compression	Description - material, type, coating, etc.	Inside bevel, cast alloy iron, chrome plated OD	
	Width	Upper .0775-.0780; Lower .0770-.0775	
	Gap	.0013-.0025	
Oil	Description - material, type, coating, etc.	Multi-piece (2 rails and one spacer expander) Rails - steel, chrome plated OD Spacer - stainless steel	
	Width	.184-.189	
	Gap	.015-.055	
Expanders		In oil ring assembly	

ENGINE-PISTON PINS

Material	Chrome steel		
Length	2.990-3.010		
Diameter	.9270-.9273		
Type	Locked in rod, in piston, floating, etc.	Locked in rod	
	Bushing	In rod or piston	None
		Material	-----
Clearance	In piston	.00015-.00025	
	In rod	None	
Direction & amount offset in piston		Major thrust side - .055-.065	Pin on center

ENGINE-CONNECTING RODS

Material	Drop forged steel		
Weight (oz.)	20.32		
Length (center to center)	5.699-5.701		
Bearing	Material & Type	Premium aluminum, removable	
	Overall length	.817	
	Clearance (limits)	Vertical .0007-.0028; Horizontal .0017-.0038	
	End play	.008-.014	

AMA Specifications—Passenger Car

Page 4

MAKE OF CAR CHEVROLET MODEL YEAR 1962 DATE ISSUED 10-23-61 REVISED _____

MODEL CORVETTE 250 hp 300 hp 340 hp 360 hp

ENGINE—CRANKSHAFT

Material		Forged steel	
Vibration damper type		Inertia, rubber mounted	
End thrust taken by bearing (No.)		5	
Crankshaft end play		.002-.006 \bar{z}	
Main bearing	Material & type	Premium aluminum, removable	
	Clearance	.0008-.0034	
	Journal dia. and bearing overall length	No. 1	2.2983 x .762
		No. 2	2.2983 x .762
		No. 3	2.2983 x .762
		No. 4	2.2983 x .762
		No. 5	2.2983 x 1.169
No. 6	None		
No. 7	None		
Dir. & amt. cyl. offset		None	
Crankpin journal diameter		1.999-2.000	

ENGINE—CAMSHAFT

Location		Above crankshaft	
Material		Cast alloy iron	
Bearings	Material	Extra-life steel backed babbitt	
	Number	5	
Gear or chain		Chain	
Crankshaft gear or sprocket material		Steel	
Type of Drive	Camshaft gear or sprocket material		Cast alloy iron
	Timing chain	No. of links	46
		Width	.875
		Pitch	.500

ENGINE—VALVE SYSTEM

Hydraulic lifters (Std, opt, NA)		Hydraulic	Hydraulic	Mechanical	Mechanical
Valve rotator, type (intake, exhaust)		None			
Rocker ratio		1-1/2:1			
Operating tappet clearance (indicate hot or cold)	Intake	---		.008 (hot)	
	Exhaust	---		.018 (hot)	
Timing marks on flywheel, damper, other		Damper			

(Continued)

Rev. Form 3-59

AMA Specifications—Passenger Car

MAKE OF CAR CHEVROLET MODEL YEAR 1962 DATE ISSUED 10-23-61 REVISED 12-1-61

MODEL <u>Corvette</u>	250 HP	300 HP	340 HP	360 HP
-----------------------	--------	--------	--------	--------

ENGINE—VALVE SYSTEM (cont.)

Timing *	Intake	Opens (°BTC)	32° 30'	35° †	
		Closes (°ABC)	87° 30'	72° †	
		Duration - deg.	300°	287° †	
	Exhaust	Opens (°BBC)	74° 30'	76° †	
		Closes (°ATC)	45° 30'	31° †	
		Duration - deg.	300°	287° †	
	Valve opening overlap		78° ●	66° †	
Material		Carbon Steel			
Intake	Overall length		4.902-4.922	4.870-4.889	
	Actual overall head dia.		1-23/32	1-15/16	
	Angle of seat & face		46° & 45°		
	Seat insert material		None		
	Stem diameter		.3410-.3417		
	Stem to guide clearance		.001-.0027		
	Lift		.3987 (Theoretical)	.3938 (Theoretical) ●	
	Outer spring press. and length	Valve closed (lb. @ in.)	65-80 @ 1-45/64		
		Valve open (lb. @ in.)	155-170 @ 1-5/16		
	Inner spring press. and length	Valve closed (lb. @ in.)	Valve Spring Damper 5-10 lb		
Valve open (lb. @ in.)					
Material		Armco Valve Steel (aluminized faces)			
Exhaust	Overall length		4.913-4.933	4.891-4.910	
	Actual overall head dia.		1-1/2		
	Angle of seat & face		46° and 45°		
	Seat insert material		None		
	Stem diameter		.3410-.3417		
	Stem to guide clearance		.001-.0027		
	Lift		.3987 (Theoretical)	.3998 (Theoretical) ●	
	Outer spring press. and length	Valve closed (lb. @ in.)	Same as Intake		
		Valve open (lb. @ in.)	Same as Intake		
	Inner spring press. and length	Valve closed (lb. @ in.)	Same as Intake.		
Valve open (lb. @ in.)					

ENGINE—LUBRICATION SYSTEM

Type of lubrication (splash, pressure, nozzle)	Main bearings	Pressure
	Connecting rods	Pressure
	Piston pins	Splash
	Camshaft bearings	Pressure
	Tappets	Pressure
	Timing gear or chain	Nozzle Spray
	Cylinder walls	Pressure, Jet Cross Spray

* - Including cam ramps.

† - With .012 intake lash and .018 exhaust lash.

(Continued)

Rev. Form 3-59

AMA Specifications - Passenger Car

Page 6

MA OF CAR CHEVROLET **MODEL YEAR** 1962 **DATE ISSUED** 10-23-61 **REVISED** ⁽⁶⁾ 3-1-62
MODEL Corvette 250 HP 300 HP 340 HP 360 HP

ENGINE-LUBRICATION SYSTEM (cont.)

Oil pump type	Gear
Normal oil pressure (lb. @ engine rpm)	45 @ 2000
Oil pressure sending unit (elect. or mech.)	Electric
Type oil intake (floating, stationary)	Stationary
Oil filter system (full flow, partial, other)	Full flow
Filter replacement (element, complete)	Element
Capacity of crankcase, less filter-refill (qt.)	5.0
Oil grade recommended (SAE viscosity and temperature range)	32°F & above - SAE 20W, SAE 20, SAE 10W-30 0°F & above - SAE 10W, SAE 10W-30 Below 0°F - SAE 5W, SAE 5W-20 Sustained High Speed over 90°F - SAE 30 can be used
Engine Service Requirement (MM, MS, etc.)	MS or DG

ENGINE-EXHAUST SYSTEM

Type (single, single with cross-over, dual, other)	Dual	Dual with cross-over
Muffler No. & type (reverse flow, straight thru, separate resonator)	Two, reverse flow	
Exhaust pipe dia. (O.D. & wall thickness)	Branch	None
	Main	2 x 1/16
Exhaust manifold diameter (O.D. & wall thickness)	1-7/8 x 1/16	

ENGINE-FUEL SYSTEM

(See Supplement to Page 6 for Details of Fuel Injection, Supercharger, etc. if used)

Induction type: Carburetor, fuel injection, supercharger.	Carburetor	Fuel Injection
Fuel Tank	16.4 (c)	
Capacity (gals.)	Rear of left door opening	
Filler location	Mechanical	
Fuel Pump	Lower right front corner of engine	
Type (elec. or mech.)	5.25-6.50	
Locations	None	
Pressure range	None	
Vacuum booster (std., optional, none)	None	
Fuel Filter (a)	Type	Sintered bronze (b)
	Locations	Carburetor inlet (b)
Carburetor	Make & Model No.	Carter 3788246 Carter 3797699
	Number of carbs., bbls. per carb. & type	One, 4-barrel, downdraft
	Barrel size	SAE Carb. size (throttle body) - 1.50
	Choke type	Automatic
	Intake manifold heat control (exhaust or water)	Exhaust
	Air circ. type	Oil wetted, polyurethane
	Optional	None

- a) Additional plastic mesh filter in fuel tank
- b) Fuel filter with paper element between fuel pump and carburetor.
- c) 24 gallon tank available as option (RPO 488)

Rev. Form 3-59

AMA Specifications -- Passenger Car

Supplement to Page 6

MAKE OF CAR CHEVROLET MODEL YEAR 1962 DATE ISSUED 10-23-61 REVISED _____

SUPPLEMENTARY INFORMATION

Engine Fuel System - Fuel Injection

MODEL Corvette - 360 HP

Injection System	Make Model Type	Rochester Products 7017360 Constant flow
Fuel Recommended		Premium
Fuel Pump	Type Location Pressure range	Mechanical Lower right front corner of engine 5.25-6.50 psi
Auxiliary Fuel Filter	Type Location	Paper filter Bracket to engine adapter on right, rear of center
Inlet Manifold Adapter - Material		Cast aluminum
Inlet Manifold - Material		Cast aluminum
Air Induction (a)	Air cleaner type Air meter location Plenum chamber Ram pipes Ram pipe length	Oil-wetted, polyurethane Left side of engine Integral with inlet manifold Eight, integral with inlet manifold 12 inches
Fuel Induction		Metered as function of air flow
Air/Fuel Ratio Control	Type Location	Vacuum sensitive diaphragm On fuel meter & choke butterfly valve in air meter
Fuel Meter Pump	Type Location Drive Pressure (max.)	Gear In fuel meter assembly Flexible shaft from distributor 300 psi
Injection Nozzles	Number used Material Location Orifice size, fuel Insulation	Eight Brass Mounted on inlet manifold above inlet ports .0118 Bakelite blocks
Automatic Enrichment	Type Location Current draw Fast idle cam	Electric, time-temperature On air meter assembly 1 amp @ 70° Yes

(a) - Air intake ducts which channel outside air to engine compartment are furnished with Fuel Injection.

AMA Specifications – Passenger Car

MAKE OF CAR CHEVROLET MODEL YEAR 1962 DATE ISSUED 10-23-61 REVISED 3-1-62

MODEL Corvette

ENGINE--COOLING SYSTEM

Type system (pressure, pressure vented, atmospheric, other)		Pressure	
Radiator cap relief valve pressure		13 psi ± 1 psi	
Circulation thermostat	Type (choke, bypass)	Bypass	
	Starts to open at (°F)	167-172	
Water pump	Type (centrifugal, other)	Centrifugal	
	Number of pumps	One	
	Drive (V-belt, other)	V-belt	
	Bearing type	Double row ball	
By-pass recirculation type (internal, external)		Internal	
Radiator core type (cellular, tube and fin, other)		Aluminum - cross flow	
Cooling system capacity	With heater (qt.)	16.5 ●	
	Without heater (qt.)	15.5 ●	
	Opt. equipment-specify (qt.)	None	
Water jackets full length of cylinder (yes, no)		Yes	
Water all around cylinder (yes, no)		Yes	
Radiator hose	Lower	Number and type (molded, straight)	One, molded
		Inside diameter	1.75
	Upper	Number and type (molded, straight)	One, molded
		Inside diameter	1.50
	By-pass	Number and type (molded, straight)	None
		Inside diameter	---
Fan	Number of blades & Spacing		5-blade
	Diameter		17.12
	Ratio-fan to crankshaft rev.		1.05
	Fan cutout type		Thermo-modulated fluid coupling
	Bearing type		Double row ball
*Drive belts (Indicate belt used by letter)	Fan		A and B ●
	Generator		A
	Water Pump		A and B ●
	Power Steering		None
	Air Conditioning		None

Rev. Form 3-59

* Drive Belt Dimensions	A	B @ ●	
Angle of V	37-44°	39° - 41°	
Nominal length (SAE)	56.0	38.0	
Width	.380 ± .005	.380 ± .005	

@ 340 and 360 HP engines have additional belt with idler pulley for water pump and fan. ●

AMA Specifications - Passenger Car

MAKE OF CAR CHEVROLET **MODEL YEAR** 1962 **DATE ISSUED** 10-23-61 **REVISED** 12-1-61
MODEL Corvette 250 HP 300 HP 340 HP 360 HP

ELECTRICAL—SUPPLY SYSTEM

Battery	Make and Model	Delco, 1980558			
	Voltage Rtg. & Total Plates	12 Volt, 11 plate per cell			
	SAE Designation & Amp Hr. Rtg.	2 SND, 61 amp. hr @ 20 hr. rate			
	Location	Right side of Engine Compt. on frame			
	Terminal grounded	Negative			
Generator	Make	Delco			
	Model	1102174	1102268		
	Type	Two brush, shunt wound			
	Ratio—Gen. to Cr/s rev.	1.84	1.66		
	Gen. cut-in (hot)—engine rpm	650			
Regulator	Make	Delco			
	Model	1119002			
	Type	Vibrator			
	Cutout relay	Closing voltage @ generator rpm	11.8-13.5 @ 1300		
		Reverse current to open			
	Regulated	Voltage	13.8-14.8		
		Current	33-37.		
	Voltage test conditions	Temperature	Operating		
Load		10 amps. max			
Other		None			

ELECTRICAL—STARTING SYSTEM

Starting motor	Make	Delco			
	Model	1107233			
	Rotation (drive end view)	Clockwise			
	Engine cranking speed	-----			
	Test conditions	Engine at operating temperature			
	Lock test	Amps	435		
		Volts	5.8		
		Torque (lb. ft.)	10.5 lb-ft min		
	No load test	Amps	65 min, 100 max		
		Volts	10.6		
RPM (min.)		3600 min, 5100 max			
Motor control	Switch (solenoid, manual)	Solenoid			
	Starting procedure	3 & 4-Speed - Depress clutch and shift into natural; Powerglide - Put selector in "P" or "N", depress accelerator pedal to floorboard to set automatic choke, turn ignition to extreme right to engage starting motor.			

AMA Specifications – Passenger Car

MAKE OF CAR CHEVROLET MODEL YEAR 1962 DATE ISSUED 10-23-61 REVISED 12-1-61
 MODEL Corvette 250 HP 300 HP 340 HP 360 HP

ELECTRICAL—STARTING SYSTEM (cont.)

Motor Drive	Engagement type		Positive shift solenoid	
	Pinion meshes (front, rear)		Rear	
	Number of teeth	Pinion	9	
		Flywheel	168	
Flywheel tooth face width		.4135		

ELECTRICAL—IGNITION SYSTEM

Coil	Make		Delco	
	Model		1115091	1115107
	Amps	Engine stopped	4.0	
Engine idling		1.8		
Distributor	Make		Delco	
	Model		1110984	1110985 1111011 ●
	Cent'fgal adv. in crankshaft degrees @ engine rpm (nominal)	Start (rpm)	700	
		Intermediate points deg. @ rpm	11° @ 1600	
		Max deg. @ rpm	24° @ 4600	
	Vacuum adv. in crankshaft degrees @ in. Hg. (nominal)	Start (in Hg)	8	None
		Intermediate points, deg @ in Hg	-----	-----
		Max. deg. in. Hg.	15° @ 15.5	-----
	Breaker gap (in.)		.016-.019	
	Cam angle (deg.)		30°	29° per breaker; 34° total
Breaker arm tension (oz.)		19-23		
Timing	Crankshaft deg. @ rpm.		8° BTC @ 500	10° BTC @ 700
	Mark location		Damper	
	Cylinder numbering system (see page 2)			
Firing order (see page 2)				
Spark Plug	Make and model		AC 44 ●	
	Thread (mm)		14	
	Tightening torque (lb. ft.)		25	
	Gap		.033-.038	
Cable	Conductor type		Liner core impregnated with electrical conducting material	
	Insulation type		Rubber with Neoprene jacket	
	Spark plug protector		Hypalon jacket	

ELECTRICAL—SUPPRESSION

Locations & type	Non-metallic high tension cable
------------------	---------------------------------

AMA Specifications – Passenger Car

MAKE OF CAR CHEVROLET MODEL YEAR 1962 DATE: ISSUED 10-23-61 REVISED 12-1-61

M. L. Corvette

ELECTRICAL—INSTRUMENTS AND SWITCHES

Speed-ometer	Make	AC
	Trip odometer (yes, no)	No
Charge indicator—type		Ammeter
Temperature indicator—type		Gauge (electric)
Oil pressure indicator—type		Gauge (bourden tube)
Fuel indicator—type		Gauge (electric)
Other		Tachometer (mechanical)
Ignition switch	Identify positions in order and circuits controlled	Counterclockwise from vertical ----- Off, lock
		Vertical ----- Off, unlocked
		1st pos. clockwise from vertical ----- On, ing & accessories
2nd pos. clockwise from vertical ----- Start, ign & starter spring return to On		
	Provision for illumination	None
	Location	On instrument panel, right of steering column
Main lighting switch	Identify positions and lamps controlled	Depressed - off
		1st notch - instrument panel, parking, tail, license lamps 2nd notch - instrument panel, head, tail, license lamps Rotate clockwise to dim or turn off instrument panel lamps, counterclockwise to turn on or brighten panel lamps and light ● courtesy lamp.
Other light switches	Locations and lamps controlled	Toe panel ----- Headlamp dimmer
		Steering column ----- Turn signal
		Hinge pillars ----- Courtesy lamps (b) ●
		Brace below instrument panel -- Stop lamps
	Parking brake handle shaft ---- Parking brake alarm lamp ●	
Other switches	Locations and devices controlled	Instrument panel, center ----- Power folding top (a)
		Instrument panel, left ----- Electric windshield wipers
		Door panels, LH and RH ----- Electric window lifts (a)
		Instrument panel, lower ----- Radio (a)
		Instrument panel, lower ----- Heater blower ●
Windshield wiper	Make	Delco
	Type	Electric, 2-speed
	Vacuum booster provision	None
	Washer provision	Standard Equipment (includes co-ordinator & vacuum reserve tank)
Horn	Type	Vibrator
	Number used	2
	Amp draw (each)	8.0-11.0 @ 12.5 volts

(a) - Available optionally.

● (b) - Also mainlight switch.

AMA Specifications – Passenger Car

MAKE OF CAR CHEVROLET MODEL YEAR 1962 DATE ISSUED 10-23-61 REVISED _____
 MODEL Corvette

ELECTRICAL—LAMP BULBS

Give quantity used and trade number, e.g., Headlamp 2-5400 S, dual headlight 2-4001, 2-4002.
 Indicate accessories which are not standard equipment by an asterisk following the numbers.

Headlamps & arrangement		Dual headlight 2-4001, 2-4002
Headlamp beam indicator		1-53
Parking		2-1034 (4 cp filaments)
Tail		4-1034 (4 cp filaments)
Stop		4-32 cp filaments of tail lamp bulbs
Direction signal	Front	2-32 cp filaments of parking lamp bulbs
	Rear	4-32 cp filaments of tail lamp bulbs
	Indicator	2-57
License plate		1-67
Instrument (Speedo.)		2-57
Ignition lock		N. A.
Back up		N. A.
Dome		----
Clock		1-67
Radio		1-57X *
Glove compartment		----
Park brake alarm		1-257
Courtesy light		1-90
Cig. lighter light		1-53
Fuel & temp. gauges		1-57
Oil & Batt. gauges		1-57
Tachometer		1-57
Spot Lamp (Portable)		1-4416 *

AMA Specifications - Passenger Car

MAKE OF CAR CHEVROLET MODEL YEAR 1962 DATE: ISSUED 10-23-61 REVISED _____

MODEL Corvette

ELECTRICAL—FUSE & CIRCUIT BREAKER DATA

Use trade number of fuse, e.g., SFE-10. Indicate circuit breaker by ampere capacity suffixed by letters "C.B.", e.g., 30 C.B. Where fuse or circuit breaker protects multiple circuits indicate first use by a letter and repeat the same letter for all units protected by the same fuse or circuit breaker, e.g., Parking lamp SFE-10 (a), Direction indicator same as (a).

Headlamp	15 CB (a)
Headlamp beam indicator	(a)
Parking lamp	(a)
Tail lamp	AGC 15 (b)
Stop lamp (& Dir. Sig.)	(b)
Direction indicator	Flasher
License plate lamp	(b)
Instrument lamp	AGC 3 (c)
Ignition lamp	N. A.
Back up lamp	N. A.
Dome lamp	----
Clock	(b)
Clock lamp	(c)
Radio	Light (c); Receiver AGC 7.5 (d)
Glove compartment lamp	----
Park brake alarm (flshg)	(c)
Power windows	40 CB (g)
Heater blower	AGC 10 (e)
Cig. lighter lamp	(c)
Power top	40 CB (f)
Co esy Lamp	(b)
Fuel & Temp Gages Lamp	(c)
Oil & Battery Gages Lamp	(c)
Tachometer Lamp	(c)

ELECTRICAL—LOCATION OF OUTSIDE LAMPS

	Tail	Lowest	21.9	
		Highest	21.9	
Height above ground to center of bulb	Stop		21.9	
	Backup		None	
	License, rear		21.2	
	Directional	Front		13.0
		Rear		21.9
	Headlamp	Inside		28.4
		Outside*		28.4
	Distance from C/L of car to center of bulb	Tail	Inside	19.00
			Outside	25.00
		Stop		19.00 inside; 25.00 outside
Backup			None	
License, rear			.38 to left	
Directional		Front		19.2
		Rear		19.00 inside; 25.00 outside
Headlamp		Inside		22.8
		Outside*		29.1

* If 1 headlamps are used enter here.

AMA Specifications – Passenger Car

MAKE OF CAR CHEVROLET MODEL YEAR 1962 DATE ISSUED 10-23-61 REVISED (a)
 MODEL Corvette

DRIVE UNITS—CLUTCH (Manual Transmission)

Make & type	Borg and Beck, dry plate, semi-centrifugal		
Type pressure plate springs	Coil		
Effective plate pressure (lb.)	2000-2300		
No. of clutch driven discs	One		
Clutch facing	Material	Premium woven asbestos composition	
	Outside & inside dia.	10.0 x 6.5	
	Total eff. area (sq.in.)	90.68	
	Thickness	.135	
	Engagement cushioning method	Springs	
Release bearing	Type & method of lubrication	Ball bearing, sealed	
Torsional damping	Methods: springs, friction material	None	

DRIVE UNITS—TRANSMISSIONS

Manual (std. or opt.)	3-Speed Standard; 4-Speed Optional		
Manual with overdrive (std. or opt.)	N, A.		
Automatic (std. or opt.)	Optional for 250 and 300 HP engines only		

DRIVE UNITS—MANUAL TRANSMISSION

Number of forward speeds		Three	Four *	
Transmission ratios	In first	2.47:1	2.20:1	
	In second	1.53:1	1.66:1	
	In third	1.00:1	1.31:1	
	In fourth	-----	1.00:1	
	In reverse	2.80:1	2.26:1	
Synchronous meshing, specify gears		2nd and 3 rd	All forward gears	
Shift lever location		Floor	Floor	
Lubricant	Capacity (pt.)	2.0	2.5	
	Type recommended	Multi-purpose gear lubricant		
	SAE viscosity number	Summer	SAE 90	
		Winter	SAE 90	
Extreme cold		SAE 80		

* - Available optionally. first 2.54:1, second 1.92:1, third 1.51:1, fourth 1:1, reverse 2.61:1

AMA Specifications – Passenger Car

MAKE OF CAR CHEVROLET MODEL YEAR 1962 DATE ISSUED 10-23-61 REVISED _____
 MODEL Corvette

DRIVE UNITS—MANUAL TRANSMISSION WITH OVERDRIVE

transmission data see manual transmission section

Overdrive	Type (planetary or other)		Not Available	
	Manual lockout (yes, no)		--	
	Downshift accelerator control (yes, no)		--	
	Minimum cut-in speed		--	
	Gear ratio		--	
	Lubricant	Capacity (pt.) (Overdrive only)		--
		Separate filler (yes, no)		--
		Type recommended		--
		SAE viscosity number	Summer	--
			Winter	--
Ext. cold		--		

DRIVE UNITS—AUTOMATIC TRANSMISSION

Trade name	Powerglide	
How describe	Torque converter with planetary gears	
Method of Selection (Lever, Push Button or other)	Lever	
Selector Pattern	P-R-N-D-L	
Number of gears (a) Selector Pattern and indicate which are used in each selector position	(a) Drive 1.76:1 & 1:1 Low & Reverse 1.76:1	
Max. upshift speeds—drive range	65	
Max. kickdown speeds—drive range	62	
Torque converter	Number of elements	3
	Max. ratio at stall	2.10:1
	Type of cooling (air, water)	None
Lubricant	Capacity—refill (pt.)	3
	Type recommended	A, Suffix A
Special transmission features	Three element hydraulic torque converter with automatic planetary gear system for reverse and low	

Rev. Form 3-59

(a) - Total transmission torque multiplication - 3.70:1

AMA Specifications – Passenger Car

MAKE OF CAR CHEVROLET MODEL YEAR 1962 DATE ISSUED 10-23-61 REVISED (*)

MODEL Corvette

DRIVE UNITS—PROPELLER SHAFT

Number used		One
Type (exposed, torque tube)		Exposed
Outer diameter x length* x wall thickness	Manual transmission	2.5 x 34.55 x .065
	Overdrive transmission	N. A.
	Automatic transmission	2.5 x 34.55 x .065
Inter-mediate bearing	Type (plain, anti-friction)	None
	Lubrication (fitting, prepack)	None
Universal joints	Make	Chevrolet
	Number used	Two
	Type (ball and trunnion, cross, other)	Yoke and spider (trunnion)
	Bearing	Type (plain, anti-friction)
Lubric. (fitting, prepack)		Fitting
Drive taken through (torque tube or arms, springs)		Rear springs and radius rods
Torque taken through (torque tube or arms, springs)		Rear springs and radius rods

DRIVE UNITS—REAR AXLE

Description - (incl. limited slip differential)		Standard axle, semi-floating, overhung pinion gear Positraction - semi-floating overhung pinion gear Spicer limited slip with dual 4-disk clutches applied by reaction torque through differential side gears	
Drive Pinion Offset		1.5	
No. of differential pinions		2(a)	
Standard Gear ratio and No. of teeth (b)	Manual transmission (3 & 4)	3.36:1 (11-37); 3.70:1 (10-37)	
	Overdrive transmission	N. A.	
	Automatic transmission	3.36:1 (11-37)	
Ring gear pitch diameter & O.D.		8.375 PD and OD	
Pinion adjustment (shim, other)		Shim	
Pinion bearing adj. (shim, other)		None	
Wheel bearing type		Ball	
Capacity (pt.)		4.0	
Lubricant	Type recommended	A-9 hypoid	
	SAE viscosity number	Summer	SAE - 90
		Winter	SAE - 90
		Extreme cold	SAE - 90

*Center to center of universal joints, or to centerline of rear attachment.

(a) - 4 pinions in positraction

(b) - See page 2A for positraction availability and optional conventional axle ratios.

AMA Specifications - Passenger Car

MAKE OF CAR CHEVROLET MODEL YEAR 1962 DATE ISSUED 10-23-61 REVISED (a) 3-1-62

MODEL: Corvette

DRIVE UNITS—WHEELS

Type & material		Short spoke disk, pressed steel
Size (size and flange type)		15 x 5K (a)
Attachment	Type (bolt or stud)	Stud
	Circle diameter	4.75
	Number and size	5, 7/16-20 UNF-2B

DRIVE UNITS—TIRES

Standard	Size & ply	6.70 x 15-4 ply (blackwall)(b)
Optional (sw)	Type - Nylon, etc.	Rayon (d)
Miles per gallon at 30 mph.		760
Position (cold)	Front	24
	Rear	24

BRAKES—SERVICE

Type (duo-servo, balanced, etc.)		Duo-Servo, 4 wheel hydraulic	
		Standard	Heavy-Duty, RPO 686(c)
Type (over brake make & type note, integral, etc.)		None	
Active area (sq. in.)*		157.0	134.0 ●
Lining area (sq. in.)**		157.0	134.0 ●
Opt drum area (sq. in.)***		259	327.0 ●
Percent brake effectiveness—front		58.5	58.5
Diameter	Front	11	
	Rear	11	
Type and material		Composite - cast alloy iron rim; pressed steel web	
Bonded or riveted		Bonded	Welded
Front Shoe	Material		Full molded asbestos comp
	Size (length x width x thickness)	Front wheel	9.34 x 2.0 x .168 ●
		Rear wheel	9.34 x 1.75 x .168 ●
	Segments per shoe		1
Rear Shoe	Material		Full molded asbestos comp
	Size (length x width x thickness)	Front wheel	11.75 x 2.0 x .164 ●
		Rear wheel	11.75 x 1.75 x .164 ●
	Segments per shoe		10
Wheel cylinder bore	Front	1.1875	
	Rear	1.00	
Master cylinder bore		1.00	
Available pedal travel		4.50	
Air pressure at 100 lb. pedal load		700 psi	
Clearance adjustment		Adjust to light drag, back off 12 notches	

Excludes rivet holes, grooves, chamfers, etc.

Includes rivet holes, grooves, chamfers, etc.

Total swept areas for four brakes

Widest lining contact width for each brake x its drum circumference.

Form Rev. 6-60

- a) - 15 x 15.5K wheels available as RPO
- b) - White wall tire available as RPO
- c) - Additional heavy-duty brakes included in chassis package RPO 687 (See Supplementary Information).
- d) - Nylon tires available optionally.

AMA Specifications -- Passenger Car

Supplement to Page 16

MAKE OF CAR CHEVROLET MODEL YEAR 1962 DATE ISSUED 10-23-61 REVISED (1) 3-1-62

SUPPLEMENTARY INFORMATION

MODEL Corvette

Optional Heavy Duty Brakes (RPO 687)*

Type		Duo-Servo, 4-wheel hydraulic	
Effective area (sq. in.)		126.0 •	
Gross lining area (sq. in.)		126.0 •	
Brake effectiveness, front		62%	
Drum	Diameter	Front	11
		Rear	11
Type & material		Composite; cast alloy iron rim pressed steel web	
Brake cooling at each wheel		Vanas cast on drum rim, air scoop on backing plate, fans between drum and wheel hub.	
Front Shoe Brake Lining	Attachment		Welded
	Material		Sintered iron
	Size	Front wheel	1.64 x 1.25 x .205 •
		Rear wheel	2.00 x .875 x .205 •
Segments per shoe		6	
Rear Shoe Brake Lining	Attachment		Welded
	Material		Sintered iron
	Size	Front wheel	1.64 x 1.25 x .325 •
		Rear wheel	2.0 x .875 x .325 •
Segments per shoe		Front: 12; Rear: 10	
Wheel cyl. bore	Front	1.125	
	Rear	0.875	
Master cylinder bore		1.0	
Available pedal travel		4.5	
Line pressure @ 100 lb pedal load		700 psi	
Shoe clearance adjustment		Adjust to slight drag, back off 17 notches	

* - RPO 687 includes fast steering adapter and Heavy-Duty shock absorbers.

AMA Specifications—Passenger Car

MAKE OF CAR CHEVROLET MODEL YEAR 1962 DATE ISSUED 10-23-61 REVISED _____

MODEL Corvette

BRAKES—PARKING

Type of control		T-handle pull rod
Location of control		Below instrument panel, left of steering column
Operates on		Rear service brakes
If separate from service brakes	Type (internal or external)	None
	Drum diameter	None
	Lining size (length x width x thickness)	None

FRAME or UNITIZED CONSTRUCTION

Type and description	Full length welded box section side members, I-beam X-member. Bracing X-member to front side members. U-type rear shock absorber corssmember. Box section front and rear crossmember
----------------------	--

SUSPENSION—GENERAL (See Supplemental page 17 for details on Air Suspension)*

Provision for car leveling		None
Provision for brake dip control		None
Provision for acc. squat control		None
Special provisions for car jacking		Scissors type jack provided
Shock absorber front & rear	Type	Direct double acting (a)
	Make	Delco
	Piston dia.	1.0
Other special features		Auxiliary rear radius rods control spring wind-up

SUSPENSION—FRONT

Type and description	Unitized, independent, short and long arm
----------------------	---

(Continued)

Rev. Form 3-59

(a) - Each contains nitrogen-filled envelope in fluid reservoir to prevent fluid aeration.

* Air Suspension:
 Air spring type
 Compressor data
 type
 make
 drive ratio
 Normal operating pressures
 spring rates
 leveling data

AMA Specifications - Passenger Cars

MAKE OF CAR CHEVROLET MODEL YEAR 1962 DATE ISSUED 10-23-61 REVISED ⁽⁰⁾ 3-1-62

MODEL Corvette

5. SUSPENSION FRONT (cont.)

Spring	Type	Coil	
	Material	Chrome alloy steel	
	Size (coil design height & I.D.; bar length x dia.)	9.62 x 3.162 x 116.0 x .550	
	Spring rate (lb. per in.)	300	
	Rate at wheel (lb. per in.)	115	
	Design load (lb. @ design height)	1235 @ 9.62	
Stabilizer	Type (link, linkless, frameless)	Link	
	Material & bar diameter	HR steel, .8125	

STEERING

Mechanical (std., opt., NA)		Standard		
Power (std., opt., NA)		Not Available		
Wheel diameter		17"		
Turning diameter	Outside front	Wall to wall (l. & r.)	39.0; 38.5	
		Curb to curb (l. & r.)	37.0; 36.5	
	Inside rear	Wall to wall (l. & r.)		
		Curb to curb (l. & r.)		
Side wheel angle with inside wheel at 20°		17°		
Mechanical	Gear	Type	Semi-reversible, worm and ball bearing sector	
		Make	Saginaw	
		Ratios	Gear	Overall
	No. wheel turns	21.0:1	16.3:1 (a)	3.7 (lock to lock) •
Type (coaxial, linkage, etc.)		None		
Make		--		
Trade name		--		
Power	Gear	Type	--	
		Ratios	Gear	Overall
			--	--
	Pump driven by		--	
Number wheel turns		--		
Package	Type		Center point	
	Location (front or rear of wheels, other)		Rear of wheels	
	Drag link (trans. or longit.)		Longitudinal	
	Tie rods (one or two)		Two	

(a) - Special steering - part of heavy-duty chassis option, RPO 687.

(Continued)

Rev. Form 3-59

AMA Specifications - Passenger Car

MAKE OF CAR CHEVROLET MODEL YEAR 1962 DATE ISSUED 10-23-61 REVISED _____

MODEL Corvette

STEERING (cont.)

Steering Axis	Inclination of camber (deg.)		3° 30' - 4° 30'
	Bearings (type)	Upper	Bushing
		Lower	Bushing
		Thrust	Single row ball
Wheel alignment (range and preferred)	Caster (deg.)		2° 0' ± 0° 30'
	Camber (deg.)		0° ± 0° 30'
	Toe-in (outside tread-inches)		.00-.12 per wheel
Steering spindle & joint type			Reverse Elliott
Wheel spindle	Diameter	Inner bearing	1.2801-1.2806
		Outer bearing	.7490-.1495
	Thread size		3/4-20
	Bearing type		Ball

SUSPENSION—REAR

Type and description			Outrigger mounted leaf springs	
Drive and torq. taken through (see page 15)			Rear springs and radius rods	
Spring	Type		Leaf, semi-elliptic	
	Material		Alloy steel	
	Size (length x width, coil design height and I.D.; bar length & dia.)		51.0 x 2.0	
	Spring rate (lb. per in.)		115	
	Rate at wheel (lb. per in.)		-----	
	Design load (lb. at design height)		545-605 @ .08 negative camber height	
	Mounting insulation type		Rubber bushed	
	If leaf	No. of leaves		4 (a)
		Inserts	Type and size	3 Liners; 19.8, 31.8, 46.3 long; 1.9 wide; .11 thick
			Material	Wax impregnated fiber board
Shackle (comp. or tens.)		Tension		
Stabilizer	Type (link, linkless, frameless)		Link	
	Material		Hot rolled steel	
Track bar type			None	

AMA Specifications – Passenger Car

MAKE OF CAR CHEVROLET MODEL YEAR 1962 DATE ISSUED 10-23-61 REVISED _____

BODY—GENERAL DEFINITIONS

NOTE: Included in the dimension definitions listed on this and the following pages are those which have been adopted by S.A.E. These are indicated by a number following the type of dimension, e.g. L 3. Additional dimensions have been added by the AMA Specifications Body Subcommittee for inclusion in the Questionnaire. These are shown by an additional letter, e.g., HA. Symbol "a" added as suffix to SAE dimensions indicates an AMA modification. The dimensions are developed from the following basic points:

1. Body Dimensions are for all basic body models as indicated.
2. All interior dimensions are taken 15" outboard of car centerline (C/L) unless otherwise stated.
3. Front and rear seat free "A" points are taken 5" forward of vertical tangent to seat back 15" from center of body.
4. Depressed "A" point is the lowest point on the seat cushion depressed contour.
5. Front seat is in full down and normal rear position.
6. Unless otherwise specified all exterior height dimensions are taken with a full design load which consists of 5 passengers, 300 lbs. front, 450 lbs. rear; includes spare wheel, tire and tools, and full complement of gas, oil, water and tires to recommended pressure, etc.
7. DLO (Daylight opening - pages 22 & 24).
8. For further clarification of definitions see SAE Aeronautical—Automotive Drawing Standards, Section E-1.

BODY—TRUNK DIMENSIONS

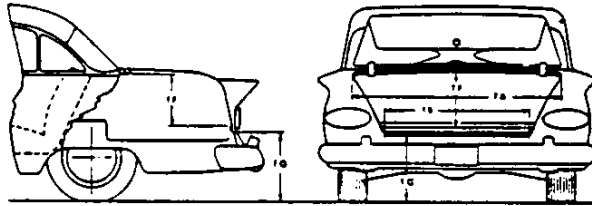

MODEL	Corvette
Available trunk luggage capacity (See Section E-1 of SAE Automotive Drawing Standards)	5.2 cu. ft.
Total trunk volume in cu. ft. with spare tire in place	12.09 cu. ft.
—Width across the top	44.5
—Width across the bottom	Opening is oval
—Vertical dimension at C/L from bottom to top of opening	13.8
—Vertical height from ground to trunk lower opening (normal surface of outside sheet metal - loaded)	26.2
Position of spare tire stowage	Horizontal in trunk under floor
Method of holding lid open	Counterbalance springs

AMA Specifications – Passenger Car

MAKE OF CAR CHEVROLET MODEL YEAR 1962 DATE ISSUED 10-23-61 REVISED _____

BODY—HEIGHT DIMENSIONS—INTERIOR

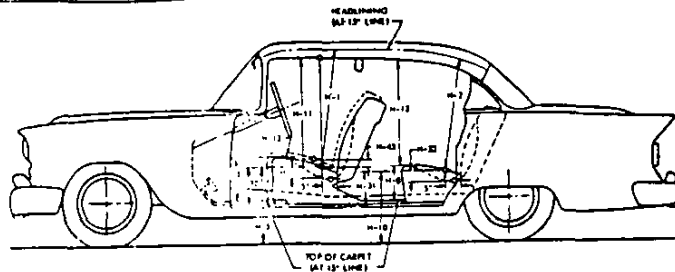

MODEL	Corvette
H1. Front headroom. Free "A" pt. to headlining at 8° back of vertical. (For "A" pt. see note 3, page 20)	Convertible - 35.5 Hardtop - 36.0
H2. Rear headroom. Free "A" pt. to headlining at 8° back of vertical	--
H3. Front cushion height above floor carpet at front edge of cushion. (Ignore risers)	7.7
H5. Free "A" pt. to ground, front. Measured vertically	16.0
H8. Rear cushion height above floor carpet at front edge of cushion. (Ignore risers)	--
H10. Free "A" point to ground rear. Measured vertically	--
H11. Entrance, front. Free "A" point to bottom of windcord, vertical	30.8
H12. Entrance, rear. Top of cushion to bottom of windcord at front edge of rear seat	--
H13. Steering wheel clearance to seat cushion taken on arc (wheel turned for min. clearance)	5.5
H30. Free "A" point reference height, front. Vertical dimension to SAE horizontal reference line	5.2
H31. Free "A" point reference height, rear. Vertical dimension to SAE horizontal reference line	--
H32. Front seat cushion deflection. Vertical dimension from free "A" point to depressed "A" point	2.2
H33. Rear seat cushion deflection. Vertical dimension from free "A" point to depressed "A" point	--
H45. Front seat maximum vertical rise at free "A" point	.2

Rev. Form 3-59

NOTE: Torso room, a depressed dimension, is reported for H1 and H2 dimensions. Free "A" point and depressed "A" point dimensions are replaced with applicable "H" and "D" point dimensions.

AMA Specifications— Passenger Car

MAKE OF CAR CHEVROLET MODEL YEAR 1962 DATE: ISSUED 10-23-61 REVISED (*)

BODY—HEIGHT DIMENSIONS—EXTERIOR

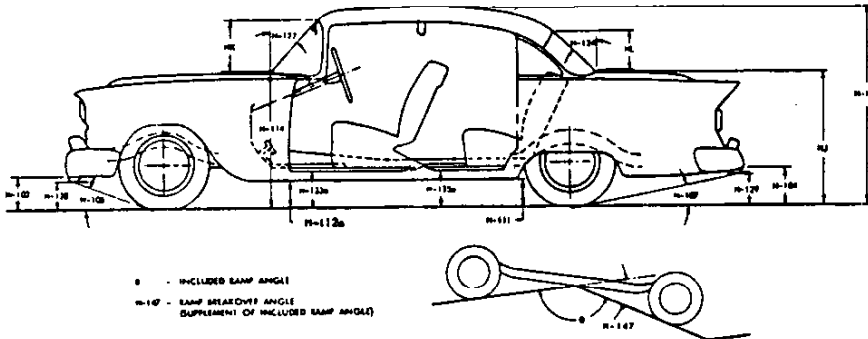

NOTE: For dimensions to lamps see page 12.

MODEL	Corvette
H101. Overall height, full design load	Convertible 52.2 (a); Hardtop 52.1
HB. Overall height, curb weight	Convertible 52.9 (b); Hardtop 52.8
H102. Front bumper bottom to ground at normal section, min. height	17.0
H104. Rear bumper bottom to ground at normal section, min. height	16.4
H106. Angle of approach. To interfering point on bumper, guard, other	21° 18'
H107. Angle of departure. To interfering point on bumper, guard, other	21° 10'
H111. Body Sill to Ground-Rear. Vertical dimension measured from bottom of body sill (rocker panel), excluding any flanges, to ground at front of rear wheel opening.	6.7
H112a. Body Sill to Ground-Front. Measured vertically at foremost point of body sill (rocker panel), excluding flanges and front fender.	7.2
H114. Hood at rear to ground. Vertical dimension C/L, excluding molding, at hood opening line at cowl	36.0
H122. Windshield normal slope angle to vertical line on car C/L	50°
H124. Backlight normal slope angle to vertical line on car C/L	Approx. 47°
H128. Bottom of front bumper guard to ground	9.0
H129. Bottom of rear bumper guard to ground	14.0
H133a. Bottom of front door to ground, min. dimension	13.5
H135a. Bottom of rear door to ground, min. dimension	--
H147. Ramp breakover angle	7° 47'
H153. Min. road clearance at rear axle	8.0
H156. Min. road clearance and location	6.7 (Body sill to ground-rear)
HJ. Deck at rear window to ground	36.4
HK. Windshield DLO°. Vertical height at C/L	11.3
HL. Back light DLO°. Vertical height at C/L	8.3

* See Note, page 20

- (a) Top down - 50.2
- (b) - Top down - 50.8
- (c) - Vertical 5 inch line on the frame.

AMA Specifications—Passenger Car

MAKE OF CAR CHEVROLET MODEL YEAR 1962 DATE: ISSUED 10-23-61 REVISED _____

BODY—LENGTH DIMENSIONS

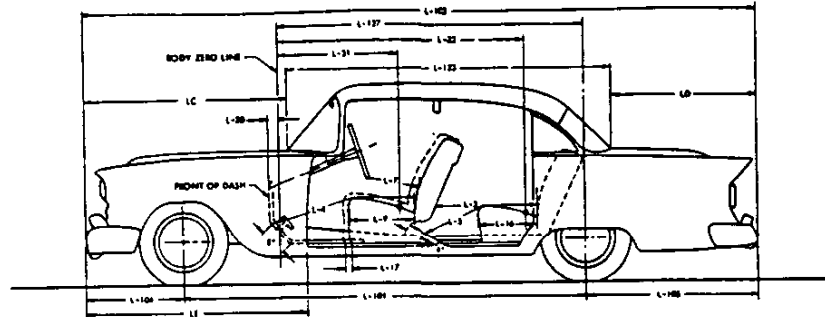

MODEL		Corvette
Interior	L3. Rear compartment room. Back of front seat back to front of rear seat back	--
	L4. Leg room, front. Ball of foot to top of seat to seat back	46.4
	L5. Leg room, rear. Ball of foot to top of seat to seat back	--
	L7. Steering wheel clearance to seat back taken on arc	16.3
	L9. Front seat depth. Front edge to vert. tan. of seat back	18.7
	L16. Rear seat depth. Front edge to vert. tan. of seat back	--
	L17. Maximum "A" point horizontal travel with normal seat adjustment	4.4
	L30. Vertical body zero line to actual front of dash. Measured horizontally*	.5
	L31. Vertical body zero line to free "A" point, front	41.3
	L32. Vertical body zero line to free "A" point, rear	--
Exterior	L101. Wheelbase	102.0
	L103. Overall length. Incl. bumper guards if standard equipment	176.7
	L104. Overhang, front. Include bumper guards if stand. eq.	31.8
	L105. Overhang, rear. Include bumper guards if stand. eq.	42.9
	L123a. Body upper structure length at C/L, excl. molding	60.5
	L127. Vertical body zero line to centerline of rear wheels	74.1
	LC. Front of car to base windshield, excl. molding	69.0
	LD. Rear of car to base of rear window or upper structure, excl. molding	47.5
LE. Front of car to front edge of front door	75.5	

* Precede figure with minus sign if front of dash is to rear of body zero line.

AMA Specifications—Passenger Car

MAKE OF CAR CHEVROLET MODEL YEAR 1962 DATE ISSUED 10-23-61 REVISED (a)

BODY—WIDTH DIMENSIONS

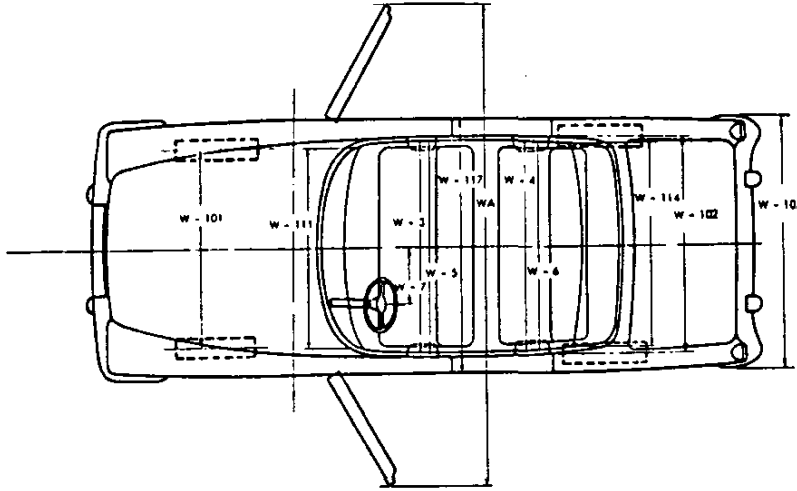

MODEL	Corvette
W3. Front shoulder room, at garnish molding height or nearest interference 5" forward of seat back	49.4
W4. Rear shoulder room, at garnish molding height or nearest interference 5" forward of seat back	--
W5. Front hip room, at top of seat 5" forward of vert. tan. to seat back	59.6
W6. Rear hip room, at top of seat 5" forward of vert. tan. to seat back	--
W7. Steering wheel center (on surface plane of wheel) to C/L of body	13.9
W101. Front tread at ground	57.0
W102. Rear tread at ground	59.0
W103. Max. overall width of car incl. bumpers or moldings (specify location).	70.4
WA. Max. overall width of car with doors open (2 & 4 door)	134.5
W111. Windshield DLO, max. width	53.6
W114. Back window DLO, max. width	Hardtop 48.3; Convertible 35.0
W116a. Maximum overall sheet metal width excl. hardware and applied molding (specify location)	70.4
W117. Max. body width at center pillar, less hardware and applied moldings	70.4

AMA Specifications – Passenger Car

MAKE OF CAR CHEVROLET MODEL YEAR 1962 DATE: ISSUED 10-23-61 REVISED(*) _____

STATION WAGON—CARGO SPACE DIMENSIONS

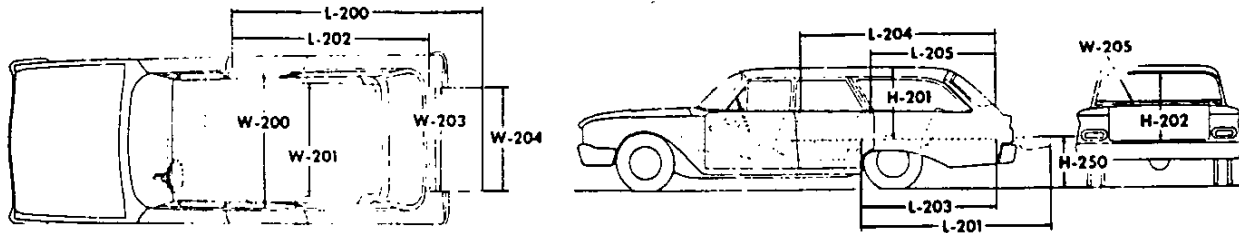

NOTE: Front seat in full down and normal rear position for all measurements. Lengths and heights measured at car centerline.

MODEL	Corvette
L200 Floor length from back of front seat at floor level to end of lowered tail gate	--
L201 Floor length from back of second seat at floor level to end of lowered tail gate	--
L202 Floor length from back of front seat at floor level to inside of closed tail gate	--
L203 Floor length from back of second seat at floor level to inside of closed tail gate	--
L204 Minimum horizontal distance from top rear of front seat back to inside of top of tail gate	--
L205 Minimum horizontal distance from top rear of second seat back to inside of top tail gate	--
w200a Maximum width of cargo space at floor, specify location	--
W201 Minimum distance between wheel houses at floor level	--
W203 Rear end opening width at floor	--
W204 Rear end opening width at top of tail gate	--
W205 Maximum width of rear opening above raised tail gate	--
H201 Maximum height, floor covering to headlining at centerline of rear axle	--
H202 Maximum height of rear opening, tail and lift gates open	--
H250 Platform height measured from ground to top of tail gate floor covering at rear most edge of tail gate, curb weight	--
Third Seat, facing direction	--
Tail and lift gates or sliding glass	--
Cargo volume index (cu. ft.) W4 (P. 24) X L204 X H201	--

1728

AMA Specifications - Passenger Car

MAKE OF CAR CHEVROLET MODEL YEAR 1962 DATE ISSUED 10-23-61 REVISED (6)

MODEL Corvette

BODY - MISCELLANEOUS INFORMATION

Drs. hinged front, rear)	Front doors	Front
	Rear doors	--
Type of finish (lacquer, enamel, other)		Acrylic lacquer
Door hinge location (front, rear)		Front
Door counterbalanced (yes, no)		No
Door release control (internal, external)		Internal
Vehicle (Serial) No. Location		LF body hinge pillar
Engine No. Location		Front right side of cylinder block L. H. side of steering column
Theft protection - type		Ignition, key not removable in "Off" (unlocked) position
Front window control method (crank, friction pivot)	Front	None
	Rear	None
Seat cushion type	Front	Foam rubber, vinyl covered
	Rear	None
Seat back type	Front	Cotton-vinyl covered
	Rear	None
Windshield type (single curved, compound curved, other)		Single curved
Rear window type (flat, curved, one piece, two piece)		Folding top - one-piece flexible plastic Hardtop - one-piece curved plastic
Side glass type (curved, flat)		Flat
Side glass exposed surface area		500 sq. in.
Windshield glass exposed surface area		908 sq. in.
Taillight glass exposed surface area		408 sq. in.
Total glass exposed surface area		1816 sq. in.

AMA Specifications – Passenger Car

MAKE OF CAR CHEVROLET MODEL YEAR 1962 DATE: ISSUED 10-23-61 REVISED 12-1-61

MAJOR OPTIONAL ITEMS - WEIGHTS

	CURB - WEIGHT - POUNDS			% PASS. WEIGHT DISTRIBUTION				SHIPPING * WEIGHT
	Front	Rear	Total	Pass. In Front		Pass. In Rear		
				Front	Rear	Front	Rear	
Model								
867 Convertible			3065					2925
Accessories & Equipment Differential Weights				Remarks				
Hardtop (a)			-15	⊕ (a) In lieu of folding top. (b) In addition to folding top.				
(b)			+55					
Radio			+16					
Top, hydraulic lift equip.			+36					
Transmission, 4-speed			+10					
Transmission, Powerglide			+12					
H. D. Brakes & Spec. Strg.			+40					

* These are weights that are reported to states for licensing purposes. Rev. Form 3-59

INDEX

SUBJECT	PAGE NO.	SUBJECT	PAGE NO.
Air Suspension	17	Lamp Bulbs	11
Angles of Approach, Departure	22	Lamp Height & Spacing	12
Automatic Transmission	1, 14	Legroom	23
Axis, Steering	19	Lengths – Car, & Body Interior	1, 23
Axle, Rear	1, 15	Lifters, Valve	4
		Linings – Clutch, Brake	13, 16
Battery	8	Lubrication	5, 6, 13, 14, 15
Bearings, Engine	3, 4, 7	Motor, Starting	8
Belts – Fan, Generator, Water Pump	7	Muffler	6
Body – General Information, Types	Title, 20	Overdrive	14
Height Dimensions	21, 22	Piston Pins & Rings	3
Length Dimensions	23	Pistons	2, 3
Overall Dimensions	1, 22, 23, 24	Power Brakes	16
Trunk Capacities, Opening Dimensions	20	Power Steering	18
Width Dimensions	24	Propeller Shaft, Universal Joints	15
Brakes – Parking, Service, Power	16, 17	Pumps – Oil, Fuel	6
		Water	7
Camber	19	Radiator, Hoses	7
Camshaft	4	Ramp Break-over Angle	22
Capacities		Ratios – Axle	1, 15
Cooling System	7	Compression	1, 2
Fuel Tank	6	Steering	18
Lubricants		Transmission	13, 14
Engine Crankcase	6	Rear Axle	1, 15
Transmission and Overdrive	13, 14	Regulator – Generator	8
Rear Axle	15	Rims	16
Carburetor	6	Rings, Piston	3
Caster	19	Rods – Connecting	3
Choke, Automatic	6	Shock Absorbers, Front & Rear	17
Circuit Breakers, Fuses	12	Spark Plugs	9
Clearance, Ground	22	Speedometer	10
Clutch – Pedal Operated	13	Springs – Front & Rear Suspension	18, 19
Cognition	9	Valve, Engine	5
Connecting Rods	3	Stabilizer (Sway Bar) – Front & Rear	18, 19
Cooling System	7	Starting Motor	8
Crankshaft	4	Steering	18, 19
Cylinders and Cylinder Head	2	Suppression – Ignition, Radio	9
		Suspension – Front & Rear	17, 18, 19
Distributor – Ignition	9	Switches	10
Electrical System	8, 9, 10, 11, 12	Tailpipe	6
Engine		Thermostat, Cooling	7
Bore, Stroke, Displacement, Type	1, 2	Timing, Engine & Valve	4, 5, 9
Compression Ratio	1, 2	Tires	1, 16
Firing Order, Cylinder Numbering	2, 9	Toe in	19
General Information, H.P. & Torque	1, 2	Torque Converter	1, 2
Lubrication	5, 6	Torque – Engine, Rated	1, 2
Exhaust System	6	Transmission – Types	1, 13, 14
		Automatic	1, 14
Fan, Cooling	7	Manual & Overdrive	13, 14
Filters – Engine Oil, Fuel System	6	Ratios	13, 14
Frame	17	Tread	1, 24
Front Suspension	17, 18	Turning Diameter	18
Fuel, Fuel Pump, Fuel System	1, 2, 6	Unitized Construction	17
Fuel Injection	1, 6	Universal Joints, Propeller Shaft	15
Fuses, Circuit Breakers	12	Valves – Intake & Exhaust	4, 5
		Vibration Damper	4
Generator and Regulator	8	Voltage Regulator	8
Glass	22, 24, 26	Water Pump	7
Height (Lamps)	12	Weights – Shipping, Curb	27
Headroom – Body	21	Wheel Alignment	19
Heights – Car & Body	1, 21, 22	Wheelbase	1, 23
Hood	26	Wheels & Tires	16
Horns	10	Wheel Spindle	19
Horsepower – Brake, Rated, Taxable	1, 2	Widths – Car & Body	1, 24
Ign. System	9	Windshield	22, 24, 26
Inflation – Tires	16	Windshield Wiper	10
Instruments	6, 10		
Kingpin (Steering Axis)	19		