

GENERAL

MODEL IDENTIFICATION	2
SERIAL NUMBERS AND IDENTIFICATION	3
REGULAR EQUIPMENT - EXTERIOR	4
REGULAR EQUIPMENT - INTERIOR	5
REGULAR PRODUCTION OPTIONS AND DEALER INSTALLED ACCESSORIES	6
AIR CONDITIONING EQUIPMENT	7

MODEL IDENTIFICATION

CORVETTE 19437 SPORT COUPE
MODEL 19437 2-DOOR SPORT COUPE, 2-PASSENGER

CORVETTE 19467 CONVERTIBLE
MODEL 19467 2-DOOR CONVERTIBLE, 2-PASSENGER

SERIAL NUMBERS AND IDENTIFICATION

ONLY BASIC DESIGNATIONS SHOWN

VEHICLE SERIAL NUMBER

8-Cylinder Example:

Model	1968	(St. Louis)	100025
19437	8	S	

Thus: The 25th model built at St. Louis would be serial number 194378S100025

ASSEMBLY PLANTS

S - St. Louis

Starting unit number ----- 100001 and up at
each assembly plant regardless of series
Location ----- Stamped on plate attached
to left front body hinge pillar

ENGINE IDENTIFICATION

Example: F1210HE

Source Designation	Production* Month & Date	Type Designation
F(Flat)	1210	HE

327 Cubic Inch 8-Cylinder

HE - Regular engine, 3 or 4-speed, 4-bbl. carb.
HO - Regular engine, Turbo Hydra-Matic

327 Cubic Inch 8-Cylinder (RPO L79)

HT - Optional engine, 4-speed, 4-bbl. carb.

427 Cubic Inch 8-Cylinder (RPO L36)

IL - Optional engine, 4-speed, 4-bbl. carb.
IQ - Optional engine, Turbo Hydra-Matic

427 Cubic Inch 8-Cylinder (RPO L68)

IM - Optional engine, 4-speed, 3 x 2-bbl. carbs.
IO - Optional engine, Turbo Hydra-Matic

427 Cubic Inch 8-Cylinder (RPO L71)

IR - Optional engine, 4-speed, 3 x 2-bbl. carbs.
Mechanical Lifters.

Location:

8-Cylinder engine ----- Stamped on
top front of RH bank of cylinder and case.

* - Month: December, 12; 10th day of December, 10.

TRANSMISSION IDENTIFICATION

Example: RJS8E01D

Type Designation	Source Designation	Model Year 1968	Production* Month & Date E01D*
RJ 3-Speed	S(Saginaw)	8	
WM 4-Speed	V-8 engine		S - Saginaw
-- Turbo Hydra-Matic	V-8 engine		R - Saginaw P - Muncie CC - Ypsilanti

Location:

3-Speed & 4-speed ----- Stamped on
right hand side of the case in the upper forward corner,
4-Speed ----- Stamped on
the top right side of the case.

Turbo Hydra-Matic ----- Nameplate
tag on right hand side of the case.

o-Month: E denotes May; (see below) 01 denotes 1st day

Alpha Characters used in identifying the Calendar Month

A - January	D - April	K - July	R - October
B - February	E - May	M - August	S - November
C - March	H - June	P - September	T - December

* - The letter "D" or "N" following the date numerals
indicates day or night shift.

REAR AXLE IDENTIFICATION

Example: AK0212W

Type Designation	Production* Month & Date	Source Designation
AK	0212	W (Warren)

Regular axles

AK ----- 3.36 ----- 3-speed, 4-speed transmission
AS ----- 3.70 ----- 4-speed transmission

Posttraction axles

AL ----- 3.08 --- 3-speed, 4-speed, & Turbo Hydra-Matic
AM ----- 3.36 ----- 3-speed, 4-speed transmission
AN ----- 3.55 ----- 4-speed transmission
AO ----- 3.70 ----- 4-speed transmission
AP ----- 4.11 ----- 4-speed transmission
AY ----- 2.73 ----- Turbo Hydra-Matic transmission

Location ----- Bottom left or right of
axle tube adjacent to carrier housing

* - Month: February, 02; 12th day of February, 12
c - G-Gear & Axle, B-Buffalo, W-Warren.

REGULAR EQUIPMENT—EXTERIOR

		CORVETTE	
		1966	1967
Body Trim Wheels Chromations	Front and rear bumper guards (integral)	X	X
	Windshield reveal moldings	X	X
	License plate frames, front and rear	X	X
	Parking lamp bezels (clear lens, amber bulb)	X	X
	Radiator grille horizontal bars (silver paint)	X	X
	Hood header emblem (crossed flags)	X	X
	Front and rear side marker lamp bezels	X	X
	Roof drip molding	X	
	Press-flap door handles and push-button key locks	X	X
	Wheel hub caps and trim rings	X	X
	Rear body nameplate (Corvette)	X	X
	Gas filler door emblem	X	X
	Rear license compartment bezel	X	X
	Tail and stop lamp bezels	X	X
	Exhaust pipe extensions and bezels	X	X
	Windshield upper and side garnish moldings	X	X
	Outside rear view mirror	X	X
	Vacuum operated retractable headlamps	X	X
	Concealed 2-speed electric windshield wipers (under vacuum operated cowl panel)	X	X
	Front fender louvers (3-functional)	X	X
Wide body rocker molding (black with bright bead)	X	X	
Removable roof panels (bright center brake moldings and latches)	X		
Folding top (manual; vinyl rear window)		X	
Removable rear window (solid plate with bright frame)	X		
Full-glass front door windows (with "Astro-Ventilation" script)	X	X	
Dual tail lamps	X	X	
Back-up lamps (in lower body panel)	X	X	
Concealed spare tire compartment with key lock	X	X	

REGULAR EQUIPMENT—INTERIOR

		CORVETTE 19400	
		19437	19467
Height Trim And Ornamentation	Hood release lever	X	X
	Body sill plates (black fill)	X	X
	Top header release latches	X	X
	Rear view mirror support	X	X
	Seat back hinge	X	X
	Stowage compartment door trim rings	X	X
	Window and door remote control handles	X	X
	Door locking knobs	X	X
	Directional signal control lever	X	X
	Transmission shift lever and pattern plate lettering	X	X
	Parking brake lever	X	X
	Door trim moldings	X	X
	Console nameplate "Corvette"	X	X
	Heater thumb wheel controls	X	X
	Instrument panel and console control knobs	X	X
	Instrument panel air outlets	X	X
	Console vent controls	X	X
	Deluxe seat belt buckles	X	X
	Removable rear window frame	X	X
	Seat adjuster handle	X	X
Instrument Panel And Console	Electric clock	X	X
	Ammeter, temperature, fuel and oil gauges	X	X
	Tachometer and speedometer with trip odometer	X	X
	Windshield washer and wiper control	X	X
	Cigarette lighter (in ash tray)	X	X
	Parking brake and brake system failure indicator	X	X
	Front and rear lamp monitoring indicators	X	X
Lamps And Switches	Seat belt and door ajar indicators	X	X
	Ignition lock and starter switch, "4-position"	X	X
	Main light and headlamp rotation switch	X	X
	Glove box and lamp (in rear compartment)	X	X
	Luggage lamps	X	X
	Instrument panel courtesy	X	X
	Bucket seats	X	X
	Full-glass door windows with "Astro-Ventilation" script	X	X
	Dual padded sunshades	X	X
	Wood-grain plastic steering wheel, padded horn button with "crossed flags"	X	X
	Carpeted floor and luggage area	X	X
	Padded headlining	X	
	Molded door panels with built-in armrests	X	X
	Roof panels and rear window stowage shelf	X	
	Center console trim plates (black with crossed flags)	X	X

REGULAR PRODUCTION OPTIONS AND DEALER INSTALLED ACCESSORIES

Equipment	RPO/ACC	Models
Air conditioner, Four-Season	C60	19400
Axis ratios		
2.73 ratio	*	19400
3.08 ratio	*	19400
3.36 ratio	*	19400
3.55 ratio	*	19400
3.70 ratio	*	19400
4.11 ratio	*	19400
Positraction (all ratios)	G81	19400
Brakes, heavy duty	J56	19400
Brakes, power	J50	19400
Carrier, deck lid luggage		ACC 19467
Carrier, ski (deck lid)		ACC 19467
Compass		ACC 19400
Emergency road kit		ACC 19400
Engines		
Aluminum cylinder heads	L89	19400
390 hp Turbo-Jet 427 Cu.in. V-8	L36	19400
400 hp Turbo-Jet 427 Cu.in. V-8	L68	19400
430 hp Turbo-Jet 427 Cu.in. V-8	L88	19400
435 hp Turbo-Jet 427 Cu.in. V-8	L71	19400
350 hp Turbo-Fire 327 Cu.in. V-8	L79	19400
Exhaust system, off-road service	N11	19400
Fire extinguisher (2-3/4 lb. dry chemical)		ACC 19400
Fire extinguisher refill cartridge		ACC 19400
Floor mats, clear vinyl twin		ACC 19400
Glass, tinted window	A01	19400
Glass, tinted windshield	A02	19400
Head restraint, standard	A82	19400
Ignition, full-transistor	K66	19400
Lock, gas cap		ACC 19400
Mirror, visor vanity		ACC 19400
Radio and rear antenna, push-button AM-FM	U69	ACC 19400
Radio antenna, rear fixed height		ACC 19400
Roof cover, vinyl	C08	19467
Seat, child restraint		ACC 19400
Seat pad, ventilated		ACC 19400
Shoulder harness, deluxe	A85	19400
Speed warning indicator	U13	19400
Spotlight, hand portable		ACC 19400
Steering, power	N40	19400
Steering shaft, telescopic	N36	19400
Stereo-multiplex	U79	19400
Suspension, special performance front and rear	F41	19400
Tires		
P70-13-4 pr tire-special nylon-red stripe	PT6	19400
P70-13-4 pr tire-special nylon-white stripe	PT7	19400
Tissue dispenser, instrument panel mounted		ACC 19400
Top, auxiliary	C07	19467
Top, folding convertible	C05	19467
Transmissions		
4-speed (2.52 low)	M20	19400
4-speed close ratio (2.20 low)	M21	19400
3-speed automatic, Turbo Hydra-Matic	M40	19400
Wheel covers	P01	19400
Windows, power	A31	19400

* Positraction only.

AIR CONDITIONING EQUIPMENT

FOUR-SEASON (RPO C60)

Heater integrated; manually controlled by knobs on instrument control panel, that operate bowden cables to activate various doors and switches to operate system.

BASIC COMPONENTS

Evaporator, blower, condenser, receiver-dehydrator, refrigerant (freon) tank, air intake assembly and duct assembly for both systems.

EQUIPMENT (Used in addition to or in place of base equipment)

CHASSIS

Front and Rear Springs ----- Heavy duty
Rear Axle Ratio - Refer to Power Trains Section

POWER TRAINS

Fan Blade ----- 7 blade
Crankshaft Pulley ----- Dual
Water Pump & Fan Pulley ----- Dual
Compressor & Crankshaft Belt ----- One*
Generator ----- 63 Ampere

* Additional equipment; also brackets, supports, braces, hoses, etc. as required for installation.

Heavy duty cooling equipment must be used on V-8 powered vehicles. It is recommended that this equipment also be used on all other vehicles for securing maximum air conditioning performance.



CHASSIS

FRAME AND FRONT SUSPENSION	2
STEERING, DRIVELINE, WHEELS AND TIRES	3
REAR AXLE AND SUSPENSION	4
BRAKES	5
BULBS AND LAMPS	6
FUSES AND CIRCUIT BREAKERS	7

FRAME AND FRONT SUSPENSION

FRAME

Description ----- All welded, full length, ladder constructed frame with 5 crossmembers. Side rails and intermediate crossmembers box section; front crossmember box girder section. Eight body mounting points.

FRONT SUSPENSION

Description ----- Independent, SLA type, coil springs with center mounted shock absorbers, spherical joint steering knuckle pivots.

Wheel travel (design)

Total ----- 7.84

Jounce ----- 3.86

Rebound ----- 3.98

Wheel to spring, travel ratio ----- 1.63

CONTROL ARMS

Description ----- Reinforced steel stamping with pre-loaded steel encased rubber bushings at pivot.

STEERING KNUCKLES

Description ----- Forged steel, with integral brake caliper mounting pads and detachable steering knuckle arm

Spindle diameters

Inner bearing ----- 1.2493-1.2498

Outer bearing ----- .7492-.7497

Spindle thread size ----- 3/4-20 NEF-3 (modified)

Wheel bearings

Type ----- Taper roller

SPHERICAL JOINTS

Type ----- Ball stud

Upper ----- Compression

Lower ----- Compression

Bearing surfaces

Upper ----- Teflon-coated phenolic

Lower ----- Teflon-coated phenolic

SHOCK ABSORBERS

Type ----- Direct, double-acting, hydraulic

Piston diameter ----- 1.00

STABILIZER BAR

Type ----- Link

Material ----- HR steel

Diameter ----- 327 V-8, .750; 427 V-8, .9375

Bushing material ----- Rubber

FRONT WHEEL ALIGNMENT (CURB)

Camber (degrees) ----- P1/4 to P1-1/4

Caster (degrees) ----- P1/2 to P1-1/2

Toe-in (total) ----- 3/32 to 5/32

Steering Axis Inclination (degrees) ----- 6-1/2 to 7-1/2

GENERAL SUSPENSION PROVISIONS

Car leveling ----- Front stabilizer bar

Anti-dive control --- Angle of front upper control arm

FRONT SPRINGS

Part Number	Ref.	Type	Material	Cut-off Length	Wire Dia.	Inside Dia.	Heights		Deflection Rate (lbs per inch)	
							Working (in. @ lbs)	@ Spring	@ Wheel	
3931823	A	Coil, R.H. helix	Steel alloy	138.25	.600	3.80	9.99 @ 1395	250		
3931825	B			138.75	.618	3.80	9.99 @ 1540	284		

Engine	327 Cu.In. V-8	427 Cu.In. V-8
Model	19400	19400
Reference	A	B

STEERING, DRIVELINE, WHEELS AND TIRES

MANUAL STEERING, regular production

Description ----- Semi-reversible, recirculating bearing ball nut steering gear, energy absorbing steering column, steering damper attached to relay rod; two-position steering knuckle arm attachment for street and fast ratio steering. Telescoping steering wheel available optionally.

System ratios

Steering gear ----- 16:1
 Overall ratio
 Street ----- 20.2:1
 Fast ----- 17.6:1

Turning diameters (ft)

Outside front, wall to wall -----
 Outside front, curb to curb -----
 Inside rear, wall to wall -----
 Inside rear, curb to curb -----

Number of wheel turns, lock to lock

Street ----- 3.4
 Fast ----- 2.92

Outside wheel angle with inside wheel

@ 15 degrees ----- 14.25
 @ 20 Degrees ----- 18.47
 @ 34 degrees (limit of turn) ----- 27.34

Linkage ----- Parallelogram type,
 rear of front wheels

Steering wheel

Standard and optional telescoping wheel ----- Deep
 dished, 16.0 diameter

POWER STEERING, RPO N40

(Same as standard manual steering except as shown)

Description ----- Hydraulic; pump
 powered cylinder assisting linkage

Ratios ----- Gear, 16:1; overall, 17.6:1
 Number of wheel turns, lock to lock ----- 2.92

DRIVELINE

Type ----- Tubular
 Number used ----- One
 Diameter (OD) Manual ----- 1.995-2.003
 Turbo Hydra-Matic ----- 2.250
 Length (C/L of U-joints) Manual ----- 29.90
 Turbo Hydra-Matic --- 29.50
 Wall thickness ----- .092-.097
 Universal joints
 Type ----- Cross
 Number used ----- Two
 Bearings ----- Prepack, anti-friction
 Drive and torque forces ----- Through rear
 suspension control arms

WHEELS (Regular Production)

Type ----- Short spoke spider
 Attachment to hub ----- 5 hex nuts, 7/16-20 UNF 2-B,
 arranged on a 4.75 diameter bolt circle
 Offset ----- N.28
 Rim size ----- 15 x 7.00

TIRES

Construction ----- 2 ply
 Size and ply rating ----- F70-15-4PR
 Specifications
 Static Loaded Radius ----- 12.6
 Loaded rev/mt @ 50 MPH ----- 776
 Capacity (lb @ psi) ----- 1280 @ 24
 Recommended inflation, all tires, psi ----- 24

REAR AXLE AND SUSPENSION

REAR AXLE

Description ----- Fixed differential housing hypoid ring and pinion gear set, tubular articulating inner axle shafts and short solid outer shafts with integral drive flange, independently sprung rear wheels

Pinion offset ----- 1.5

Pinion bearing adjustment ----- Shim

Hypoid gear PD all except 2.73:1 ratio ----- 8.375

2.73:1 ratio ----- 8.125

Type ----- Military Spec. MIL-L-2105-B

Viscosity ----- SAE80

Filler plug ----- 1-3/8 hex, 1-20 AN thread

Capacity (pcs) ----- 3.7

RING AND PINION GEARS

Ratio	Tooth Combination
2.73	41,15
3.08	37,12
3.36	37,11
3.55	32,9
3.70	37,10
4.11	37,9

AXLE SHAFTS

Inner ----- Welded steel tubing with universal joint attachments to short shafts at each end.

Outer ----- Short, splined high-alloy steel with integral wheel mounting flange

Axle bearings

Type ----- Inner and outer tapered roller, steel encased rubber bearing seals

REAR WHEEL

Description ----- Brake disc flange integral with axle which is universally-joined (thru splined axle flange) to axle shaft; torque control arm bolted to axle support. Axle supported by two taper roller bearings

REAR SUSPENSION

Description ----- Full independent with frame-anchored differential. Position of each wheel established by 3 links: tubular drive shafts, transverse strut rods, torque control arms. Vertical suspension loads taken by transverse leaf spring. Built-in camber adjustment at strut rod inner ends.

Wheel travel (design height)

	Coupe	Conv.
Total	6.86	6.86
Jounce	2.87	2.76
Rebound	3.99	4.10

Wheel to spring, travel ratio ----- 0.90:1

SHOCK ABSORBERS

Type ----- Direct, double-acting, hydraulic

Piston diameter ----- 1.00

STRUT

Material ----- Forged steel

Diameter ----- .75

STABILIZER BAR (427 V-8)

Diameter ----- .362

REAR WHEEL ALIGNMENT

Curb

Camber (degrees) ----- N1-3/8 to N 3/8

Toe-in (total) ----- 1/32 to 3/32

TORQUE CONTROL ARMS

Description ----- Welded steel box construction

REAR SPRING

Type ----- Variable rate, 9-leaf

Material ----- Chrome carbon steel, heat treated

Length (developed) between eye centers ----- 46.36

Width ----- 2.25

Design load, lb @ -camber ----- 1360 @ .352

Deflection rate, lb per inch, @ design load

@ Spring ----- 140

@ Wheel (wheel rate) ----- 123

Spring liners

Number ----- 7

Location ----- Between all leaves except numbers 6 and 7

Material ----- Polyethylene with graphite

BRAKES

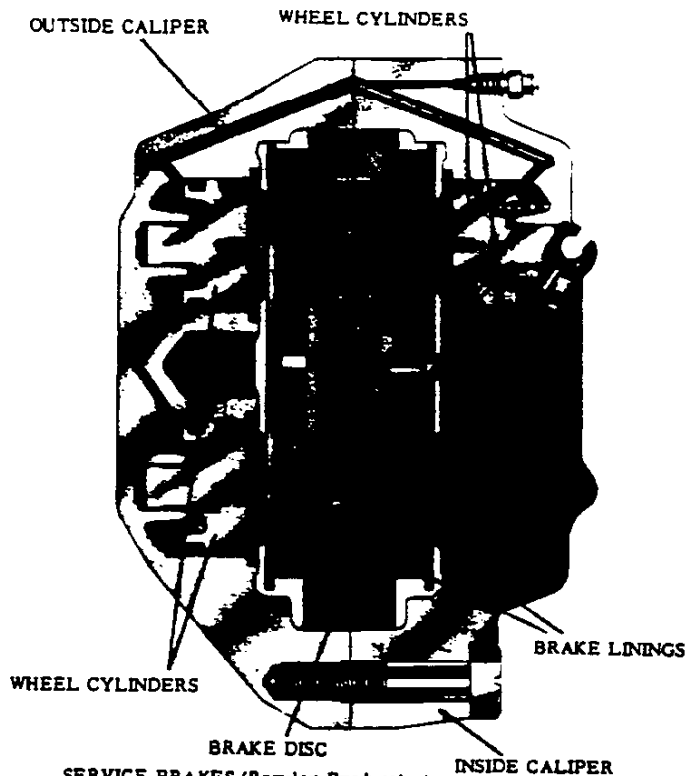

PARKING BRAKE

Type ----- Drum; cast integral with each rear rotor. Internal expanding shoe, mechanically actuated
 Control ----- Lever; floor mounted in center console
 Drum diameter ----- 6.5
 Brake lining
 Number ----- 2 shoes per each rear wheel
 Size (L x W x T) ----- 6.78 x 1.25 x .175
 Gross lining area (sq.in.) ----- 33.9

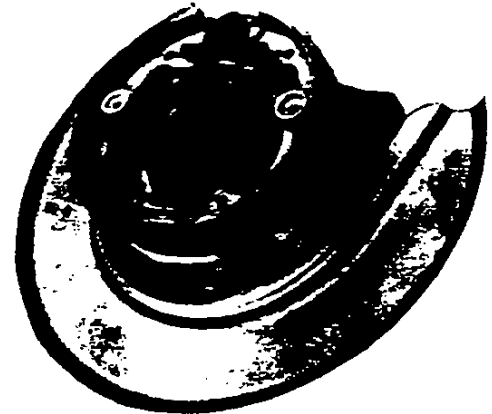

PARKING BRAKE

SERVICE BRAKES (Regular Production)

Type ----- Dual-circuit
 brake system, pressure differential and parking brake warning light, 4 wheel hydraulic caliper disc brakes
 Line pressure; psi, @ 100 lb pedal load ----- 576
 Braking ratios
 Pedal ----- 4.52
 Hydraulic ----- 43.3
 Overall ----- 196.0
 Distribution of braking effort ----- Front 65.0
 Brake disc
 Construction ----- Double faced disc spaced by integrally cast radial cooling passages
 Material ----- Cast iron
 Diameter, front & rear ----- 11.75
 Swept drum area (sq.in.) ----- 461.2
 Brake lining
 Material ----- Woven asbestos
 Size, all segments (L x W x T) ----- 5.96 x 2.21 x .41
 Method of attachment ----- Riveted
 Total effective area (sq.in.) ----- 78.1
 Gross lining area (sq.in.) ----- 86.3
 Master cylinder
 Piston diameter ----- 1.00
 Piston travel (with available pedal travel) ----- 1.10
 Wheel cylinders
 Number ----- 4 per wheel
 Piston diameter
 Front ----- 1.875
 Rear ----- 1.375
 Foot pedal travel ----- 5.75

BULBS AND LAMPS

BULBS AND LAMPS	NUMBER REQUIRED AND TRADE NUMBER	CANDLE POWER PER LAMP
Air conditioning	2-1891	2
Back-up	2-1156	32
Cigarette lighter	1-1445	1
Clock	1-1895	2
Courtesy		
Instrument panel	2-631	6
Rear compartment	1-631	6
Direction signal indicator	2-1895	2
Dome	1-212	6
Glove compartment	1-1895	2
Headlamp Outer	2-4002	High beam 37.5W Low beam 55.0W
inner	2-4001	High beam 37.5W
Headlamp hi-beam indicator	1-1895	2
Headlamp warning indicator	1-257	2
Heater	1-1895	2
Ignition switch	1-1895	2
Instrument cluster	12-1895	2
License plate rear	1-67	4
Parking		
Park		4
Turn	2-1157	32
Parking brake alarm & warning light	1-1895	2
Radio	1-1893	2
Seat separator box	1-1895	2
Side Marker - Front	2-194A	2
Side Marker - Rear	2-194	2
Spot lamp, portable	1-4416	30W
Tail		
Stop and turn	4-1157	32
Tail		4
Underhood	1-93	15

FUSES AND CIRCUIT BREAKERS

CIRCUIT	TYPE OF PROTECTION	LOCATION AND CIRCUIT*
Air conditioning	AGC 25 fuse	In line
Air conditioning lamp	AGC 25 fuse	Fuse panel (f)
Back-up lamps	AGC 4 fuse	Fuse panel (d)
Cigarette lighter	AGC 20 fuse	Fuse panel (b)
Cigarette lighter lamp	AGC 20 fuse	Fuse panel (c)
Clock	AGC 4 fuse	Fuse panel (d)
Clock lamps	AGC 20 fuse	Fuse panel (c)
Courtesy lamps	AGC 4 fuse	Fuse panel (d)
Defogger, rear window	AGC 20 fuse	Fuse panel (c)
Direction signal indicator lamp	AGC 20 fuse	Fuse panel (d)
Dome lamp	AGC 20 fuse	Fuse panel (c)
Fuel gage	AGC 10 fuse	Fuse panel (b) -
Glove compartment lamp	AGC 20 fuse	Fuse panel (c)
Headlamp hi-beam indicator lamp	15 amp CB	Light switch (g)
Headlamp warning indicator lamp	40 amp CB	Hinge pillar (h)
Headlamps	15 amp CB	Light switch (g)
Heater	AGC 25 fuse	Fuse panel (f)
Heater lamp	AGC 4 fuse	Fuse panel (d)
Ignition switch lamp	AGC 4 fuse	Fuse panel (d)
Instrument cluster lamps	AGC 4 fuse	Fuse panel (d)
License plate, rear	AGC 20 fuse	Fuse panel (a)
Brake warning lamp	AGC 10 fuse	Fuse panel (b)
Parking lamps	15 amp CB	Light switch (g)
Power windows	40 amp CB	Hinge pillar (i)
Radio	AGC 10 fuse	Fuse panel (e)
Radio antenna	AGC 20 fuse	Fuse panel (c)
Radio lamp	AGC 4 fuse	Fuse panel (d)
Rear compartment vent motor	AGC 10 fuse	Fuse panel (f)
Speed warning device	AGC 20 fuse	Fuse panel (c)
Side Marker lamp - Front	AGC 20 fuse	Light switch
Side Marker lamp - Rear	AGC 20 fuse	Light switch
Spot lamp, portable	AGC 20 fuse	Fuse panel (c)
Stop lamps	AGC 20 fuse	Fuse panel (d)
Tail lamps	AGC 20 fuse	Fuse panel (a)
Temperature gage	AGC 10 fuse	Fuse panel (b)
Traffic hazard indicator	AGC 20 fuse	Fuse panel (c)
Windshield wiper	14 amp CB	Switch (j)

* Letter suffix indicates same circuit



DIMENSIONS AND WEIGHTS

INTERIOR DIMENSIONS	2
EXTERIOR DIMENSIONS	3
VEHICLE WEIGHTS	4

INTERIOR DIMENSIONS

FRONT COMPARTMENT

CODE	DESCRIPTION	19437 COUPE	19467	
			SOFT TOP	HARDTOP
H5	H point to ground		14,6	
H30	H point to heel point		6,5	
H37	Headlining to roof height	0,7	---	0,9
H54	D point to tunnel		2,9	
H58	H point rise		0,4	
H61	Effective headroom	36,2	37,1	36,0
H65	D point differential, side to center			
H67	Depressed floor covering thickness		0,3	
H70	Body zero line to H point (vert.)		7,0	
L17	H point travel		4,5	
L31	Body zero line to H point (horiz.)		44,7	
L34	Maximum effective leg room - accelerator		43,0	
L40	Back angle (degrees)		33	
L42	Hip angle (degrees)		107	
L44	Knee angle (degrees)		138	
L46	Foot angle (degrees)		88	
L53	H point to accelerator floor point		36,0	

SEAT AND ENTRANCE

H3	Seat chair height		8,8	
H11	Entrance height		29,0	
H26	Interior body height, M/M @ car centerline	33,4	33,6	33,4
H27	Interior body, M/M @ C/LO	40,0	40,2	40,0
H32	Seat cushion deflection		2,2	
H50	Upper body opening to ground		43,6	
W1	Hat room		45,5	
W3	Shoulder room		46,9	
W5	Hip room		48,8	
W16	Seat width (each seat)		20,0	
L14	Seat back thickness		3,5	
L18	Entrance foot clearance		13,2	

VISION AND CONTROL

H6	H point to W/S bottom DLO		19,8	
H13	Steering wheel thigh clearance		4,2	
H18	Steering column angle (degrees) horizontal		14	
H25	Belt height		17,4	
H49	H point to top of steering wheel		22,5	
H64	H point to W/S upper DLO		29,1	
W7	Steering wheel center to car centerline		12,9	
W9	Steering wheel maximum O.D.		16,0	
W122	Tumble-home (degrees)		26,0	
L7	Steering wheel torso clearance		12,4	
L13	Brake pedal knee clearance		24,5	
L49	H point to W/S upper DLO		12,4	
L52	Brake pedal to accelerator		4,0	

EXTERIOR DIMENSIONS

LENGTHS

CODE	DESCRIPTION	19437			19467		
		COUPE			SOFT TOP	HARDTOP	
L101	Wheelbase				98.0		
L102	Tire size (standard)				F70-15		
L103	Overall length				182.1		
L104	Overhang - front				40.2		
L105	Overhang - rear				43.9		
----	Overall length - less bumpers				179.2		
L123	Body upper structure length at car C/L	54.7					
L127	Body O line to C/L of rear wheels				72.0		
L128	Hood length at centerline				54.4		
L129	Deck length @ car C/L	45.6					48.2
L130	Body zero line to W/S cowl point				11.6		

WIDTHS

W101	Tread - front				58.3		
W102	Tread - rear				59.0		
W103	Maximum overall width of car (W106)				69.2		
W106	Front fender overall width				69.2		
W107	Rear fender overall width				68.6		
W120	Overall car width, front doors open				130.8		
W122	Tumble-home (degrees)				26.5		

HEIGHTS

H101	Overall height (design)	47.8					
----	Overall height (curb)						
H102	Front bumper to ground				9.2		
H104	Rear bumper to ground				12.3		
H111	Rocker panel to ground - rear				7.6		
H112	Rocker panel to ground - front				7.6		
H114	Hood at rear to ground				26.6		
H115	Step height - front (design)				13.1		
H122	W/S slope angle (degrees)				57		
H125	Headlamp to ground				17.5		
H126	Tail lamp to ground				25.7		
H130	Step height - front (curb)				13.1		
H132	Bottom of door to ground - open						
H133	Bottom of door to ground - closed				10.0		
H136	Body O line to ground - front				7.6		
H137	Body O line to ground - rear				7.6		
H158	Roof thickness	3.3			4.0		3.8
H159	DLO height	11.5					11.9
H160	Body thickness				25.3		

CLEARANCES

H106	Angle of approach (degrees)				22		
H107	Angle of departure (degrees)				21		
H147	Ramp breakover angle (degrees)				22		
H148	Front suspension to ground				3.7		
H149	Oil pan to ground				4.8		
H150	Flywheel housing to ground				5.2		
H151	Frame to ground				5.4		
H152	Exhaust system to ground				4.9		
H153	Rear axle to ground						
H154	Fuel tank to ground				Mounted over tire well		
H155	Tire well to ground				5.1		
H156	Minimum ground clearance (H152)				4.9		

VEHICLE WEIGHTS

CORVETTE

Model Symbol	VEHICLE TYPE Description	SHIPPING WEIGHT			CURB WEIGHT		
		Front	Rear	Total	Front	Rear	Total
19437	2-Door Sport Coupe	1570	1485	3055	1570	1640	3210
19467	2-Door Convertible	1570	1495	3065	1565	1655	3220

SHIPPING WEIGHT: Weight of basic vehicle with regular equipment and grease and oil. Weight of gasoline and water not included.

CURB WEIGHT: Weight of empty vehicle ready to drive. Shipping weight plus the weight of gasoline and water.

For total shipping, and curb, weights of vehicles equipped with the following options, add to, or deduct from, the base vehicle weight (lbs).

RPO	Option	Weight
A31	Power Windows	+ 5
C07	Auxiliary Top	+ 48
C60	Air Conditioning	+ 95
J50	Power Brakes	+ 10
J56	Heavy Duty Brakes	+ 6
L36	427 Cu. In. V-8	+178
L68	427 Cu. In. V-8	+ 4
L71	427 Cu. In. V-8	+149
L79	327 Cu. In. V-8	+ 12
L89	Aluminum Cylinder Heads	- 73
M20	4-Speed Transmission	- 6
M40	3-Speed Automatic Transmission	+ 63
N40	Power Steering	+ 21
U69	Radio - AM/FM Push-Button	+ 16
U79	Radio Stereo Equipment	+ 11

BODY

EXTERIOR PAINT PROCESS	2
EXTERIOR-INTERIOR COLORS	3
BODY CONSTRUCTION AND GLASS AREA	4

EXTERIOR PAINT PROCESS

1. **PRIMARY SANDING.** All body panels and bonded joints that receive acrylic lacquer are dry sanded to prepare surfaces for painting. A filler material, called putty rub, is applied to the entire body to fill minor imperfections.
2. **PRIMER.** Two coats of primer are applied -- the first red and the second gray -- and are oven baked for 60 minutes at 280 degrees F.
3. **WET SANDING.** The body is wet sanded to provide a smooth surface for the sealers. Most of the gray primer coat is removed with the red primer acting as a depth signal for the sanding operation. The body is dried to remove all moisture.
4. **SEALER.** One coat of sealer and one coat of color acrylic lacquer are applied and baked.
5. **DRY SANDING.** The body is dry sanded to prepare surfaces for the final acrylic lacquer.
6. **LACQUERING.** Three coats of acrylic lacquer are sprayed on the body to build up the required paint thickness. The paint is "rested" for eight minutes to permit it to partially set up and to remove excess volatile paint vehicle.
7. **INITIAL BAKING.** The body is oven baked for 30 minutes at 140 degrees F to harden the paint which permits the subsequent operation. Small interior and exterior parts are painted to complete the body paint schedule.
8. **FINAL BAKING.** To assure a durable, hard, high luster finish the lacquer is oven baked for 45 minutes at 250 degrees F. Reheating the lacquer permits the paint film to soften and allows surface blemishes and sanding scratches to disappear during the thermo-reflow process.
9. **FINAL SANDING AND POLISHING.** The body is lightly oil sanded and polished to bring painted surfaces to a high luster finish.

EXTERIOR-INTERIOR COLORS

CORVETTE

MODELS		TRIM	INTERIOR COLORS AND RPO NUMBERS						
37	67		Black	Red	Med. Blue	Dark Blue	Dark Orange	Tobacco	Gun Metal
X	X	Vinyl	Prod.	407	414	411	425	435	442
X	X	Leather	402	408	415	--	426	436	--
RPO	EXTERIOR COLOR								
900	Black		X	X	X	X	X	X	X
972	White		X	X	X	X	X	X	X
974	Red		X	X	--	--	--	--	--
976	Medium Blue		X	--	X	X	--	--	--
978	Dark Blue		X	--	X	X	--	--	--
983	Dark Green		X	--	--	--	--	--	--
984	Yellow		X	--	--	--	--	--	--
986	Silver		X	--	--	X	--	--	X
988	Maroon		X	--	--	--	--	--	--
992	Copper Bronze		X	--	--	--	X	X	--

Convertible top: Black (regular production) - Beige or white (RPO C05) with any exterior color.

Vinyl top (RPO C08): Black with any exterior color for removable hardtop models.

BODY CONSTRUCTION AND GLASS AREA

GENERAL

Construction ----- Uniconstruction: fiber glass reinforced plastic body backbone by a steel cage outlining the passenger compartment. Principal members - underbody, front and rear end assemblies, dash panel and hinge pillars are bonded, riveted, or bolted together and to each other. Hood is plastic with bonded plastic reinforcement. Coupe: two removable roof panels and removable rear window.

DOORS AND LOCKS

Construction ----- Plastic, double paneled, reinforced with steel at hinge and lock locations. Front hinged.
 Door handles ----- Push-button and press-flap handles with fork-type latches. Inside door locking knob on each door, free-wheeling 2-position inside door handles.

HOOD

Operation ----- Internal release lever. Front hinged with telescoping link on right side. Ratchet-type lock for hold open.

VENTILATION

Type ----- "Saddlebag" cowl top air inlets channel air to cowl side kick panel outlets controlled by bowden cable and slide type levers mounted in instrument panel center console. Water drainage at base of "saddlebag" plenum chambers.

SEATS

Type and construction ----- Bucket; leather grained vinyl covering over polyurethane padding.

WINDSHIELD WIPERS

Type ----- Concealed, dual, two-speed, electric vacuum operated cowl panel; washer provided.
 Linkage ----- Parallel acting

HEADLIGHTS

Type ----- Vacuum operated, retractable

SPARE TIRE

Location ----- In well under fuel tank; accessible from underside of car. Cover with key lock provided.

TOOLS

Type ----- Scissors jack, and combination jack handle and lug wrench.
 Stowage ----- In well in luggage area directly behind passenger seat; carpeted door over well.

BODY GLASS VISIBILITY AREA

LOCATION	MODELS	
	37	67
Windshield		
Front door window		
Rear quarter window		
Back window		
Total area (sq.in.)		

POWER TRAINS

POWER TRAIN COMBINATIONS	2
POWER TRAIN MULTIPLICATION FACTORS	2
ENGINE DATA AND RATINGS	3
ENGINE SPEED AND PISTON TRAVEL	3
VEHICLE PERFORMANCE FACTORS	4
ENGINE OUTPUT CURVES	5
PRINCIPAL COMPONENTS	6
FUEL SYSTEM	11
EXHAUST AND VENTILATION SYSTEM	11
LUBRICATION SYSTEM	12
COOLING SYSTEM	13
ELECTRICAL SYSTEM	14
CLUTCHES	15
THREE AND FOUR SPEED TRANSMISSIONS	15
TURBO HYDRA-MATIC TRANSMISSION	16

POWER TEAM COMBINATIONS

ENGINE	TRANSMISSION	MODEL APPLICATION	AXLE RATIOS (A)						
			2.73:1	3.08:1	3.36:1	3.55:1	3.70:1	4.11:1	
327 Cu.In. V-8 Turbo-Fire 327 300 HP Standard	3-Spd (2.54:1 low) & 4-Spd (2.52:1 low)	All Models		Econ.#	Std.*				
	Turbo Hydra-Matic			Std.#					
327 Cu.In. V-8 Turbo-Fire 327 350 HP RPO L79	4-Spd (2.52:1 low)	All Models			Std.*	Perf.#			
	4-Spd (2.20:1 low)						Std.*	Perf.#	
427 Cu.In. V-8 Turbo-Jet 427 390 HP RPO L36	4-Spd (2.52:1 low)	All Models		Std.#	Perf.#				
	4-Spd (2.20:1 low)			Econ.#	Std.#	Perf.#	Spcl.#		
	Turbo Hydra-Matic		Econ.#	Std.#					
427 Cu.In. V-8 Turbo-Jet 427 400 HP RPO L68	4-Spd (2.52:1 low)	All Models		Std.#	Perf.#				
	4-Spd (2.20:1 low)			Econ.#	Std.#	Perf.#	Spcl.#		
	Turbo Hydra-Matic		Econ.#	Std.#					
427 Cu.In. V-8 Turbo-Jet 427 435 HP RPO L71	4-Spd (2.20:1 low)	All Models			Econ.#	Std.#	Perf.#	Spcl.#	

(A) Air conditioning available with the same engine, transmission, axle combinations except RPO L71.

- * Positraction axles available optionally.
- # Available as positraction only.

Std. - Standard
Econ. - Economy (optional)
Perf. - Performance (optional)
Spcl. - Special (optional)

MULTIPLICATION FACTORS

WITH MANUAL TRANSMISSIONS

ENGINE	CARBURETION	TRANSMISSION	TOTAL GEAR REDUCTION					AXLE RATIO
			1st	2nd	3rd	4th	Rev	
327 Cu.In. V-8 300 HP Standard	4-Barrel	3-Speed (2.54:1)	8.53	5.04	3.36		8.84	3.36
		4-Speed (2.52:1)	8.47	6.32	4.91	3.36	8.70	
327 Cu.In. V-8 350 HP RPO L79	4-Barrel	4-Speed (2.52:1)	8.47	6.32	4.91	3.36	8.70	3.36
		4-Speed (2.20:1)	8.14	6.07	4.70	3.70	8.36	3.70
427 Cu.In. V-8 390 HP RPO L36	4-Barrel	4-Speed (2.52:1)	7.76	5.79	4.50	3.08	7.98	3.08
		4-Speed (2.20:1)	7.39	5.51	4.27	3.36	7.59	3.35
427 Cu.In. V-8 400 HP RPO L68	3 x 2-Barrel	4-Speed (2.52:1)	7.76	5.79	4.50	3.08	7.98	3.08
		4-Speed (2.20:1)	7.39	5.51	4.27	3.36	7.59	3.36
427 Cu.In. V-8 435 HP RPO L71	3 x 2-Barrel	4-Speed (2.20:1)	7.81	5.82	4.51	3.55	8.02	3.55

WITH AUTOMATIC TRANSMISSIONS

ENGINE	TRANSMISSION	SELECTOR POSITION	TOTAL TORQUE MULTIPLICATION	AXLE RATIO
327 Cu.In. V-8 Standard and 427 Cu.In. V-8 RPO L36 & L68	Turbo Hydra-Matic	Drive	17.56:1 - 3.08:1	3.08:1
		Low	17.56:1 - 7.64:1	
		Second	17.56:1 - 4.56:1	
		Reverse	14.72:1 - 6.41:1	

ENGINE DATA AND RATINGS

GENERAL DATA

Engine Type	V-8 OHV				
Piston Displacement (Cu. In.)	327		427		
Availability	Standard	RPO L79	RPO L36	RPO L68	RPO L71
Number of Cylinders	Eight				
Bore and Stroke (nominal)	4.00x3.25		4.251x3.76		
Compression Ratio	10.0:1	11.0:1	10.25:1	11.0:1	
Taxable (SAE) Horsepower	51.2		57.8		
Firing Order	1-8-4-3-6-5-7-2				
Idling Speed (RPM) (In neutral)	700 (a)	750	700 (a)	750 (a)	750
Compression Press. (PSI) @ Cranking Speed, Engine Hot	160		170		
Lubrication	Full pressure				
Power Plant Mounting	Two front and one rear, compression type				
Measurements	Fan to rear of engine block	30.64	30.78	32.14	
	Top air cleaner to bottom oil pan	26.27		27.81	
	Exhaust manifold to generator (width)	29.71		31.04	

(a) 600 for Automatic in drive

ADVERTISED ENGINE RATING

Engine	327 Cu. In.		427 Cu. In.		
	300 HP	350 HP	390 HP	400 HP	435 HP
Availability	Standard	RPO L79	RPO L36	RPO L68	RPO L71
Gross Brake HP @ RPM	300 @ 5000	350 @ 5800	390 @ 5400	400 @ 5400	435 @ 5800
Gross Torque @ RPM (lb-ft)	360 @ 3400	360 @ 3600	460 @ 3600	460 @ 3600	460 @ 4000

ENGINE SPEED AND PISTON TRAVEL

Transmission	327 Cu. In.			427 Cu. In.			
	3-Spd (a)	4-Speed		Trb/Hd (a)	4-Speed		Trb/Hd (f)
Rear Axle Ratio	3.36:1	3.36:1	3.70:1 (b)	3.08:1	3.08:1 (c)	3.36:1 (d)	3.55:1 (e)
Tire Size	F70 x 15						
Crankshaft Revolutions per Mile	2573.8		2834.2	2539.3	2359.3	2573.8	2719.3
Crankshaft RPM @ MPH	Low	108.9	108.1	103.9	97.5	99.1	94.4
	Second	64.3	80.6	77.5	1.48	73.9	70.3
	Third	42.9	62.6	59.9	39.3	57.4	54.5
	Fourth		42.9	47.2		39.3	42.9
	Reverse	112.8	111.1	106.7	81.8	101.8	96.9
Piston Travel (Ft/Mile)	1394.1		1535.2	1277.9	1479.0	1612.9	1704.1

(a) Available with 300 HP (Base) engine only

(b) Standard ratio for 350 HP (L79) engine with 2.20:1 low transmission

(c) Standard ratio for 390 HP (L36) & 400 HP (L68) engines with 2.52:1 low transmission

(d) Standard ratio for 390 HP (L36) & 400 HP (L68) engines with 2.20:1 low transmission

(e) Standard ratio for 435 HP (L71) engine with 2.20:1 low transmission

(f) Available only with 390 HP (L36) & 400 HP (L68) engines

VEHICLE PERFORMANCE FACTORS

ENGINE	BASE 327 CU.IN. 300 HP	RPO L79 327 CU.IN. 350 HP	RPO L36 427 CU.IN. 390 HP	RPO L68 427 CU.IN. 400 HP	RPO L71 427 CU.IN. 435 HP
--------	------------------------------	---------------------------------	---------------------------------	---------------------------------	---------------------------------

3-SPEED TRANSMISSION

Performance Weight (pounds)	3510				
Pounds per Gross Horsepower	11.70				
Pounds per Cu.in. Displacement	10.73				
Gross HP per Cu.in. Displacement	.917				
Power Displacement (cu.ft./mile)	243.52				
Displacement Factor (cu.ft./ton mile)	138.76				

4-SPEED TRANSMISSION

Performance Weight (pounds)	3504	3516	3682	3686	3653
Pounds per Gross Horsepower	11.68	10.05	9.44	9.21	8.40
Pounds per Cu.in. Displacement	10.72	10.75	8.62	8.63	8.55
Gross HP per Cu.in. Displacement	.917	1.070	.913	.937	1.019
Power Displacement (cu.ft./mile)	243.52	243.52	291.50	291.50	335.98
Displacement Factor (cu.ft./ton mile)	139.00	138.52	158.34	158.16	184.00

TURBO HYDRA-MATIC

Performance Weight (pounds)	3573		3751	3755	
Pounds per Gross Horsepower	11.91		9.62	9.38	
Pounds per Cu.in. Displacement	10.93		8.78	8.79	
Gross HP per Cu.in. Displacement	.917		.913	.937	
Power Displacement (cu.ft./mile)	223.23		291.50	291.50	
Displacement Factor (cu.ft./ton mile)	124.99		155.46	155.30	

GLOSSARY

Performance Weight	Curb Weight plus 300 Lb (weight of two 150 lb passengers)
Power Displacement	$\frac{\text{Crankshaft Revs/Mi} \times \text{Piston Displacement}}{2 \times 1728}$
Displacement Factor	$\frac{\text{Power Displacement}}{\text{Performance Wt (tons)}}$

ENGINE OUTPUT CURVES

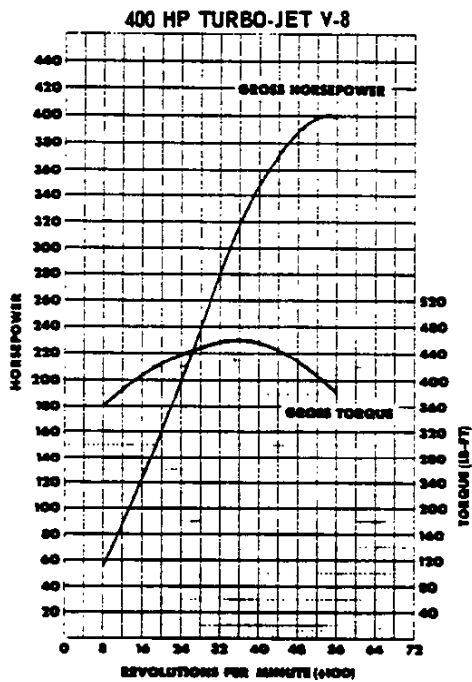
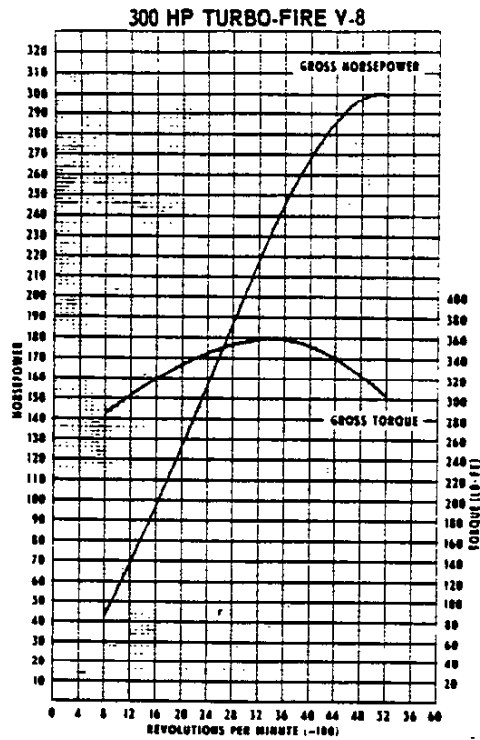

The engine output curves represent full throttle performance as obtained from dynamometer test data corrected to standard barometric pressure 29.92 inches of mercury and standard temperature of 60 degrees F.

GROSS POWER and TORQUE were obtained in a regular dynamometer test with the dynamometer exhaust system,

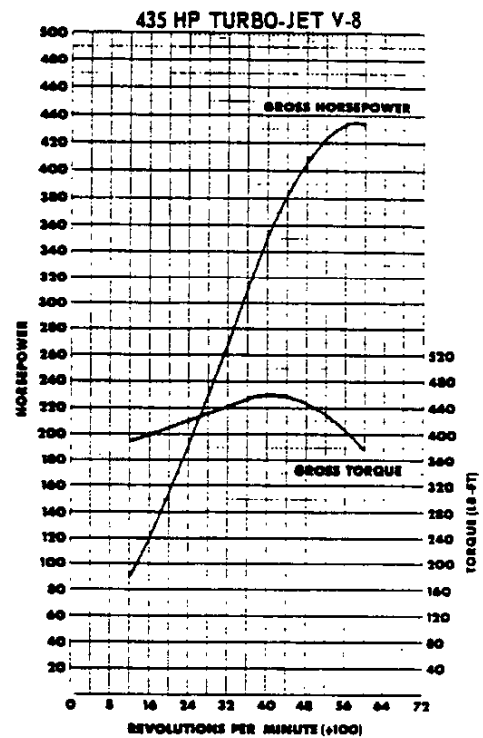

no fan, generator not charging, optimum spark advance, and optimum fuel setting.

NET POWER and TORQUE were obtained from a dynamometer test simulating actual operating conditions when the engine is in its vehicle, except the generator is not charging.

PRINCIPAL COMPONENTS

CYLINDER BLOCK

Material	-----	Cast alloy iron
Bore Diameter	-----	
V8-327 Cu.In.	-----	3.9995-4.0025
V8-427 Cu.In.	-----	4.2495-4.2525
Bore Spacing (Centerline to Centerline)	-----	
V8-327 Cu.In.	-----	4.4
V8-427 Cu.In.	-----	4.84
Number of Bulkheads	-----	5
Water Jackets	-----	Full length around each cylinder
Cylinder Numbering Arrangement (Front to Rear)	-----	
Left Bank	-----	1-3-5-7
Right Bank	-----	2-4-6-8

CYLINDER HEAD

Material	-----	High chrome cast alloy iron
Bolt Number	-----	34 (327 Cu.In.); 32 (427 Cu.In.)
Bolt Size	-----	.4375 dia.; 14 threads/inch

COMBUSTION CHAMBER VOLUME

(Total chamber volume of assembled engine with piston at top center)		
V8-327 Cu.In. (Base)	-----	4.69 Cu.In.
V8-327 Cu.In. (RPO L79)	-----	4.25 Cu.In.
V8-427 Cu.In. (RPO L36 & L68)	-----	5.94 Cu.In.
V8-427 Cu.In. (RPO L71)	-----	5.08 Cu.In.

INLET MANIFOLD

Material	-----	
V8-327 Cu.In. (Base & RPO L79)	---	Cast alloy iron
V8-427 (L36, L68 & L71)	-	Cast aluminum alloy
Heat Provision	-----	Exhaust gas crossover at carburetor mounting pad

EXHAUST MANIFOLD

Material	-----	Cast alloy iron
Type	-----	
V8-327 Cu.In.	---	Dual, 4 port, exhaust emission to a single runner with center takedown collector
V8-427 Cu.In.	-----	Dual, 4 port, extended runners from each port converging to a rear takedown collector
Outlet Diameter (Nominal)	-----	2.50

CRANKSHAFT

Material	-----	
V8-327 Cu.In. (RPO L30)	-----	Nodular iron
V8-327 (RPO L79) & 427 Cu.In.	-----	Forged steel
		Hardened journals on RPO L71
End Play	-----	
V8-327 Cu.In.	-----	.002-.006
V8-427 Cu.In.	-----	.006-.010
Counter Weights	-----	6
Crank Arm Length	-----	
V8-327 Cu.In.	-----	1.625
V8-427 Cu.In.	-----	1.88
Torsional Damper	-----	Rubber mounted inertia
Timing Gear	-----	Steel; sprocket & chain
Pulley Pitch Diameter	-----	6.64

CRANKSHAFT 327 CUBIC INCH V-8 ENGINE

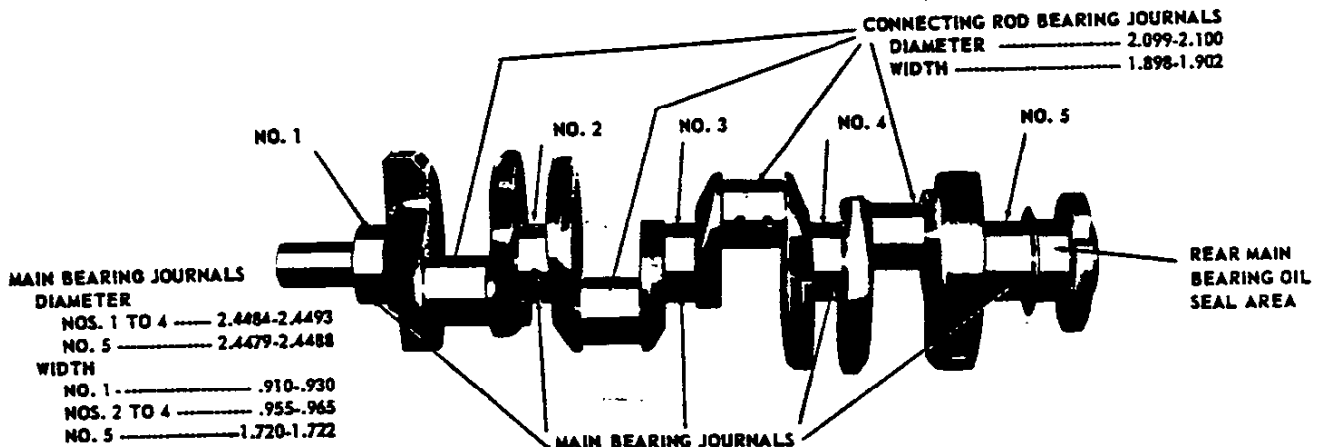

MAIN BEARINGS

Material ----- Premium aluminum except No. 5
 sintered copper nickel backed babbit
 Type ----- Precision removable
 Thrust Against Bearing No. ----- 5
 Clearance
 V8-327 Cu.In. ----- (#1) .0008-.0020;
 (#2, 3 & 4) .0008-.0024; (#5) .0015-.0031
 V8-427 Cu.In. (RPO L36 & L68) -- (#1 & 2) .0010-.0020;
 (#3 & 4) .0013-.0025; (#5) .0015-.0031
 V8-427 Cu.In. (RPO L71) ----- (#1-4) .0013-.0025;
 (#5) .0015-.0031

Dimensions	Theoretical Inner Dia.	Effective Length	Projected Area
V8-327 Cu.In.			
Bearing #1	2.4502	.752	1.8425
Bearing #2-4	2.4505	.752	1.8428
Bearing #5	2.4507	1.177	2.8844
V8-427 Cu.In. (RPO L36 & L68)			
Bearing #1-2	2.7507	.992	2.7287
Bearing #3-4	2.7505	.992	2.7285
Bearing #5	2.7506	1.2525	3.4451
V8-427 Cu.In. (RPO L71)			
Bearing #1-4	2.7505	.992	2.7285
Bearing #5	2.7506	1.2525	3.4451

CAMSHAFT

Material ----- Cast alloy iron
 Drive ----- Sprocket & chain; steel
 Lobe Lift
 V8-327 Cu.In. (Base) ----- .2600 Inlet; .2733 Exhaust
 V8-327 Cu.In. (RPO L79) ----- .2981 Inlet & Exhaust
 V8-427 Cu.In. (RPO L36 & L68) ----- .2714 Inlet;
 .2824 Exhaust
 V8-427 Cu.In. (RPO L71) ----- .3057 Inlet & Exhaust
 Bearings ----- 5; steel backed babbit

VALVE TRAIN

Type ----- Individually mounted
 overhead rocker arms, push rod actuated
 Lifters ----- Hydraulic
 V8-427 Cu.In. (RPO L71) - Mechanical
 Push Rods
 Type ----- Hollow steel
 Ends
 V8-327 (Base) ----- Hardened
 V8-327 Cu.In. (RPO L79) ----- Hardened steel
 insert on rocker arm ends
 V8-427 Cu.In. ----- Hardened steel inserts
 Rocker Arms
 Material ----- Stamped steel
 Ratio
 V8-327 Cu.In. ----- 1.50:1
 V8-427 Cu.In. ----- 1.70:1

VALVE SPRINGS

Diameter (I.D.)
 V8-327 Cu.In. ----- .868-.884
 V8-427 Cu.In. ----- 1.082-1.098
 Installed Length (lb. @ in.)
 Valves Closed
 V8-327 Cu.In. ----- 76-84 @ 1.70
 V8-427 Cu.In. ----- 94-106 @ 1.88
 Valves Opened
 V8-327 Cu.In. ----- 194-206 @ 1.25
 V8-427 Cu.In. ----- 303-327 @ 1.38
 Free Length
 V8-327 Cu.In. ----- 2.03
 V8-427 Cu.In. ----- 2.09
 Valve Spring Damper
 V8-327 Cu.In. ----- Flat steel, 4 coils
 V8-427 Cu.In. ----- Flat steel, 3,62 coils

**CAMSHAFT
 327 CUBIC INCH V-8 ENGINE**

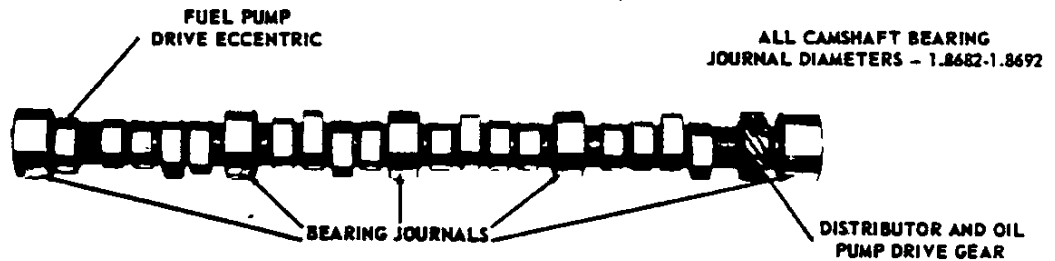

PRINCIPAL COMPONENTS—Cont'd.

VALVES - INLET

Material -----	Alloy steel
Coating	
V8-327 Cu.In. (RPO L30) -----	None
V8-327 (RPO L79) & 427 Cu.In. -----	Face & head aluminized, also chrome flash stem on V8-327 (RPO L79) & 427 (RPO)L71 Cu.In.
Valve Guide Inserts (V8-427) -----	Cast alloy iron

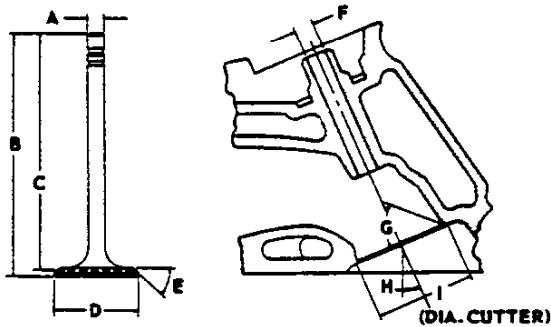

A - Stem Diameter	
V8-327 Cu.In. -----	.3410-.3417
V8-427 Cu.In. -----	.3715-.3722
B - Overall Length	
V8-327 Cu.In. -----	4.870-4.889
V8-427 Cu.In. (RPO L36 & L68) -----	5.215-5.235
V8-427 Cu.In. (RPO L71) -----	5.204-5.224
C - Gage Length	
V8-327 Cu.In. -----	4.785-4.795
V8-427 Cu.In. -----	5.115-5.125
D - Overall Head Diameter	
V8-327 Cu.In. (Base) -----	1.935-1.945
V8-327 Cu.In. (RPO L79) -----	2.017-2.023
V8-427 Cu.In. (RPO L36 & L68) -----	2.060-2.070
V8-427 Cu.In. (RPO L72) -----	2.185-2.195
E - Angle of Face -----	45°
F - Guide Diameter	
V8-327 Cu.In. -----	.3427-.3437
V8-427 Cu.In. -----	.3732-.3742
G - Angle of Seat -----	46°
H - Valve Angle	
V8-327 Cu.In. -----	23°
V8-427 Cu.In. -----	4°
I - Valve Seat (Cutter) Diameter	
V8-327 Cu.In. (Base) -----	1.990-2.010
V8-327 Cu.In. (RPO L79) -----	2.020
V8-427 Cu.In. -----	2.150

VALVE - EXHAUST

Material -----	High alloy steel
Coating	
V8-327 Cu.In. -----	Aluminum face
V8-427 Cu.In. -----	Face & head aluminized, also chrome flash stem on V8-327 (RPO L79) & 427 (RPO L71) Cu.In.
Valve Guide Inserts (V8-427) -----	Cast alloy iron

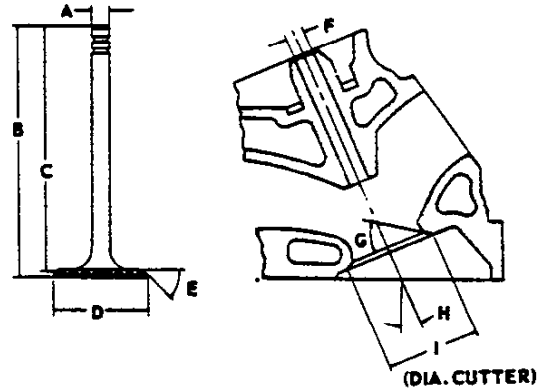

A - Stem Diameter	
V8-327 Cu.In. -----	.3410-.3417
V8-427 Cu.In. -----	.3715-.3720
B - Overall Length	
V8-327 Cu.In. (Base) -----	4.913-4.933
V8-327 Cu.In. (RPO L79) -----	4.891-4.910
V8-427 Cu.In. -----	5.345-5.365
C - Gage Length	
V8-327 Cu.In. -----	4.781-4.791
V8-427 Cu.In. -----	5.235-5.245
D - Overall Head Diameter	
V8-327 Cu.In. (Base) -----	1.495-1.505
V8-327 Cu.In. (RPO L79) -----	1.595-1.605
V8-427 Cu.In. -----	1.715-1.725
E - Angle of Face -----	45°
F - Guide Diameter	
V8-327 Cu.In. -----	.3427-.3437
V8-427 Cu.In. -----	.3732-.3742
G - Angle of Seat -----	46°
H - Valve Angle	
V8-327 Cu.In. -----	23°
V8-427 Cu.In. -----	4°
I - Valve Seat (Cutter) Diameter	
V8-327 Cu.In. (Base) -----	1.550-1.570
V8-327 Cu.In. (RPO L79) -----	1.600
V8-427 Cu.In. -----	1.625

PISTONS

Material	
V8-327 Cu.In. (Base)	Cast aluminum alloy
V8-327 Cu.In. (RPO L79)	Aluminum impact extruded
V8-427 Cu.In. (RPO L36 & L68)	Cast aluminum alloy
V8-427 Cu.In. (RPO L71)	Aluminum impact extruded
Head Type	
V8-327 Cu.In. (Base)	Flat, notched
V8-327 Cu.In. (RPO L79)	Domed
V8-427 Cu.In.	Domed
Skirt Type	
V8-327 Cu.In.	Slipper
Top Land Clearance	
V8-327 Cu.In. (Base)	.0365-.0455
V8-427 Cu.In. (RPO L36 & L68)	.0305-.0375
V8-427 Cu.In. (RPO L71)	.0265-.0335
Skirt Clearance	
V8-327 Cu.In. (Base)	.0005-.0011
V8-327 Cu.In. (RPO L79)	.0024-.0030
V8-427 Cu.In. (RPO L36 & L68)	.0012-.0018
V8-427 Cu.In. (RPO L71)	.0040-.0046
Compression Ring Groove Depth	
V8-327 Cu.In.	.2217-.2283
V8-427 Cu.In.	.2348-.2413
Oil Ring Groove Depth	
V8-327 Cu.In.	.2038-.2103
V8-427 Cu.In. (RPO L36 & L68)	.2183-.2248
V8-427 Cu.In. (RPO L71)	.2133-.2148
Pin Bore Offset	
V8-327 (Base) & 427 (RPO L36 & L68)	.055-.065
V8-327 (RPO L79) & 427 (RPO L71)	On center
Compression Height	
V8-327 Cu.In. (Base)	1.674-1.676
V8-327 Cu.In. (RPO L79)	1.673-1.677
V8-427 Cu.In. (RPO L36 & L68)	1.908-1.912
V8-427 Cu.In. (RPO L71)	2.068-2.072

PISTON PINS

Material	Chromium steel
Length	
V8-327 Cu.In.	2.990-3.010
V8-427 Cu.In.	2.930-2.950
Diameter	
V8-327 Cu.In.	.9270-.9273
V8-427 Cu.In.	.9895-.9898
Clearance in Piston	
V8-327 Cu.In. (Base)	.00015-.00025
V8-327 Cu.In. (RPO L79)	.00045-.00055
V8-427 Cu.In. (RPO L36 & L68)	.00025-.00035
V8-427 Cu.In. (RPO L71)	.00030-.00040
Pin Mounting	Locked in rod by shrink fit

VALVE LIFT

V8-327 Cu.In. (Base)	.3900 Inlet & .4100 Exhaust
V8-327 Cu.In. (RPO L79)	.4472 Inlet & Exhaust
V8-427 Cu.In. (RPO L36 & L68)	.4614 Inlet; .4800 Exhaust
V8-427 Cu.In. (RPO L71)	.5197 Inlet & Exhaust

VALVE TIMING (Crankshaft Degrees)

V8-327 Cu.In. - Base	Excluding Ramps	Including Ramps
Inlet Valve (Zero lash)		
Opens - BTC	28°	38°
Closes - ABC	72°	92°
Duration	280°	310°
Exhaust Valve (Zero lash)		
Opens - BBC	78°	88°
Closes - ATC	30°	52°
Duration	288°	320°

V8-327 Cu.In. - RPO L79	Excluding Ramps	Including Ramps
Inlet Valve (Zero lash)		
Opens - BTC	40°	54°
Closes - ABC	86°	108°
Duration	306°	342°
Exhaust Valve (Zero lash)		
Opens - BBC	88°	102°
Closes - ATC	38°	60°
Duration	306°	342°

V8-427 Cu.In. - RPO L36 & L68	Excluding Ramps	Including Ramps
Inlet Valve (Zero lash)		
Opens - BTC	40°	56°
Closes - ABC	80°	114°
Duration	300°	350°
Exhaust Valve (Zero lash)		
Opens - BBC	88°	110°
Closes - ATC	32°	62°
Duration	300°	352°

V8-427 Cu.In. - RPO L71	Excluding Ramps	Including Ramps
Inlet Valve (opens with .024 lash)		
Opens - BTC		44°
Closes - ABC		92°
Duration		316°
Exhaust Valve (closes with .028 lash)		
Opens - BBC		86°
Closes - ATC		36°
Duration		302°

PRINCIPAL COMPONENTS—Cont'd.

COMPRESSION RING - UPPER

Material	-----	Cast alloy iron
Type	-----	Straight edge inside of ring
Face	-----	Barrel
Coating		
V8-327 Cu.in. (Base)	-----	Chrome plate
V8-327 Cu.in. (RPO L79)	-----	Molybdenum inlay
V8-427 Cu.in.	-----	Molybdenum inlay
Width		
V8-327 Cu.in. (Base)	-----	.0775-.0780
V8-327 Cu.in. (RPO L79)	-----	.0770-.0775
V8-427 Cu.in.	-----	.0770-.0775
Wall Thickness		
V8-327 Cu.in.	-----	.190-.200
V8-427 Cu.in.	-----	.202-.212
Gap	-----	.010-.020

COMPRESSION RINGS - LOWER

Material	-----	Cast alloy iron
Type	-----	Inside bevel (top of ring 30 degrees to piston vertical axis for V8-327; 28°-52° for V8-427)
Face	-----	Tapered
Coating		
V8-327 Cu.in. (Base)	-----	Wear resistant
V8-327 Cu.in. (RPO L79)	-----	Chrome plate
V8-427 Cu.in. (RPO L36 & L68)	-----	Wear resistant
V8-427 Cu.in. (RPO L71)	-----	Chrome plate
Width		
V8-327 Cu.in. (Base)	-----	.0770-.0775
V8-327 Cu.in. (RPO L79)	-----	.0775-.0780
V8-427 Cu.in.	-----	.0770-.0775
Wall Thickness		
V8-327 Cu.in.	-----	.190-.200
V8-427 Cu.in.	-----	.202-.212
Gap		
V8-327 Cu.in. (Base)	-----	.013-.025
V8-327 Cu.in. (RPO L79)	-----	.013-.023
V8-427 Cu.in.	-----	.010-.020

OIL CONTROL RINGS

Type	-----	Multi-piece (two rails and one spacer)
Material		
Rails	-----	Steel
Spacer	-----	Alloy steel
Width (assembled)		
V8-327 Cu.in.	-----	.1870-.1890
V8-427 Cu.in.	-----	.1870-.1890
Wall Thickness		
V8-327 Cu.in.	-----	.150-.156
V8-427 Cu.in.	-----	.137-.143
Gap		
V8-327 Cu.in.	-----	.015-.055
V8-427 Cu.in.	-----	.010-.030
Rail Coatings	-----	Chrome plated

CONNECTING RODS

Material	-----	Drop forged steel
V8-427 (RPO L71)	-----	High alloy steel
Length (center to center)		
V8-327 Cu.in.	-----	5.699-5.701
V8-427 Cu.in.	-----	6.130-6.140

CONNECTING ROD BEARINGS

Material	-----	Premium aluminum
Type	-----	Precision removable
Clearance		
V8-327 Cu.in.	-----	.0007-.0027
V8-427 Cu.in. (RPO L36 & L68)	-----	.0009-.0029
V8-427 Cu.in. (RPO L71)	-----	.0014-.0034
Theoretical I. D.		
V8-327 Cu.in.	-----	2.1017
V8-427 Cu.in. (RPO L36 & L68)	-----	2.2014
V8-427 Cu.in. (RPO L71)	-----	2.2019
Effective Length		
V8-327 Cu.in.	-----	.797
V8-427 Cu.in.	-----	.857
End Play		
V8-327 Cu.in.	-----	.009-.013
V8-427 Cu.in.	-----	.016-.020

FUEL—EXHAUST AND VENTILATION SYSTEM

FUEL SYSTEM

FUEL TANK

Capacity (Gal) ----- 20 (approximately)
 Location ----- In body cavity at rear of deck area
 Filler Location ----- Center of rear deck lid

FUEL FILTERS, DUAL

In Fuel Tank ----- Mesh strainer
 Carburetor Inlet ----- Paper

FUEL PUMP

Type ----- Diaphragm
 Drive ----- Camshaft eccentric
 Location ----- Lower right front of engine
 Pressure Range ----- 5.00-6.50 PSI

AIR CLEANER

Type
 V8-327 & 427 (RPO L36) ----- Full circle intake,
 chrome plated
 V8-427 (RPO L68 & L71) ----- Triangular shaped,
 chrome plated
 Filter Element ----- Oil-wetted paper
 V8-427 (RPO L68 & L71) ----- Polyurethane

CARBURETORS

Make & Type
 V8-327 Cu.In. ----- Rochester, Quadrajet
 V8-427 Cu.In. (RPO L36) ----- Rochester, Quadrajet
 V8-427 Cu.In. (RPO L68 & L71) ----- Holley, 3 x 2
 SAE Flange Size ----- 1.50
 Throttle Bore
 V8-327 & 427 Cu.In. (RPO L36)
 Primary ----- 1.38
 Secondary ----- 2.25
 V8-427 Cu.In. (RPO L68 & L71)
 Primary (No. 1) ----- 1.50
 Secondary (No. 2 & 3) ----- 1.75
 Venturi Diameter
 V8-327 & 427 Cu.In. (RPO L36)
 Primary ----- 1.09
 Secondary ----- Air valve
 V8-427 Cu.In. (RPO L68 & L71)
 Primary (No. 1) ----- 1.188
 Secondary (No. 2 & 3) ----- 1.375
 Secondary Throttle Actuation ----- By linkage
 approximately when primary valves are
 opened half between closed and open

CHOKE

Type ----- Automatic

EXHAUST AND VENTILATION SYSTEM

EXHAUST SYSTEM

Type ----- Dual with no resonators

MUFFLERS

Type ----- Dual, reverse flow
 Construction ----- Heads and body joined
 by rolled lock seam construction
 Shell
 Right Hand ----- .036 stainless steel
 Left Hand ----- .036 sheet steel aluminum coating
 Wrap ----- .030 indented asbestos sheet
 Cover ----- .018 sheet steel aluminum coating
 Heads
 Right Hand ----- .048 stainless steel
 Left Hand ----- .048 sheet steel aluminum coating
 Baffles
 Right Hand ----- 4; #1 & #4, .036 stainless steel;
 #2 & #3, .036 sheet steel aluminum coating
 Left Hand ----- 4; .036 sheet steel aluminum coating
 Length, Body ----- 17.00
 Width (I.D.) ----- 9.25
 Height (I.D.) ----- 5.00

EXHAUST PIPES

Type ----- Two pieces; front and rear assemblies
 Material ----- Seamless steel tubing
 Dimensions (O.D.) ----- 2.50
 Wall Thickness
 Front Pipes ----- .072-.092
 Rear Pipes ----- .084-.104 laminated

TAIL PIPES

Material ----- Stainless steel
 Dimensions (O.D.) ----- 2.62
 Wall Thickness ----- .062-.072

ENGINE VENTILATION

Type ----- Closed-positive

AIR INJECTION REACTOR EQUIPMENT (AIE)

Type ----- Air injected
 into exhaust ports crankshaft driven pump

COOLING SYSTEM

GENERAL

Type	-----	Liquid, pressurized
V8-327 Cu.,In. (Base)	-----	Internal by-pass
V8-327 Cu.,In. (RPO L79)	-----	External by-pass
V8-427 Cu.,In.	-----	External by-pass
Capacity (with Hearer)		
V8-327 Cu.,In.	-----	15 Qts
V8-427 Cu.,In.	-----	22 Qts

RADIATOR

Type		
V8-327 Cu.,In.	-----	Aluminum, cross-flow
V8-427 Cu.,In.	-----	Copper-brass, cross-flow
Core Constant		
Distance between Fins		
V8-327 Cu.,In.	-----	.18
V8-427 Cu.,In.	-----	.16
Distance between Tubes	-----	.35
Thickness of Core		
V8-327 Cu.,In.	-----	2.88
V8-427 Cu.,In.	-----	2.70
Frontal Area (Sq. In.)		
V8-327 Cu.,In.	-----	315
V8-427 Cu.,In.	-----	382

SURGE TANK (327 Cu.,In. Only)

Location	-----	Right side engine compartment connected by hoses to top of radiator
Capacity	-----	2.3 Qts
Fill Requirements	-----	Half full when weather is cold

RADIATOR CAP RELIEF VALVE

Opens at	-----	Approximately 15 PSI
----------	-------	----------------------

FAN

Number of Blades	-----	5, staggered
Diameter		
V8-327 Cu.,In.	-----	17.12
V8-427 Cu.,In.	-----	17.50
Fan Pulley Pitch Diameter	-----	7.00
Drive		
Type	-----	Thermomodulated fluid coupling
Performance at 4000 RPM Input	---	At 135°-155°F fan speed 3200 to 3500 RPM; at 120°F and below, fan speed 800-1800 RPM

THERMOSTAT

Type	-----	Pellet
Begins to Open at	-----	192°-198°F
Fully Opened at	-----	217°F

RADIATOR HOSE

Outlet, Lower (Radiator to Water Pump)		
V8-327 Cu.,In.	-----	1.75 I. D.
V8-427 Cu.,In.	-----	1.88 I. D.
Inlet, Upper (Thermostat Housing to Radiator)		
V8-327 Cu.,In.	-----	1.56 I. D.
V8-427 Cu.,In.	-----	1.50 I. D.

BY-PASS THERMOSTAT HOSE

V8-327 Cu.,In. (RPO L79)	-----	.725-.765 I.D.
V8-427 Cu.,In.	-----	.725-.765 I.D.

BELTS; CRANKSHAFT, FAN AND GENERATOR

Number Used		
V8-327 Cu.,In. (Base)	-----	One
V8-327 Cu.,In. (RPO L79)	-----	Two
V8-427 Cu.,In.	-----	Two
Angle of "V"	-----	38°-42°
Pitch Line		
Fan, Generator and Water Pump Belt		
V8-327 Cu.,In. (Base)	-----	53.25
V8-327 Cu.,In. (RPO L79)	-----	54.00
V8-427 Cu.,In.	-----	56.00
Fan and Water Pump Belt		
V8-327 Cu.,In. (RPO L79)	-----	34.40
V8-427 Cu.,In.	-----	34.40
Width	-----	.380

WATER PUMP

Type	-----	Centrifugal
Capacity (GPM @ Engine RPM)		
V8-327 Cu.,In.	-----	57 @ 4400
V8-427 Cu.,In.	-----	82 @ 5200
Bearing	-----	Permanently lubricated double row ball
Drive	-----	Fan belt
Ratio (Pump to Engine RPM)	-----	.949:1

DRAIN LOCATIONS AND TYPE

Radiator	-----	Left hand, rear lower face
Engine Block	-----	Plug; right and left center

ELECTRICAL SYSTEM

SUPPLY SYSTEM

BATTERY

Voltage ----- 12
 Cranking Power @ 0° F ----- 3250 watts
 Total Number of Plates ----- 78
 Number of Cells ----- 6
 Terminal Grounded ----- Negative
 Location ----- In passenger compartment
 behind driver

GENERATOR

Type ----- Diode rectified
 Rating
 Amps ----- 9-37
 Volts ----- 10-15
 Drive ----- By fan belt
 Pulley Pitch Diameter ----- 2.70
 Ratio (Gen to Engine Speed) ----- 2.46:1

REGULATOR

Type ----- Two unit; vibrator
 Voltage Regulator
 Voltage ----- 13.8-14.8 @ 85° F
 Field Relay (Combination Light & Field Relay)
 Closing Voltage ----- 1-3 Volts @ 80° F
 Location ----- Right side front engine compartment

STARTING SYSTEM

STARTING MOTOR

Rotation (Drive End View) ----- Clockwise
 Test Conditions ----- Engine at operating temperature
 No Load Test
 Amps ----- 65-100 (327); 70-99 (427)
 Volts ----- 10.6
 RPM ----- 3600-5100 (327); 7800-12000 (427)

Motor Drive

Engagement ----- Solenoid
 Pinion Meshes at ----- Rear
 Pinion Tooth No. ----- 9
 Flywheel Tooth No. ----- 153; V8-427 -- 168
 Mounting ----- Bolted to clutch housing

IGNITION SYSTEM

DISTRIBUTORS ----- Refer to chart below

COIL

Type ----- 12 Volt
 Amperes Drawn
 Engine Stopped ----- 4.0
 Engine Idling ----- 1.8

SPARK PLUGS

Make & Type
 V8-327 Cu.In. ----- AC44
 V8-427 Cu.In. ----- AC43N
 Thread Size (mm) ----- 14
 Gap ----- .033-.038
 Torque ----- 25 lb ft

CABLE

----- Linen core impregnated
 with electrical conducting material and
 insulation of rubber with neoprene jacket

DISTRIBUTORS	V-8 327 Cu.In. Base 300 HP	V-8 327 Cu.In. RPO L79 350 HP	V-8 427 Cu.In. RPO L36 390 HP	V-8 427 Cu.In. RPO L68 400 HP	V-8 427 Cu.In. RPO L71 435 HP
Model	1111194	1111438	1111293		1111296
Type	Single Breaker				
Cam Angle	28° - 32°				Transistorized
Breaker Gap	.019 (new)				Magnetic Pulse
Breaker Arm Tension	19 - 23 oz		28 - 32 oz		
Centrifugal Advance Begins (RPM)	900	950	900		900
Max Degrees @ RPM	30 @ 5100	30 @ 4700	32 @ 5000		30 @ 3800
Vacuum Advance Begins (In. Hg)	6.00	6.00	7.00		8.00
Max Degrees @ In. Hg	15 @ 12	15 @ 15.5	12 @ 12		15 @ 15.5
Timing (Initial Design Setting)	4 BTC @	4 BTC @	4 BTC @	4 BTC @	4 BTC @
Cranksaft Degrees @ RPM (with vacuum spark line disconnected)	700 manual 600 auto	750 manual only	700 manual 600 auto	750 manual 600 auto	750 manual only
Timing Mark Location	Torsional Damper				

CLUTCHES AND TRANSMISSIONS

CLUTCHES

Engine	Type	V-8 327 Cubic Inch		V-8 427 Cubic Inch		
	Availability	Regular Production	RPO L79	RPO L36 & L68	RPO L72	
Clutch for		3-Speed & 4-Speed	4-Speed	4-Speed		
Type		Single dry disc, centrifugal				
Clutch cover & pressure plate	Eff. plate load, lbs.	2100-2300	2300-2600	2450-2750	2600-2800	
	Press. plate matl.	Nodular iron				
	Clutch spring type	Circular plate diaphragm, bent finger design				
	Clutch spring matl.	Heat treated spring steel				
Driven plate	Type	Single disc with two friction surfaces				
	Cushions	Flat spring steel between friction rings				
	Dampers	10 coil springs (5 sets of two)				
	Friction rings	OD	10.34		11.00	
		ID	6.50		6.50	
		Total area sq. in.	101.54		123.70	
		Material	Woven type asbestos			
Flywheel	Ring gear	Material	Heat treated HR steel			
		No. of teeth	153		168	
		PD	12.75		14.00	
		Attachment	Shrink fit			
Bearings	Release	Type	Single row ball			
		Lubrication	None, prepacked			
	Pilot	Type	Bronze bushing			
		Lubrication	None, sintered and oil impregnated			
Controls	Clutch fork	Drop forged steel, pivot mounted on ball				
	Pedal mounting	Pendulum, from brace on dash				
	Lubrication	Crossover shaft				
Clutch housing material		Aluminum alloy				

3-SPEED AND 4-SPEED TRANSMISSIONS

Transmission Type		3-Speed	4-Speed RPO M20		4-Speed RPO M21		
Engine	Type	V8-327 Cu. In.	V8-327 Cu. In.	V8-427 Cu. In.	V8-327 Cu. In.	V8-327 Cu. In.	
Application	Availability	Standard	Standard	RPO L79	L36, L68	RPO L79	
Case material		Cast iron	Aluminum				
Gear Shift	Type	Remote					
	Control	Lever					
	Location	Floor, mounted between seats					
Gears	Type	Helical					
	Material	Forged steel, hardened					
	Synchronization	All forward gears					
	Constant mesh gear	All gears	All forward gears				
	Sliding gears		None	Reverse			
		Ratio	First	2.54	2.52		2.20
		Second	1.50	1.88		1.64	
		Third	1.00	1.47		1.27	
	Fourth	1.00	1.00		1.00		
	Reverse	2.63	2.59		2.26		
Lubricant	Type	Meeting Military Specification MIL-L-2105-B					
	Capacity (qt.)	3					
Extension	Material	Cast iron	Aluminum				
	Oil seal	Steel encased double seal of spring loaded rubber or felt					

TRANSMISSIONS—Cont'd.

TURBO HYDRA-MATIC TRANSMISSION (RPO M40)

GENERAL DATA

Type ----- Three element automatic hydraulic torque converter with a compound planetary gear set that produces three forward speeds and reverse

Selector Lever

Location ----- Floor mounted

Operation ----- Actuates automatic controls by a hydraulic system from a pressurized gear type pump

Quadrant Pattern Six positions: P-R-N-3-2-1

External Control Connections

Manual Linkage ----- Selects desired operating range by means of selector lever

Vacuum Modulator ----- Senses change in the torque input to the transmission and assures smooth shifts

Detent Solenoid ----- Actuated by electric switch or the carburetor causing the transmission to downshift under full throttle conditions at car speeds below 70 miles per hour

Parking Lock

Type ----- Locking pawl

Operation ----- Applied by selector lever through manual linkage

Method of Cooling ----- Water

TORQUE CONVERTER

Driving Member (Pump) ----- Multivane type, sheet metal blade, spot welded to steel pump housing that is an integral part of the converter housing

Driven Member (Turbine) ----- Steel axial flowblades assembled between inner and outer steel shells

Stator Assembly ----- Aluminum multivane type blades mounted on a one way roller clutch

Stall Ratio ----- 2.04

Stall Speed (RPM) ----- 2100

Diameter (Nominal) ----- 12.83

CLUTCHES

Type ----- Three, multiple disk

Material

Drive plates ----- Waved steel with beaded organic facings

Driven plates ----- Flat steel

Forward clutch ----- Five each drive and driven plates

Direct clutch ----- Five each drive and driven plates

Intermediate clutch ----- Three each drive and driven plates

Release spring ----- Radial row steel coil

TRANSMISSIONS —Cont'd.

PLANETARY GEAR UNIT

Front ---- Reaction carrier Assy ----- Four
 steel pinion gears

Rear ---- Output carrier Assy ----- Four
 steel pinion gears

Gear Ratios
 "3" ----- 2.48:1, 1.48:1, 1.00:1
 "2" ----- 2.48:1, 1.48:1
 "1" ----- 2.48:1
 R (Reverse) ----- 2.08:1

Front Band
 Type ----- One, circular steel with organic lining
 Function ----- Provides engine braking in 2nd gear with selector lever in "2" and "1" range

Rear Band
 Type ----- Double wrap circular steel with organic lining
 Function ----- Provides engine braking Lo range 1st gear; also in reverse range the band holds the reaction carrier to apply reverse gear ratio

Servo units ----- Piston with release spring and inner cushion spring that activates the bands

LUBRICANT

Type ----- A suffix A
 Capacity ----- 22 pcs
 Refill ----- 8 pcs
 Oil cooler ----- Integral with radiator assembly and connected to transmission by inlet and outlet pipes

HYDRAULIC SYSTEM

Oil pressure pump ----- Supplies hydraulic pressure by gear type pump which is engine driven

Pump pressure (450 RPM input @ 25 in. Hg vacuum)
 Park ----- 70 PSI
 Neutral ----- 70 PSI
 "3" (First, second, third) ----- 70 PSI
 "2" (First, second) ----- 150 PSI
 "1" ----- 150 PSI
 Reverse ----- 107.5 PSI

Valves
 Type ----- Steel spool
 Manual ----- Establishes range at transmission operation

Pressure regulator ----- Controls main line pressure

Shift (1-2) ----- Controls oil pressure for trans. shift from 1-2 or 2-1

Shift (2-3) ----- Controls oil pressure for trans. shift from 2-3 or 3-2

Modulator ----- Regulates line pressure with modulator oil pressure that varies with torque to transmission

Accumulator ----- To obtain greater flexibility in attaining desired shift curve for various engine requirements

Governor
 Type ----- Cross-axis centrifugal
 Operation ----- Regulates a pressure proportional to car speed which acts upon the (1-2) (2-3) shift valves and modulator valve

TORQUE MULTIPLICATION

"3" (maximum) ----- 5.06:1 to 1.00
 "2" ----- 5.06:1 to 1.48
 "1" ----- 5.06:1 to 2.48
 Reverse ----- 4.24:1 to 2.08



AMA Specifications—Passenger Car

The information contained herein is prepared, distributed by, and is solely the responsibility of the automobile manufacturing company to whose products it relates. Questions concerning these specifications should be directed to the manufacturer whose address is shown below. This uniform specification form was developed by the automobile manufacturing companies under the auspices of the Automobile Manufacturers Association.

MANUFACTURER Chevrolet Motor Division Owner Relations Department		CAR NAME CORVETTE	
MAILING ADDRESS 1077 Argonaut "A" G. M. Bldg. Detroit, Michigan 48202		MODEL YEAR 1968	ISSUED: 10-15-67 REVISED (●)

NOTES:

1. The Specifications herein are those in effect at date of compilation and are subject to change without notice by the manufacturer.
2. UNLESS OTHERWISE INDICATED:
 - a. Specifications apply to standard models without optional equipment. Significant deviations are noted.
 - b. Nominal design dimensions are used throughout these specifications.

TABLE OF CONTENTS

Car & Body Dimensions	1, 2	Drive Units	14	Suspensions	
Engine - Mechanical	4	Brakes	18, 19	Weights	
Electrical	12	Steering	20	Index	

BODY - TYPES AND STYLE NAMES -

Body type, number of passenger & style names; use manufacturer's code for series & body style.

	<u>327 Cu. In.</u>	<u>427 Cu. In.</u>
	V8-300HP V8-350 HP	V8-390HP V8-400HP V8-430HP
	Standard Opt(L79)	Opt(L79) Opt(L68) Opt(L71)
2-Door Sport Coupe, 2-Pass.		19437
2-Door Convertible, 2-Pass.		19467

AMA Specifications—Passenger Car

MAKE OF CAR CORVETTE MODEL YEAR 1968 DATE ISSUED 10/15/67 REVISED (e)

CAR AND BODY DIMENSIONS

See Pages 25, 26 for SAE Dimension Definitions

(All dimensions in inches unless otherwise indicated)

All dimensions to ground are for comparative purposes only and are shown with vehicle load of two passengers in front and three in rear, except where otherwise noted.

MODEL	19400	SAE Ref. No.	SPORT COUPE	CONVERTIBLE	
				SOFT TOP	HARDTOP
WIDTH					
Track - Front		W101		58.3	
Track - Rear		W102		59.0	
Maximum overall car width		W103		69.2	
Body width at No. 2 pillar		W117			
LENGTH					
Body "O" to front of dash		L 30			
Wheelbase		L101		98.0	
Overall car length		L103		182.1	
Overhang - front		L104		40.2	
Overhang - rear		L105		43.9	
Body upper structure length		L123	54.7		
Body "O" line to C of rear wheel		L127		72.0	
Body "O" line to w/s cowl point		L130		11.6	
HEIGHT					
Overall height		H101	47.8		
Cowl height		H114		26.6	
Deck height		H138			
Rocker panel - front	To ground			7.6	
	From front wheel C	H112			
Rocker panel - rear	To ground			7.6	
	From rear wheel C	H111			
Windshield slope angle		H122		57	
GROUND CLEARANCE					
Bumper to ground - front		H102		9.2	
Bumper to ground - rear		H104		12.3	
Angle of approach		H106		22	
Angle of departure		H107		21	
Romp breakover angle		H147		22	
Min. running clearance (Specify)		H156		4.9 (Exhaust to ground)	

AMA Specifications—Passenger Car

MAKE OF CAR CORVETTE MODEL YEAR 1968 DATE ISSUED 10/15/67 REVISED (0)

CAR AND BODY DIMENSIONS

See Pages 25, 26 for SAE Dimension Definitions
(All dimensions in inches unless otherwise indicated)

MODEL	19400	SAE Ref. No.	SPORT COUPE	CONVERTIBLE	
				SOFT TOP	HARDTOP
FRONT COMPARTMENT					
Effective head room	H61	36.2	37.1	36.0	
Max. eff. leg room - accelerator	L34		43.0		
H Point to Heel point	H30		6.5		
H Point travel	L17		4.5		
Shoulder room	W 3		46.9		
Hip room	W 5		48.8		
Upper body opening to ground	H50		43.6		
REAR COMPARTMENT					
H Point couple distance	L50		--		
Effective head room	H63		--		
Min. effective leg room	L51		--		
H Point to Heel point	H31		--		
Min. knee room	L48		--		
Rear Compartment room	L 3		--		
Shoulder room	W 4		--		
Hip room	W 6		--		
Upper body opening to ground	H51		--		
LUGGAGE COMPARTMENT					
Usable luggage capacity	V 1				
Liftover height	H195				
Position of spare tire storage					
Method of holding lid open					
STATION WAGON - THIRD SEAT					
Shoulder Room	W85				
Hip room	W86				
Effective leg room	L86				NOT AVAILABLE
Effective head room	H86				
Seat facing direction					
STATION WAGON - CARGO SPACE					
Cargo length at floor - front seat	L202				
Cargo length at belt - front seat	L204				
Cargo width - wheelbase	W201				
Opening width at belt	W204				NOT AVAILABLE
Maximum cargo height	H201				
Rear opening height	H202				
Cargo volume index (cu. ft.) W4 x L204 x H201 1778	V2				

AMA Specifications—Passenger Car

MAKE OF CAR CORVETTE MODEL YEAR 1968 DATE ISSUED 10/15/67 REVISED (e)

POWER TEAMS

(Indicate whether standard or optional)

A B C D

MODEL AVAILABILITY	ENGINE					TRANSMISSION	AXLE RATIO ** (Std. first) (Indicate A/C ratio) *				
	Displ. cu. in.	Carburetor	Compr. Ratio	BHP RPM	Torque RPM						
ALL MODELS	327 Std.	One; 4-Bbl	10.0:1	300 @ 5000	360 @ 3400	2-Speed (2.54:1 low)	Base	3.36	3.08	--	--
						& 4-Speed* (2.52:1 low)	A/C	3.36	3.08		
						Turbo*	Base	3.08	--	--	--
						Hyd-Mtc.	A/C	3.08	--	--	--
						4-Speed* (2.52:1 low)	Base	3.36	--	3.55	--
						A/C	3.36	--	3.55	--	
	327 Opt. (L79)	One; 4-Bbl	11.0:1	350 @ 5800	360 @ 3600	4-Speed* (2.52:1 low)	Base	3.36	--	3.55	--
						A/C	3.36	--	3.55	--	
						4-Speed* (2.20:1 low)	Base	3.70	--	4.11	--
						A/C	3.70	--	4.11	--	
						4-Speed* (2.52:1 low)	Base	3.08	--	3.36	
						A/C	3.08	--	3.36	--	
	427 Opt. (L36)	One; 4-Bbl	10.25:1	390 @ 5400	460 @ 3600	4-Speed* (2.52:1 low)	Base	3.36	3.08	3.55	3.70
						A/C	3.36	3.08	3.55	3.70	
						Turbo*	Base	3.08	2.73	--	--
						Hyd-Mtc	A/C	3.08	2.73	--	--
						4-Speed* (2.52:1 low)	Base	3.08	--	3.36	--
						A/C	3.08	--	3.36	--	
	427 Opt. (L68)	Three; 2-Bbl	10.25:1	400 @ 5400	460 @ 3600	4-Speed* (2.52:1 low)	Base	3.36	3.08	3.55	3.70
						A/C	3.36	3.08	3.55	3.70	
						Turbo*	Base	3.08	2.73	--	--
						Hyd-Mtc	A/C	3.08	2.73	--	--
						4-Speed* (2.20:1 low)	Base	3.55	3.36	3.70	4.11
						A/C	Not available				
427 Opt. (L71)	Three 2-Bbl	11.0:1	435 @ 5800	460 @ 4000	4-Speed* (2.20:1 low)	Base	3.55	3.36	3.70	4.11	
					A/C	Not available					

- A-Standard
- B-Economy
- C-Performance
- D-Special Purpose
- *-Optional

** -Positraction axles available optionally for 327 Cu. In. 3-Speed & 4-Speed combinations. All other engine-transmission. axle combinations are available as positraction only.

AMA Specifications—Passenger Car

MAKE OF CAR	CORVETTE	MODEL YEAR	1968	DATE ISSUED	10/15/67	REVISED (a)
MODEL	19400	327 Cu. In. V-8		427 Cu. In. V-8		
		300 HP Standard	350 HP Opt. (L79)	390 HP Opt. (L36)	400 HP Opt. (L68)	435 HP Opt. (L79)

ENGINE—GENERAL

Type, no. cyls., valve arr.	90° OHV V-8				
Bore and stroke (nominal)	4.00 x 3.25		4.25 x 3.76		
Piston displacement, cu. in.	327		427		
Bore spacing (C to C)	4.4		4.84		
No. system (front to rear)	L. Bank	1-3-5-7			
	R. Bank	2-4-6-8			
Firing order	1-8-4-3-6-5-7-2				
Compres. ratio (nominal)	10.0:1	11.0:1	10.25:1	11.0:1	
Cylinder Head Material	Cast alloy iron				
Cylinder Block Material	Cast alloy iron				
Cyl. Sleeve-Wet, dry, none	None				
Number of mtg. points	Front	Two			
	Rear	One			
Engine installation angle	3°				
Taxable horsepower	51.2		57.8		
Publishing max. bhp* @ eng. RPM	300 @ 5000	350 @ 5800	390 @ 5400	400 @ 5400	435 @ 5
Publishing max. torque* (lb. ft. @ RPM)	360 @ 3400	360 @ 3600	460 @ 3600	460 @ 3600	460 @ 4
Recommended fuel	regular - premium				

ENGINE—PISTONS

Material	Cst. al. alloy	(a)	Cast aluminum alloy	(a)
Description and finish	Flat notched head	Domed head, valve cutout		
Weight (piston only) oz.	21.60	20.64	28.00	24.67
Clearance (limits)	Top land	.0365 - .0455		.0305 - .0375
	Skirt	Top	.0005 - .0011(b)	.0024 - .0030(c)
		Bottom	.0012 - .0018(d)	
Ring groove depth	No. 1 ring	.2217 - .2283		.2348 - .2413
	No. 2 ring	.2217 - .2283		.2348 - .2413
	No. 3 ring	.2038 - .2103		.2183 - .2248
	No. 4 ring	None		

* Max. bhp (brake horsepower) and max. torque corrected to 60° F and 29.92 in. Hg atmospheric pressure.

- (a) Aluminum impact extruded
- (b) Measured 2.24 from top of piston
- (c) Measured 2.20 from top of piston
- (d) Measured 1.91 from top of piston
- (e) Measured 2.07 from top of piston

AMA Specifications—Passenger Car

MAKE OF CAR	CORVETTE		MODEL YEAR	1968	DATE ISSUED	10/15/67	REVISED (*)
	327 Cu. In. V-8				427 Cu. In. V-8		
MODEL	19400	300 HP Standard	350 HP Opt. (L79)	390 HP Opt. (L36)	400 HP Opt. (L68)	435 HP Opt. (L79)	

ENGINE - RINGS

Function (top to bottom)	No. 1, oil or comp.	Compression				
	No. 2, oil or comp.	Compression				
	No. 3, oil or comp.	Oil				
	No. 4, oil or comp.	None				
Compression	Description - Upper material, coating, etc.	Cast alloy iron; bbl. face; chrome plate on L30, Moly inlay on remainder				
	Lower	Cast alloy iron; chrome plate on L79 & L71, wear resistant ctng. on remainder				
	Width	(a)	(b)	.0770-.0775 / remainder		
	Gap	(c)			.010-.020	
Oil	Description - material, coating, etc.	Multi-piece (2 rails and one spacer expander) Rails-steel, chrome plated OD Expander-stainless steel				
	Width	.1870-.1890 (assembled)				
	Gap	.015-.055		.010-.030		
Expanders		In oil ring assembly				

ENGINE - PISTON PINS

Material	Chromium steel				
Length	2.990-3.010		2.930-2.950		
Diameter	.9270-.9273		.9895-.9898		
Type	Locked in rod, in piston, floating, etc.		Locked in rod		
	Bush- ing	In rod or piston	None		
		Material	--		
Clearance	In piston	.00015-.00025	.00045-.00055	.00025-.00035	.00030-.00040
	In rod	None			
Direction & amount offset in piston		(d)	On center	(d)	On center

ENGINE - CONNECTING RODS

Material	Drop forged steel		High alloy steel
Weight (oz.)			27.84 / 27.84
Length (center to center)	5.699-5.701		6.130-6.140
Bearing	Material & Type		Premium aluminum
	Overall length	.797	.857
	Clearance (limits)	.0007-.0027	.0009-.0029 / .0014-.0020
	End play	.009-.013	.016-.020

- (a) Upper .0775-.0780; lower .0770-.0775
- (b) Upper .0770-.0775; lower .0775-.0780
- (c) Upper .010-.020; lower .013-.025
- (d) Major thrust side .055-.065

AMA Specifications—Passenger Car

MAKE OF CAR CORVETTE MODEL YEAR 1968 DATE ISSUED 10/15/67 REVISED ^(a)

	327 Cu. In. V-8	427 Cu. In. V-8	
MODEL <u>19400</u>	300 HP Standard	350 HP Opt. (L79)	425 HP Opt. (L7)
	390 HP Opt. (L36)	400 HP Opt. (L68)	

ENGINE - CRANKSHAFT

Material	Cast nodular iron	Forged steel
----------	-------------------	--------------

Vibration damper type Rubber mounted inertia

End thrust taken by bearing (No.) Five

Crankshaft end play .002 - .006 .006 - .010

Main bearing	Material & type	Premium aluminum except No. 5 is sintered copper nickel backed babbitt			
	Clearance	(a)	(b)	(c)	
	Journal dia. and bearing overall length	No. 1	2.4502 x .752	2.7507 x .992	2.7505 x .992
		No. 2	2.4505 x .752	2.7507 x .992	2.7505 x .992
		No. 3	2.4505 x .752	2.7505 x .992	2.7505 x .992
		No. 4	2.4505 x .752	2.7505 x .992	2.7505 x .992
		No. 5	2.4507 x 1.177	2.7506 x 1.2525	2.7506 x 1.2525
	No. 6	None			
No. 7	None				
Dir. & amt. cyl. offset	None				
Crankpin journal diameter		2.099 - 2.100	2.199 - 2.200		

ENGINE - CAMSHAFT

Location In block above crankshaft

Material Cast alloy iron

Bearings Steel backed babbitt

Number 5

Gear or chain Chain

Crankshaft gear or sprocket material Steel sprocket

Camshaft gear or sprocket material Cast alloy iron Cast aluminum

No. of links 46 50

Width .740 .740

Pitch .500 .500

ENGINE - VALVE SYSTEM

Hydraulic lifters (Std., opt., NA) Standard N.A.

Valve rotator, type (intake, exhaust) None

Rocker ratio 1.50:1 1.70:1

Operating tappet clearance (indicate hot or cold) Zero .024

Intake Zero

Exhaust Zero .028

(Continued)

- (a) No. 1, .0008 - .0020; No. 2, 3, & 4, .0008 - .0024; No. 5, .0015 - .0031
- (b) No. 1 & 2, .0010 - .0020; No. 3 & 4, .0013 - .0025; No. 5, .0015 - .0031
- (c) No. 1, 2, 3 & 4, .0013 - .0025; No. 5, .0015 - .0031

AMA Specifications—Passenger Car

MAKE OF CAR CORVETTE MODEL YEAR 1968 DATE ISSUED 10/15/67 REVISED ^(a)

MODEL	19400	327 Cu. In. V-8		427 Cu. In. V-8		
		300HP Standard	350HP Opt. (L79)	390HP Opt. (L36)	400HP Opt. (L68)	435HP Opt. (L71)

ENGINE—VALVE SYSTEM (cont.)

Timing (based on top of ramp points)	Intake	Opens (°BTC)	28°	40°	40°	44°	
		Closes (°ABC)	72°	86°	80°	97°	
		Duration - deg.	280°	306°	300°	316°	
	Exhaust	Opens (°BBC)	78°	88°	88°	86°	
		Closes (°ATC)	30°	38°	32°	36°	
		Duration - deg.	288°	306°	300°	302°	
	Valve opening overlap		58°	78°	72°	80°	
	Intake	Material Alloy steel; aluminized face; also chrome flash stem on L71 & L79					
		Overall length		4.870 - 4.889		5.215 - 5.235	
		Actual overall head dia.		1.935-1.945	2.017-2.023	2.060 - 2.070	5.204-5.224
Angle of seat & face		46° (seat) 45° (face)					
Seat insert material		None					
Stem diameter		.3410-.3417		.3715-.3722			
Stem to guide clearance		.0010-.0027					
Lift (@ zero lash)		.3900	.4472	.4614	.5197		
Outer spring press. & length		Valve closed (lb.@ in.)	76-84 @ 1.70		94-106 @ 1.88		
		Valve open (lb.@ in.)	194-206 @ 1.25		303-327 @ 1.38		
Inner spring press. & length		Valve closed (lb.@ in.)	Spring damper				
		Valve open (lb.@ in.)	Spring damper				
Exhaust		Material High alloy steel; aluminized face; also chrome flash stem on L71					
		Overall length		4.913-4.933	4.891-4.910	5.345-5.365 /& L79	
		Actual overall head dia.		1.495-1.505	1.595-1.605	1.715-1.725	
	Angle of seat & face		46° (seat) 45° (face)				
	Seat insert material		None				
	Stem diameter		.3410-.3417		.3713-.3720		
	Stem to guide clearance		.0010-.0027		.0015-.0032		
	Lift (@ zero lash)		.4100	.4472	.4800	.5197	
	Outer spring press. & length	Valve closed (lb.@ in.)	76-84 @ 1.70		94-106 @ 1.88		
		Valve open (lb.@ in.)	194-206 @ 1.25		303-327 @ 1.38		
Inner spring press. & length	Valve closed (lb.@ in.)	Spring damper					
	Valve open (lb.@ in.)	Spring damper					

ENGINE—LUBRICATION SYSTEM

Type of lubrica- tion (splash, pressure, nozzle)	Main bearings	Pressure
	Connecting rods	Pressure
	Piston pins	Splash
	Camshaft bearings	Pressure
	Tappets	Pressure
	Timing gear or chain	Centrifugally oiled from front camshaft bearing
	Cylinder walls	Pressure; jet cross sprayed

(Continued)

AMA Specifications—Passenger Car

MAKE OF CAR	CORVETTE	MODEL YEAR	1968	DATE ISSUED	10/15/67	REVISED (a)
MODEL	19400	300 HP Standard	327 Cu. In. V-8 350 HP Opt. (L79)	390 HP Opt. (L36)	427 Cu. In. V-8 400 HP Opt. (L68)	435 Opt.

ENGINE - LUBRICATION SYSTEM (cont.)

Oil pump type		Gear
Normal oil pressure (lb. engine rpm)(A)	30-45 PSI @ 1500	50-75 PSI @ 2000
Oil press. sending unit (elect. or mech.)		Electric
Type oil intake (floating, stationary)		Stationary
Oil filter system (full flow, part., other)		Full flow
Filter replacement (element, complete)		Element
Capacity of c/case, less filter-refill (qt.)	4	5
Oil grade recommended (SAE viscosity and temperature range)	32° F and above - SAE 20W, SAE 10W-30 0° F to 32°F* - SAE 10W or SAE 10W-30 Below 0° F - SAE 5W or SAE 5W-20 *(SAE 5W-30 may be used at temperatures below f.	
Engine Service Reqmt. (MM, MS, etc.)		MS or DG

ENGINE - EXHAUST SYSTEM

Type (single, single with cross-over, dual, other)		Dual
Muffler No. & type (reverse flow, straight thru, separate resonator)		Two, reverse flow
Exhaust pipe dia. (O.D., wall thick.)	Branch	2.50 x .072-.092
	Main	2.50 x .084-.104 (laminated)
Tail pipe dia. (O.D. & wall thickness)		2.62 x .062-.072

ENGINE - CRANKCASE VENTILATION SYSTEM

Type (ventilates to atmos., induction system, other)	Standard	Induction system.
	Optional	
Control Unit	Make and model	AC Spark Plug 6424251 (327 cu.in); 6424250 (396 & 427 c
	Location	Left front of rocker cover
	Energy source (manifold vacuum, carburetor air stream, other)	Manifold vacuum
	Control method (variable orifice, fixed orifice, other)	Variable orifice
Complete system	Discharges (to intake manifold, carb. air intake, air cleaner intake, other)	Intake manifold
	Air inlet (breather cap, carburetor air cleaner, other)	Carburetor air cleaner
	Flame arrestor (screen, check valve, other)	Screen

A-Bench test - no flow conditions

AMA Specifications—Passenger Car

MAKE OF CAR		CORVETTE		MODEL YEAR		1968		DATE ISSUED		10/15/67		REVISED (*)		
MODEL		19400		327 Cu. In. V-8 300 HP Standard		350 HP Opt. (L79)		390 HP Opt. (L36)		427 Cu. In. V-8 400 HP Opt. (L68)		435 HP Opt. (L71)		
ENGINE - EXHAUST EMISSION CONTROL				Man.	Auto.	Manual	Man.	Auto.	Man.	Auto.	Manual			
Type (Air injection, engine modifications, other)				MANUAL TRANSMISSION - Air injection reactor equipment AUTOMATIC TRANSMISSION - Controlled combustion system										
Air Injection Pump *	Type	Semi-articulated vane type												
	Displacement	19.3												
	Drive ratio	1.15:1												
	Drive type	Crankshaft pulley												
	Relief valve (type)	Diverter valve						Pressure (plate type)						
Air Injection System *	Filter (describe)	Centrifugal air cleaner												
	Air distribution (head, manifold, etc.)	Manifold												
	Point of entry	Exhaust ports												
	Injection tube I.D.	.2565												
	Check valve type	Pressure (plate type)												
Carburetor	Backfire protection (type)	Diverter valve												
	Make	Rochester												
	Model	(a)	(b)	7028209	(c)	(d)	(e)	(f)	(c)					
	Barrel size													
	Idle speed	Drive	-	600	-	-	600	-	600	-	600	-		
	Neutral	700	-	750	700	-	750	-	750	-	750			
Idle A/F mixture	Not specified													
Aux. Adv. Systems (type)	None													
Distributor	Make	Delco-Remy												
	Model	1111194			1111438			1111293			1111296			
	Cent'gal adv. in crank degrees @ eng. rpm	Start (rpm)	900			950			900			900		
		Intermed. points deg. @ rpm	15@1500			20@1800			17@2000			None		
		Max. deg. @ rpm	30@5100			30@4700			32@5000			30@3800		
	Vacuum adv. in crank degrees @ eng. rpm	Start (in Hg)	6.00			6.00			7.00			8.00		
		Intermed. points deg. @ in. Hg	None											
		Max. deg. @ in.	15 @ 12			15 @ 15.5			12 @ 12			15 @ 15.5		
Vacuum Source	Carburetor													
Timing - Crank degrees @ rpm	4BTC at idle													
Cooling System (describe changes)	None													
Exhaust System (describe changes)	None													

* - Used with manual transmissions only.

(a) 7028207 (c) 7028209 (e) 3925517 Primary; 3902353 Secondary
 (b) 7028208 (d) 7028216 (f) 3925516 Primary; 3902353 Secondary

AMA Specifications—Passenger Car

MAKE OF CAR CORVETTE MODEL YEAR 1968 DATE ISSUED 10/15/67 REVISED ^(a)

MODEL	19400	327 Cu. In. V-8		427 Cu. In. V-8		
		300 HP Standard	350 HP Opt. (79)	390 HP Opt. (L36)	400 HP Opt. (L68)	435 H Opt. (L

ENGINE - FUEL SYSTEM

(See supplemental page for Details of Fuel Injection, Supercharger, etc. if used)

Induction type: Carburetor, fuel injection, supercharger.		Carburetor				
Fuel Tank	Refill capacity (U.S. gals.)	20 (approximately)				
	Filler location	Center at rear deck				
Fuel Pump	Type (elec. or mech.)	Mechanical				
	Locations	Lower right front of engine				
	Pressure range	5.00 - 6.50 PSI				
Vacuum booster (std., optional, none)		None				
Fuel Filter	Type	Fine mesh plastic strainer in gas tank and paper filter in carburetor inlet				
	Locations	Automatic				
Carburetor	Choke type	Exhaust				
	Intake manifold heat control (exhaust or water)	Automatic				
	Air cleaner type	Standard	Oil-wetted paper element			Polyurethane
		Optional				
	Idle speed (spec. neutral or drive)	Manual	700	750	700	750
Automatic		600	NA	600	600 NA	
Idle A/F mix.						

CARBURETOR SUPPLEMENTARY INFORMATION

Model Usage	Engine Displ.	Transmission	Carburetors		No. Used and Type	Bore Size
			Make	Model		
19400	300 hp	3- spd & 4- spd	Rochester	7028207	One; 4- Bbl down-draft	1.38 (prim) 2.25 (sec)
		Turb Hyd-Mtc.	Rochester	7028208		
		4-Speed	Rochester	7028219		
		350 hp	4-Speed	Rochester		
	390 hp	Turb Hyd-Mtc.	Rochester	7028216		
		4-Speed	Holley	3925517 (primary) 3902353 (secondary)	Three; 2- Bbl (1-prim) (2-sec)	1.50 (prim) 1.75 (seco)
	400 hp	Turbo Hydra-Matic	Holley	3925516 (primary) 3902353 (secondary)		
		427	4-Speed	Holley		
435 hp	4-Speed	Holley	3925517 (primary) 3902353 (secondary)			

AMA Specifications—Passenger Car

MAKE OF CAR CORVETTE MODEL YEAR 1968 DATE ISSUED 10/15/67 REVISED ^(*)

MODEL	<u>19400</u>	327 Cu. In. V-8		427 Cu. In. V-8		
		300 HP. Standard	350 HP. Opt. (L79)	390 HP. Opt. (L36)	400 HP. Opt. (L68)	435 HP. Opt. (L71)

ENGINE—COOLING SYSTEM

Type system (pressure, pressure vented, atmospheric, other)	Pressure with surge tank		Pressure			
Radiator cap relief valve pressure			15 ± 1 PSI			
Circulation thermostat	Type (choke, bypass)	Choke				
	Starts to open at (°F)	192°-198°				
Water pump	Type (centrifugal, other)	Centrifugal				
	GPM @ 1000 pump rpm	57 @ 4400	82 @ 5200			
	Number of pumps	One				
	Drive (V-belt, other)	V-Belt				
	Bearing type	Double row ball				
By-pass recirculation type (inter., ext.)	Internal	External				
Radiator core type (cellular, tube and fin, other)	Cross flow					
Cooling system capacity	With heater (qt.)	15	22			
	Without heater (qt.)	14	21			
	Opt. equipment-specify (qt.)					
Water jackets full length of cyl. (yes, no)	Yes					
Water all around cylinder (yes, no)	Yes					
Radiator hose	Lower	Number and type (molded, straight)	One, molded			
		Inside diameter	1.75	1.88		
	Upper	Number and type (molded, straight)	One, molded			
		Inside diameter	1.50			
	By-pass	Number and type (molded, straight)	None	One, molded		
		Inside diameter	None	.725-.765		
Fan	Number of blades & spacing	5-staggered				
	Diameter	17.50				
	Ratio-fan to crankshaft rev.	.949:1				
	Fan cutout type	Thermo-modulated-viscous coupling				
	Bearing type	Double row ball				
*Drive belts (indicate belt used by letter)	Fan	A	EF	JF		
	Generator or alternator	A	E	J		
	Water Pump	A	EF	JF		
	Power Steering	B	G	G	G	NA
	Air Conditioning	C	H	K	K	NA
	Air Injection Pump	D	I	I	I	I

* Drive Belt Dimensions	A	B	C	D	E	F	G	H	I	J	K
Angle of V	←				38°—42°	→					
Nominal length (SAE)	53.25	36.25	57.50	34.00	54.00	34.40	45.00	56.75	33.50	56.00	45.71
Width	←				.380	→					

AMA Specifications—Passenger Car

MAKE OF CAR CORVETTE MODEL YEAR 1968 DATE ISSUED 10/15/67 REVISED ^(a)

MODEL	19400	327 Cu. In. V-8		427 Cu. In. V-8		
		300HP Standard	350HP Opt. (L79)	390HP Opt. (L36)	400HP Opt. (L68)	435HP Opt. (L79)

ELECTRICAL – SUPPLY SYSTEM

Battery	Make and Model		Delco-Remy 1980087			
	Voltage Rtg. & Total Plates		12 volt-78 plate			
	SAE Designation & Amp. Hr. Rtg.		62 amp/hr @ 20 hr. rate			
	Location		Behind driver seat in stowage compartment			
	Terminal grounded		Negative			
Generator or Alternator	Make		Delco-Remy			
	Model		1100696			
	Type and rating		Diode rectified 9-37 amps.			
	Output at engine idle (neutral)		13 amps	22 amps	16 amps	24 amp
Ratio-Gen. to Cr/s rev.		2.46:1				
Regulator	Make		Delco-Remy			
	Model		1119515			
	Type		Vibrator			
	Cutout relay	Closing voltage generator rpm	None			
		Reverse current to open	None			
	Regu- lated	Voltage	13.8-14.8 @ 85° F			
		Current	---			
	Voltage test conditions	Temperature	Operating			
Load		3-8 amperes				
Other		None				

ELECTRICAL – STARTING SYSTEM

Starting Motor	Make		Delco-Remy			
	Model		1108361			1107365
	Rotation (drive end view)		Clockwise			
Motor control	Switch (solenoid, manual)		Solenoid			
	Starting procedure		3-Spd & 4-Spd- Place gearshift lever in neutral and depre AUTOMATIC- Place control lever in "N" or "P" position /c INITIAL START- Press accelerator to floor and release. ignition to START, release as soon as engine starts.			
Motor Drive	Engagement type		Position shift solenoid			
	Pinion meshes (front, rear)		Rear			
	Number of teeth	Pinion	9			
		Flywheel	Manual	153		
	Flywheel tooth face width	Manual	Auto.	153	NA	168
Auto.			.4010-.4130	NA	.4100-.4220	NA

AMA Specifications—Passenger Car

MAKE OF CAR CORVETTE MODEL YEAR 1968 DATE ISSUED 10/15/67 REVISED ^(*)

MODEL	19400	327 Cu. In. V-8		427 Cu. In. V-8		
		300 HP Standard	350 HP Opt. (L79)	390 HP Opt. (L36)	400 HP Opt. (L68)	435 HP Opt. (L7)

ELECTRICAL - IGNITION SYSTEM

Type	Conventional - Std., Opt., N.A.	Standard			NA	
	Transistorized - Std., Opt., N.A.	NA	Optional		Standard	
	Other (specify)	None				
Coil	Make					
	Model	1115270	1115287			
	Amps	Engine stopped	4.0			
	Engine idling	1.8				
Distributor	Make	Delco-Remy				
	Model	1111194	1111438	1111293	1111296	
	Cent'gal adv. in c/shaft degrees @ engine rpm (nominal)	Start (rpm)	900	950	900	900
		Intermediate points deg. @ rpm	15@1500	20@1800	17@2000	None
		Max. deg. @ rpm	30@5100	30@4700	32@5000	30@5800
	Vacuum adv. in c/shaft degrees @ in. Hg. (nominal)	Start (in. Hg.)	6.00	6.00	7.00	8.00
		Intermediate points, deg. @ in. Hg.				
		Max. deg. in. Hg.	15 @ 12	15 @ 15.5	12 @ 12	15 @ 15.
	Breaker gap (in.)	.019			Magnetic	
	Cam angle (deg.)	28-32			Pulse	
Breaker arm tension (oz.)	19-23	28-32		amplified		
Timing	Crankshaft deg. @ rpm	4BTC at idle				
	Mark location	Torsional damper				
Spark Plug	Make	AC Spark Plug				
	Model	AC44	AC43N			
	Thread (mm)	14				
	Tightening torque (lb. ft.)	25				
	Gap	.033-.038				
Cable	Conductor type	Linen core impregnated with electrical conducting				
	Insulation type	Rubber with neoprene jacket				
	Spark plug protector	Hypalon jacket				

ELECTRICAL - SUPPRESSION

Locations & type	Non-metallic, high tension ignition
------------------	-------------------------------------

AMA Specifications—Passenger Car

MAKE OF CAR CORVETTE MODEL YEAR 1968 DATE ISSUED 10/15/67 REVISED ^(*)

MODEL	19400	327 Cu. In. V-8		427 Cu. In. V-8		
		300 HP Standard	350 HP Opt. (L79)	390 HP Opt. (L36)	400 HP Opt. (L68)	435 HP Opt. (L71)

ELECTRICAL - INSTRUMENTS AND EQUIPMENT

Speed-ometer	Type	Dial
	Trip odometer (yes, no)	Yes
Chdrge indicator - type		Ammeter
Temperature indicator - type		Electric gauge
Oil pressure indicator - type		Bourdon tube gauge
Fuel indicator - type		Electric gauge
Other		Mechanical tachometer
Wind-shield wiper	Type - Standard	Electric two-speed
	Type - Optional	None
Wind-shield washer	Type - Standard	Push-button
	Type - Optional	None
Horn	Type	Vibrator
	Number used	Two
	Amp draw (each)	(low note) 4.5-6.5 @ 12.5V. (Hi note) 4.2-6 @ 12.5V. ;

DRIVE UNITS - CLUTCH (Manual Transmission)

Make & type	3 & 4-Spd	4-Speed
	Chevrolet, single dry disc, semi-centrifugal	
Type pressure plate springs	Circular plate diaphragm, bent finger design	
Total spring load (lb.)	2100-2300	2300-2600
No. of clutch driven discs	One	
	Premium grade woven type asbestos	
Clutch facing	Material	Premium grade woven type asbestos
	Outside & inside dia.	10.34 & 6.50
	Total eff. area (sq.in.)	101.54
	Thickness	.135 each
Engagement cushioning method	Flat spring steel between cushions	
Release bearing	Type & method of lubrication	Single row ball, packed and sealed
Torsional damping	Methods: springs, friction material	Coil springs

AMA Specifications—Passenger Car

MAKE OF CAR	CORVETTE		MODEL YEAR	1968	DATE ISSUED	10/15/67 REVISED (*)		
				327 Cu. In. V-8		427 Cu. In. V-8		
MODEL	300 HP Standard	350 HP Opt. (L79)	390 HP Opt. (L36)	400 HP Opt. (L68)	435 HP Opt. (L71)			

DRIVE UNITS – TRANSMISSIONS

Manual 3-speed (std. or opt.)	Standard available with 327 Cu. In. 300 HP only
Manual 4-speed (std. or opt.)	Optional
Manual with overdrive (std. or opt.)	Not available
Automatic (std. or opt.)	Turbo Hydra-Matic optional with 300 HP (std) 390 HP (L3

DRIVE UNITS – MANUAL TRANS.

& 400 HP (L68) only

		3-Speed(a)	4-Speed(b)	4-Speed(c)
Number of forward speeds		3	4	4
Transmission ratios	In first	2.54:1	2.52:1	2.20:1
	In second	1.50:1	1.88:1	1.64:1
	In third	1.00:1	1.47:1	1.27:1
	In fourth	--	1.00:1	1.00:1
	In reverse	2.63:1	2.59:1	2.26:1
Synchronous meshing, specify gears		All forward gears		
Shift lever location		Floor mounted		
Lubricant		3		
Capacity (pt.)		Meeting Military specs. MIL-L-2105B		
Type recommended				
SAE viscosity number	Summer	SAE 80		
	Winter	SAE 80		
	Extreme cold	SAE 80		

DRIVE UNITS – MANUAL TRANS. W/OVERDRIVE

(For transmission data see manual transmission section)

Type (planetary or other)			
Manual lockout (yes, no)		NOT	
Downshift accelerator control (yes, no)			
Minimum cut-in speed		AVAILABLE	
Gear ratio			
Lubricant	Capacity (pt.) (Overdrive only)		
	Separate filler (yes, no)		
	Type recommended		
	SAE viscosity number	Summer	
		Winter	
	Extreme cold		

- (a) Available with 327 Cu. In. 300 HP (Std.) only
 (b) Available with all engine combinations except 427 Cu. In. 435 HP (L71)
 (c) Available with all engine combinations except 327 Cu. In. 300 HP (Std.)

AMA Specifications—Passenger Car

MAKE OF CAR CORVETTE MODEL YEAR 1968 DATE ISSUED 10/15/67 REVISED ^(*)

MODEL	19400	327 Cu.In.	427 Cu.In.
DRIVE UNITS—AUTOMATIC TRANSMISSION	Available with 327 Cu. In. 300 HP (Std.) & 427 Cu. In. 390 HP (L36) & 400 HP (L68) only		
Trade name	Turbo Hydra-Matic		
Type describe	Torque converter with planetary gears		
Selector location	Lever (floor mounted)		
List gear ratios Selector Pattern and indicate which are used in each selector position	P - Park R - 2.08 N - Neutral D - 2.48-1.48-1.00 L ₂ - 2.48-1.48 L ₁ - 2.48		
Max. upshift speed—drive range	51(1-2); 95(2-3)	51(1-2); 90(2-3)	
Max. kickdown speed—drive range	44(2-1); 88(3-2)	40(2-1); 84(3-2)	
Torque converter	Number of elements	3	
	Max. ratio at stall	2.30	2.04
	Type of cooling (air, liquid)	Water	
Lubricant	Nominal diameter	12.20	
	Capacity—refill (pt.)	8	
	Type recommended	A suffix A	
Special transmission features			

DRIVE UNITS—PROPELLER SHAFT

Number used	One		
Type (straight tube, tube-in-tube, internal-external damper, etc.)	Straight tube		
Outer diam. x length* x wall thickness	Manual 3-speed trans.	2.00 x 29.90 x .095	
	Manual 4-speed trans.	2.00 x 29.90 x .095	
	Overdrive transmission	Not available	
	Automatic transmission	2.00 x 29.50 x .095	

* Center to center of universal joints, or to centerline of rear attachment.

(Continued)

AMA Specifications—Passenger Car

MAKE OF CAR CORVETTE MODEL YEAR 1968 DATE ISSUED 10/15/67 REVISED (*)

MODEL
DRIVE UNITS – PROPELLER SHAFT (cont.)

Inter-mediate bearing	Type (plain, anti-friction)	None
	Lubrication (fitting, prepack)	---
Slip Yoke	Type	Yoke
	Number of teeth	27
	Spline O.D.	1.1750
Universal joints	Make and Mfg. No.	Chevrolet, 3868728
	Number used	Two
	Type (ball and trunnion, cross)	Cross
	Rear attach. (u-bolt, clamp, etc.)	V-Belt
	Bearing	Type (plain, anti-friction)
Lubric. (fitting, prepack)		Prepack
Drive taken through (torque tube or arms, springs)		Torque control arms
Torque taken through (torque tube or arms, springs)		Torque control arms

DRIVE UNITS – AXLE

Type (front, rear)	Rear		
Description	Semi-floating, overhung pinion gear		
Limited Slip differential, type	Dual disc clutches		
Drive Pinion Offset	1.5		
No. of differential pinions	2		
Pinion adjustment (shim, other)	None		
Pinion bearing adj. (shim, other)	Shim		
Wheel bearing type	Taper roller		
Lubricant	Capacity (pt.)	3.7	
	Type recommended	Meeting Military Specs MIL-L-2105-B	
	SAE viscosity number	Summer	SAE 80
		Winter	SAE 80
Extreme cold		SAE 80	

AXLE RATIO TOOTH COMBINATIONS

(See page 3 for axle ratio usage)

Axle ratio	2.73	3.08	3.36	3.55	3.70	4.11
No. of teeth	Pinion	15	12	11	9	10
	Ring gear	41	37	37	32	37
Ring Gear O.D.	8.375					

AMA Specifications—Passenger Car

The information contained herein is prepared, distributed by, and is solely the responsibility of the automobile manufacturing company to whose products it relates. Questions concerning these specifications should be directed to the manufacturer whose address is shown below. This uniform specification form was developed by the automobile manufacturing companies under the auspices of the Automobile Manufacturers Association.

MANUFACTURER Chevrolet Motor Division General Motors Corporation	CAR NAME CORVETTE
MAILING ADDRESS Chevrolet Owner-Relation Dept. 1400 Broadway, Detroit, Mich. 48202	MODEL YEAR 1968 ISSUED: 10-15-67 REVISED (e)

NOTES:

1. The Specifications herein are those in effect at date of compilation and are subject to change without notice by the manufacturer.
2. UNLESS OTHERWISE INDICATED:
 - a. Specifications apply to standard models without optional equipment. Significant deviations are noted.
 - b. Nominal design dimensions are used throughout these specifications.

TABLE OF CONTENTS

Car & Body Dimensions	1, 2	Drive Units	14	Suspensions	21
Engine - Mechanical	4	Brakes	18, 19	Weights	24
Electrical	12	Steering	20	Index	27

BODY - TYPES AND STYLE NAMES -

Body type, number of passenger & style names; use manufacturer's code for series & body style.

	427 Cu. In.
	V-8 430 HP
	Opt (L88)
2-Door Sport Coupe, 2-Pass.	19437
2-Door Convertible, 2-Pass.	19467

FILE COPY - DO NOT REMOVE
OWNER RELATIONS DEPARTMENT

AMA Specifications—Passenger Car

MAKE OF CAR CORVETTE MODEL YEAR 1968 DATE ISSUED 10-15-67 REVISED (*)

CAR AND BODY DIMENSIONS

See Pages 25, 26 for SAE Dimension Definitions

(All dimensions in inches unless otherwise indicated)

All dimensions to ground are for comparative purposes only and are shown with vehicle load of two passengers in front and three in rear, except where otherwise noted.

MODEL	19400	SAE Ref. No.	SPORT COUPE		CONVERTIBLE	
					SOFT TOP	HARDTOP
WIDTH						
	Track - Front	W101			58.3	
	Track - Rear	W102			59.0	
	Maximum overall car width	W103			69.2	
	Width at No. 2 pillar	W117				
LENGTH						
	Body "O" to front of dash	L 30				
	Wheelbase	L101			98.0	
	Overall car length	L103			182.1	
	Overhang - front	L104			40.2	
	Overhang - rear	L105			43.9	
	Body upper structure length	L123	54.7			
	Body "O" line to ϵ of rear wheel	L127			72.0	
	Body "O" line to w/s cowl point	L130			11.6	
HEIGHT						
	Overall height	H101	47.8			
	Cowl height	H114			26.6	
	Deck height	H138				
Rocker panel - front	To ground	H112			7.6	
	From front wheel ϵ					
Rocker panel - rear	To ground	H111			7.6	
	From rear wheel ϵ					
	Windshield slope angle	H122			57	
GROUND CLEARANCE						
	Bumper to ground - front	H102			9.2	
	Bumper to ground - rear	H104			12.3	
	Angle of approach	H106			22	
	Angle of departure	H107			21	
	Ramp breakover angle	H147			22	
	Min. running clearance (Specify)	H156			4.9 (Exhaust to ground)	

AMA Specifications—Passenger Car

MAKE OF CAR CORVETTE MODEL YEAR 1968 DATE ISSUED 10-15-67 REVISED (a)

CAR AND BODY DIMENSIONS

See Pages 25, 26 for SAE Dimension Definitions
(All dimensions in inches unless otherwise indicated)

MODEL	19400	SAE Ref. No.	SPORT COUPE	CONVERTIBLE	
				SOFT TOP	HARDTOP
FRONT COMPARTMENT					
Effective head room	H61	36.2	37.1	36.0	
Max. eff. leg room - accelerator	L34		43.0		
H Point to Heel point	H30		6.5		
H Point travel	L17		4.5		
Shoulder room	W 3		46.9		
Hip room	W 5		48.8		
Upper body opening to ground	H50		43.6		
REAR COMPARTMENT					
H Point couple distance	L50		--		
Effective head room	H63		--		
Min. effective leg room	L51		--		
H Point to Heel point	H31		--		
Min. knee room	L48		--		
Rear Compartment room	L 3		--		
Shoulder room	W 4		--		
Hip room	W 6		--		
Upper body opening to ground	H51		--		
LUGGAGE COMPARTMENT					
Usable luggage capacity	V 1				
Liftover height	H195				
Position of spare tire storage					
Method of holding lid open					
STATION WAGON - THIRD SEAT					
Shoulder Room	W85				
Hip room	W86				
Effective leg room	L86		NOT AVAILABLE		
Effective head room	H86				
Seat facing direction					
STATION WAGON - CARGO SPACE					
Cargo length at floor - front seat	L202				
Cargo length at belt - front seat	L204				
Cargo width - wheelbase	W201				
Opening width at belt	W204		NOT AVAILABLE		
Maximum cargo height	H201				
Rear opening height	H202				
Cargo volume index (cu. ft.)	V2				
$\frac{W8 \times L204 \times H201}{1728}$					

AMA Specifications—Passenger Car

MAKE OF CAR CORVETTE MODEL YEAR 1968 DATE ISSUED 10-15-67 REVISED (*)

POWER TEAMS

(Indicate whether standard or optional)

MODEL AVAILABILITY	ENGINE					TRANSMISSION	AXLE RATIO * (Std. first) (Indicate A C ratio)			
	Displ. cu. in.	Carburetor	Compr. Ratio	BHP RPM	Torque RPM		A	B	C	D
19400	427 430 HP	4-bbl	12.5:1	430 @ 4600	485 @ 4000	4-Speed * (2.20:1 low)	3.36	3.08	3.55	3.70 4.11 4.56

- A-Standard
- B-Economy-Optional
- C-Performance-Optional
- D-Special Purpose-Optional

*-All engine-axle combinations are available as positraction only.

AMA Specifications—Passenger Car

MAKE OF CAR CORVETTE MODEL YEAR 1968 DATE ISSUED 10-15-67 REVISED ^(a)
 MODEL 19400 427 Cu. In. V-8
 430 HP Opt. (L88)

ENGINE - GENERAL

Type, no. cyls., valve arr.	90° OHV V-8	
Bore and stroke (nominal)	4.25 x 3.76	
Piston displacement, cu. in.	427	
Bore spacing (C to C)	4.84	
No. system (front to rear)	L. Bank	1-3-5-7
	R. Bank	2-4-6-8
Firing order	1-8-4-3-6-5-7-2	
Compression ratio (nominal)	12.5:1	
Head Material	Aluminum alloy	
Block Material	Cast alloy iron	
Lubrication	None	
Number of mtg. points	Front	Two
	Rear	One
Engine installation angle	3°	
Taxable horsepower	$\frac{\text{Dia}^2 \times \text{No. Cyl.}}{2.5}$	57.8
Publishing max. bhp* @ eng. RPM	430 @ 4600	
Publishing max. torque* (lb. ft. @ RPM)	485 @ 4000	
Recommended fuel Regular - premium	Premium	

ENGINE - PISTONS

Material	Aluminum impact extruded		
Description and finish	Domed head, valve cutout		
Weight (piston only) oz.	28.99		
Clearance (inits)	Top land	.0316-.0384	
	Skirt	Top	.0058-.0066 (a)
		Bottom	--
Ring groove depth	No. 1 ring	.2373-.2437	
	No. 2 ring	.2373-.2437	
	No. 3 ring	.2158-.2173	
	No. 4 ring	None	

* Max. bhp (brake horsepower) and max. torque corrected to 60° F and 29.92 in. Hg atmospheric pressure.

(a) Measured 2.20 from top of piston

AMA Specifications—Passenger Car

MAKE OF CAR CORVETTE MODEL YEAR 1968 DATE ISSUED 10-15-67 REVISED (*)MODEL 19400427 Cu. In. V-8
430 HP Opt. (L88)

ENGINE - RINGS

Function (top to bottom)	No. 1, oil or comp.	Compression
	No. 2, oil or comp.	Compression
	No. 3, oil or comp.	Oil
	No. 4, oil or comp.	None
Compression	Description - material, coating, etc.	Cast alloy iron; barrel face; no bevel; molybdenum inlay
	Width	.0620-.0625
	Gap	.015-.025
Oil	Description - material, coating, etc.	Multi-piece (2 rails and one spacer expander) Rails-steel, chrome plated OD Expander - stainless steel
	Width	.1870-.1890
	Gap	.010-.030
Expanders		In oil ring assembly

ENGINE - PISTON PINS

Material	Chromium Steel		
Length	2.930-2.905		
Diameter	.9895-.9898		
Type	Locked in rod, in piston, floating, etc.	Locked in rod	
	Bush- ing	In rod or piston	None
		Material	
Clearance	In piston	.00030-.00040	
	In rod	None	
Direction & amount offset in piston	On center		

ENGINE - CONNECTING RODS

Material	High alloy steel	
Weight (oz.)	27.84	
Length (center to center)	6.130-6.140	
Bearing	Material & Type	Premium aluminum
	Overall length	.857
	Clearance (limits)	.0014-.0034
	End play	.016-.020

AMA Specifications—Passenger Car

MAKE OF CAR CORVETTE MODEL YEAR 1968 DATE ISSUED 10-15-67 REVISED ^(*)

427 Cu. In. V-8

MODEL 19400

430 HP Opt. (L88)

ENGINE - CRANKSHAFT

Material		Forged steel	
Vibration damper type		Rubber mounted inertia	
End thrust taken by bearing (No.)		Five	
Crankshaft end play		.006-.010	
Main bearing	Material & type	Premium aluminum except No. 5 is sintered copper nickel backed babbitt.	
	Clearance	#1, 2, 3, & 4 - (.0013-.0025); #5 - (.0015-.0031)	
	Journal dia. and bearing overall length	No. 1	2.7510 x .992
		No. 2	2.7510 x .992
		No. 3	2.7505 x .992
		No. 4	2.7505 x .992
		No. 5	2.7506 x 1.2525
		No. 6	None
No. 7		None	
Dir. & amt. cyl. offset		None	
Crankpin journal diameter		2.199- 2.200	

ENGINE - CAMSHAFT

Location		In block above crankshaft	
Material		Cast alloy iron	
Bearings	Material	Steel backed babbitt	
	Number	Five	
Type of Drive	Gear or chain		Chain
	Crankshaft gear or sprocket material		Steel sprocket
	Camshaft gear or sprocket material		Cast aluminum
	Timing chain	No. of links	50
		Width	.880
Pitch		.550	

ENGINE - VALVE SYSTEM

Tappet lifters (Std., opt., NA)		Not available
Valve rotor, type (intake, exhaust)		None
Rocker ratio		1.70:1
Operating tappet clearance (indicate hot or cold)	Intake	.024
	Exhaust	.028

(Continued)

AMA Specifications—Passenger Car

TYPE OF CAR CORVETTE MODEL YEAR 1968 DATE ISSUED 10-15-67 REVISED (6)

MODEL 19400 427 Cu. In. V-8
430 HP Opt. (L88)

ENGINE—VALVE SYSTEM (cont.) *SEE CHOO MAN FOR DIFF!* Intake — .3286" + .002
Exhaust — .3412" — .002

Timing (based on top of ramp points)	Intake	Opens (°BTC)	62°	
		Closes (°ABC)	105°	
		Duration - deg.	347°	
	Exhaust	Opens (°BBC)	110°	
		Closes (°ATC)	74°	
		Duration - deg.	364°	
Valve opening overlap			136°	
Intake	Material		Alloy steel; aluminized face and chrome flash stem	
	Overall length		5.204-5.224	
	Actual overall head dia.		2.185-2.195	
	Angle of seat & face		46° (seat) 45° (face)	
	Seat insert material		Nickel Moly Alloy	
	Stem diameter		.3715-.3722	
	Stem to guide clearance		.0010-.0027	
	Lift (± zero lash)		.5586	
	Outer spring press. & length	Valve closed (lb. @ in.)	69-81 @ 1.88	
		Valve open (lb. @ in.)	181-205 @ 1.32	
	Inner spring press. & length	Valve closed (lb. @ in.)	37-45 @ 1.78	
		Valve open (lb. @ in.)	92-110 @ 1.22	
	Exhaust	Material		High alloy steel; aluminized face
		Overall length		5.345-5.365
		Actual overall head dia.		1.835-1.845
Angle of seat & face		46° (seat) 45° (face)		
Seat insert material		Nickel Moly Alloy		
Stem diameter		.3713-.3720		
Stem to guide clearance		.0015-.0032		
Lift (± zero lash)		.5800		
Outer spring press. & length		Valve closed (lb. @ in.)	69-81 @ 1.88	
		Valve open (lb. @ in.)	181-205 @ 1.32	
Inner spring press. & length		Valve closed (lb. @ in.)	37-45 @ 1.78	
		Valve open (lb. @ in.)	92-110 @ 1.22	

ENGINE—LUBRICATION SYSTEM

Type of lubrica- tion (splash, pressure, etc)	Main bearings	Pressure
	Connecting rods	Pressure
	Piston pins	Splash
	Camshaft bearings	Pressure
	Tappets	Pressure
	Timing gear or chain	Centrifugally oiled from camshaft bearing
	Cylinder walls	Pressure, jet cross sprayed

(Continued)

AMA Specifications—Passenger Car

MAKE OF CAR CORVETTE MODEL YEAR 1968 DATE ISSUED 10-15-67 REVISED (*)MODEL 19400427 Cu. In. V-8
430 HP Opt. (L88)

ENGINE - LUBRICATION SYSTEM (cont.)

Oil pump type	Gear
Normal oil pressure (lb. engine rpm)	50-75 PSI @ 2000 (A)
Oil press. sending unit (elect. or mech.)	Electric
Type oil intake (floating, stationary)	Stationary
Oil filter system (full flow, part., other)	Full flow
Filter replacement (element, complete)	Element
Capacity of c. case, less filter-refill (qt.)	5
Oil grade recommended (SAE viscosity and temperature range)	* 32°F. and above - SAE 20W, SAE 10W-30 0°F. to 32°F. *- SAE 10W or SAE 10W-30 Below 0°F. - SAE 5W or SAE 5W-20 * (SAE 5W-30 may be used at temperature below freezing)
Engine Service Reqmt. (MM, MS, etc.)	MS or DG

ENGINE - EXHAUST SYSTEM

Type (single, single with cross-over, dual, other)	Dual
Muffler No. & type (reverse flow, straight thru, separate resonator)	Two, reverse flow
Exhaust pipe dia. (wall thick.)	Branch
	Main
Branch	2.50 x .072-.092
Main	2.50 x .084-.014 laminated
Tail pipe dia. (O.D. & wall thickness)	2.62 x .062-.072

ENGINE - CRANKCASE VENTILATION SYSTEM

Type (ventilates to atmos., induction system, other)	Standard	Induction System
	Optional	--
Control Unit	Make and model	AC Spark Plug 6424250
	Location	Left front of rocker cover
	Energy source (manifold vacuum, carburetor air stream, other)	Manifold vacuum
	Control method (variable orifice, fixed orifice, other)	Variable orifice
Complete system	Discharges (to intake manifold, carb. air intake, air cleaner intake, other)	Intake manifold
	Air inlet (breather cap, carburetor air cleaner, other)	Carburetor air cleaner
	Flame arrester (screen, check valve, other)	Screen

A - Bench test - no flow condition.

AMA Specifications—Passenger Car

MAKE OF CAR CORVETTE MODEL YEAR 1968 DATE ISSUED 10-15-67 REVISED (*)MODEL 19400427 Cu. In. V-8
430 HP - Manual Transmission

ENGINE - EXHAUST EMISSION CONTROL

Type (Air injection, engine modifications, other)		Air Injection	
Air Injection Pump	Type	Semi-articulated vane type	
	Displacement	19.3 cubic inches	
	Drive ratio	1.15:1	
	Drive type	Crankshaft pulley	
	Relief valve (type)	Pressure (plate type)	
	Filter (describe)	Centrifugal air cleaner	
Air Injection System	Air distribution (head, manifold, etc.)	Manifold	
	Point of entry	Exhaust ports	
	Injection tube I.D.	.2565	
	Check valve type	Pressure (plate type)	
	Backfire protection (type)	Diverter valve	
Carburetor	Make	Holley	
	Model	3925519	
	Barrel size	1.75 primary & secondary	
	Idle speed	Drive	1000
		Neutral	--
Idle A/F mixture	Not specified		
Distributor	Aux. Adv. Systems (type)	None	
	Make	Delco Remy	
	Model	1111295	
	Cent'fgal adv. in crank degrees @ eng. rpm	Start (rpm)	5000
		Intermed. points deg. @ rpm	18 @ 1900
		Max. deg. @ rpm	30 @ 5000
	Vacuum adv. in crank degrees @ eng. rpm	Start (in Hg)	None
		Intermed. points deg. @ in. Hg	
Max. deg. @ in.		None	
Vacuum Source	Carburetor		
Timing - Crank degrees @ rpm	12 BTDC @ Idle		
Cooling System (describe changes)	None		
Exhaust System (describe changes)	None		

AMA Specifications—Passenger Car

NAME OF CAR CORVETTE MODEL YEAR 1968 DATE ISSUED 10-15-67 REVISED (a)

MODEL 19400 427 Cu. In. V-8
430 HP Opt (L88)

ENGINE - FUEL SYSTEM (See supplemental page for Details of Fuel Injection, Supercharger, etc. if used)

Induction type: Carburetor, fuel injection, supercharger.		Carburetor	
Fuel Tank	Refill capacity (U.S. gals.)	20 (approximately)	
Fuel Tank	Filler location	Center at rear deck	
Fuel Pump	Type (elec. or mech.)	Mechanical	
Fuel Pump	Locations	Lower right front of engine	
Fuel Pump	Pressure range	5.00-6.50 PSI	
Vacuum booster (std., optional, none)		None	
Fuel Filter	Type	Fine mesh plastic strainer in gas tank and paper filter in carburetor inlet	
Fuel Filter	Locations	Automatic	
Choke type		Exhaust	
Intake manifold heat control (exhaust or water)		Exhaust	
Carburetor	Air cleaner type	Standard	Oil-wetted paper element
		Optional	None
	Idle speed (spec. neutral or drive)	Manual	1000
		Automatic	--
Idle A/F mix.		Not specified	

CARBURETOR SUPPLEMENTARY INFORMATION

Model Usage	Engine Displ.	Transmission	Carburetors		No. Used and Type	Barrel Size
			Make	Model		
19400	427	4-Speed	Holley	3925519	One; 4-bbl	1.750 Primary & Secondary

AMA Specifications—Passenger Car

MAKE OF CAR CORVETTE MODEL YEAR 1968 DATE ISSUED 10-15-67 REVISED (*)

MODEL	19400	427 Cu. In. V-8 430 HP Opt (L88)
-------	-------	-------------------------------------

ENGINE - COOLING SYSTEM

Type system (pressure, pressure vented, atmospheric, other)		Pressure	
Radiator cap relief valve pressure		15 ± 1 PSI	
Circulation thermostat	Type (choke, bypass)	Choke	
	Starts to open at (°F)	192°-198°	
Water pump	Type (centrifugal, other)	Centrifugal	
	GPM @ 1000 pump rpm	82 @ 5200	
	Number of pumps	One	
	Drive (V-belt, other)	V-Belt	
Bearing type		Double row ball	
By-pass recirculation type (inter., ext.)		External	
Radiator core type (cellular, tube and fin, other)		Cross flow	
Cooling system capacity	With heater (qt.)	22	
	Without heater (qt.)	21	
	Opt. equipment-specify (qt.)	--	
Water jackets full length of cyl. (yes, no)		Yes	
Water all around cylinder (yes, no)		Yes	
Radiator hose	Lower	Number and type (molded, straight)	One, molded
		Inside diameter	1.88
	Upper	Number and type (molded, straight)	One, molded
		Inside diameter	1.50
	By-pass	Number and type (molded, straight)	One, molded
		Inside diameter	.725-.765
Fan	Number of blades & spacing		5 Staggered
	Diameter		17.50
	Ratio-fan to crankshaft rev.		.949:1
	Fan cutout type		Thermo-modulated-viscous coupling
	Bearing type		Double row ball
* Drive belts (indicate belt used by letter)	Fan		AB
	Generator or alternator		A
	Water Pump		B
	Power Steering		NA
	Air Conditioning		NA

* Drive Belt Dimensions	A	B	C	D	E	F	G	H	I	J	K
Angle of V	38°	42°									
Nominal length (SAE)	56.00	34.40									
Width		.380									

AMA Specifications—Passenger Car

MAKE OF CAR CORVETTE MODEL YEAR 1968 DATE ISSUED 10-15-67 REVISED (*)

MODEL 19400 427 Cu. In. V-8
430 HP Opt (L88)

ELECTRICAL – SUPPLY SYSTEM

Battery	Make and Model		Delco-Remy 1980087	
	Voltage Rtg. & Total Plates		12 volt-78 plate	
	SAE Designation & Amp. Hr. Rtg.		62 amp/hr @ 20 hr. rate	
	Location		Behind driver seat in stowage compartment	
Terminal grounded		Negative		
Generator or Alternator	Make		Delco-Remy	
	Model		1100696	
	Type and rating		Diode rectified 9-37 amps	
	Output at engine idle (neutral)		24 amps	
Ratio—Gen. to Cr's rev.		2.46:1		
Regulator	Make		Delco-Remy	
	Model		1119515	
	Type		Vibrator	
	Cutout relay	Closing voltage generator rpm	None	
		Reverse current to open	None	
	Regulated	Voltage	13.8-14.8 @ 85°F	
		Current	--	
Voltage test conditions	Temperature	Operating		
	Load	3-8 amperes		
	Other	None		

ELECTRICAL – STARTING SYSTEM

Starting Motor	Make		Delco-Remy	
	Model		1107365	
	Rotation (drive end view)		Clockwise	
Motor control	Switch (solenoid, manual)		Solenoid	
	Starting procedure		4-Spd- Place gearshift lever in neutral & depress clutch INITIAL START- Press accelerator to floor & release. Turn ignition to START, release as soon as engine starts.	
Motor Drive	Engagement type		Position shift solenoid	
	Pinion meshes (front, rear)		Rear	
	Number of teeth	Pinion	9	
		Flywheel	Manual	168
	Auto.		NA	
Flywheel tooth face width	Manual	.4100-.4220		
	Auto.	NA		

AMA Specifications—Passenger Car

MAKE OF CAR CORVETTE MODEL YEAR 1968 DATE ISSUED 10-15-67 REVISED (*)MODEL 19400

427 Cu. In. V-8

430 HP Opt. (L88)

ELECTRICAL - IGNITION SYSTEM

Type	Conventional - Std., Opt., N.A.		NA
	Transistorized - Std., Opt., N.A.		Standard
	Other (specify)		None
Coil	Make		Delco-Remy
	Model		1115287
	Amps	Engine stooped	4.0
		Engine idling	1.8
Distributor	Make		Delco-Remy
	Model		1111295
	Cent'fgal adv. in c/shaft degrees @ engine rpm (nominal)	Start (rpm)	1200
		Intermediate points deg. @ rpm	18 @ 1900
		Max. deg. @ rpm	30 @ 5000
	Vacuum adv. in c/shaft degrees @ in. Hg. (nominal)	Start (in. Hg.)	None
		Intermediate points, deg. @ in. Hg.	None
		Max. deg. in. Hg.	None
	Breaker gap (in.)		Magnetic
	Cam angle (deg.)		Pulse
Breaker arm tension (oz.)		Amplifier	
Timing	Crankshaft deg. @ rpm		12 BTC at idle
	Mark location		Torsional damper
Spark Plug	Make		AC Spark Plug
	Model		AC43N
	Thread (mm)		14
	Tightening torque (lb. ft.)		25
Gap		.033-.038	
Cable	Conductor type		Linen core impregnated with electrical conducting
	Insulation type		Rubber with neoprene jacket
	Spark plug protector		Hypalon jacket

ELECTRICAL - SUPPRESSION

Locations & type Non-metallic, high tension ignition

AMA Specifications—Passenger Car

MAKE OF CAR CORVETTE MODEL YEAR 1968 DATE ISSUED 10-15-67 REVISED (*)MODEL 19400 427 Cu. In. V-8
430 HP Opt. (L88)

ELECTRICAL -- INSTRUMENTS AND EQUIPMENT

Speed-ometer	Type	Dial
	Trip odometer (yes,no)	Yes
Charge indicator - type		Ammeter
Temperature indicator - type		Electric gauge
Oil pressure indicator - type		Bourdon tube gauge
Fuel indicator - type		Electric gauge
Other		Mechanical tachometer
Wind-shield wiper	Type - Standard	Electric two-speed
	Type - Optional	None
Wind-shield washer	Type - Standard	Push-button
	Type - Optional	None
Horn	Type	Vibrator
	Number used	Two
	Amp draw (each)	(Low note) 4.5-6.5 @ 12.5V. (Hi note) 4.2-6 @ 12.5V.

DRIVE UNITS -- CLUTCH (Manual Transmission)

Make & type		4-Speed Chevrolet, single dry disc. semi-centrifugal
Type pressure plate springs		Circular plate diaphragm, bent finger design
Total spring load (lb.)		2600-2800
of clutch driven discs		One
Clutch facing	Material	Premium grade woven type asbestos
	Outside & inside dia.	11.00 & 6.50
	Total eff. area (sq.in.)	123.70
	Thickness	.140 each
	Engagement cushioning method	Flat spring steel between cushions
Release bearing	Type & method of lubrication	Single row ball, packed and sealed
Torsional damping	Methods: springs, friction material	Coil, springs

AMA Specifications—Passenger Car

TYPE OF CAR CORVETTE MODEL YEAR 1968 DATE ISSUED 10-15-67 REVISED (*)

MODEL	19400	427 Cu. In. V-8 430 HP Opt (L88)
--------------	-------	-------------------------------------

DRIVE UNITS – TRANSMISSIONS

Manual 3-speed (std. or opt.)	Not available
Manual 4-speed (std. or opt.)	Optional
Manual with overdrive (std. or opt.)	Not available
Automatic (std. or opt.)	Not available

DRIVE UNITS – MANUAL TRANS.

Number of forward speeds	4 4-Speed		
Transmission ratios	In first	2.20	
	In second	1.64	
	In third	1.27	
	In fourth	1.00	
	In reverse	2.26	
Synchronous meshing, specify gears	All forward gears		
Shift lever location	Floor mounted		
Lubricant	Capacity (qt.)	3	
	Type recommended	Military spec. MIL-L-2105-B	
	SAE viscosity number	Summer	SAE 80
		Winter	SAE 80
		Extreme cold	SAE 80

DRIVE UNITS – MANUAL TRANS. W/OVERDRIVE

(For transmission data see manual transmission section)

Type (planetary or other)			
Manual lockout (yes, no)			
Downshift accelerator control (yes, no)			
Minimum cut-in speed	Not		
Gear ratio			
Lubricant	Capacity (qt.) (Overdrive only)	Available	
	Separate filler (yes, no)		
	Type recommended		
	SAE viscosity number	Summer	
		Winter	
	Extreme cold		

AMA Specifications—Passenger Car

MAKE OF CAR CORVETTE MODEL YEAR 1968 DATE ISSUED 10-15-67 REVISED (6)

MODEL 19400

DRIVE UNITS — AUTOMATIC TRANSMISSION - NOT AVAILABLE

Trade name	
Type describe	
Selector location	
List gear ratios Selector Pattern and indicate which are used in each selector position	
Max. upshift speed—drive range	
Max. kickdown speed—drive range	
Torque converter	Number of elements
	Max. ratio at stall
	Type of cooling (air, liquid)
	Nominal diameter
Lubricant	Capacity—refill (pt.)
	Type recommended
Special transmission features	

DRIVE UNITS — PROPELLER SHAFT

Number used		One
Type (straight tube, tube-in-tube, internal-external damper, etc.)		Straight tube
Outer diam. x length* x wall thickness	Manual 3-speed trans.	Not available
	Manual 4-speed trans.	2.00 x 29.90 x .095
	Overdrive transmission	Not available
	Automatic transmission	Not available

* Center to center of universal joints, or to centerline of rear attachment.

(Continued)

AMA Specifications—Passenger Car

TYPE OF CAR CORVETTE MODEL YEAR 1968 DATE ISSUED 10-15-67 REVISED (*)

MODEL 19400

DRIVE UNITS — PROPELLER SHAFT (cont.)

Inter-mediate bearing	Type (plain, anti-friction)	None
	Lubrication (fitting, prepack)	--
Slip Yoke	Type	Yoke
	Number of teeth	27
	Spline O.D.	1.1750
Universal joints	Make and Mfg. No.	Chevrolet, 3868728
	Number used	Two
	Type (ball and trunnion, cross)	Cross
	Rear attach. (u-bolt, clamp, etc.)	V-Belt
	Bearing	Type (plain, anti-friction)
Lubric. (fitting, prepack)		Prepack
Drive taken through (torque tube, ms, springs)		Torque control arms
Torque taken through (torque tube or arms, springs)		Torque control arms

DRIVE UNITS — AXLE

Type (front, rear)		Rear
Description		Semi-floating, overhung pinion gear
Limited Slip differential, type		Dual disc clutches
Drive Pinion Offset		1.5
No. of differential pinions		2
Pinion adjustment (shim, other)		None
Pinion bearing adj. (shim, other)		Shim
Wheel bearing type		Taper roller
Capacity (pt.)		3.7
Type recommended		Meeting Military Specs MIL-L-2105-B
Lubricant	SAE viscosity number	SAE 80
	Summer	SAE 80
	Winter	SAE 80
Extreme cold		SAE 80

AXLE RATIO TOOTH COMBINATIONS

(See page 3 for axle ratio usage)

Axle ratio		3.36	3.55	3.70	4.11	4.56
No. of teeth	Pinion	11	9	10	9	9
	Ring gear	37	32	37	37	41
Gear O.D.		8.375				

AMA Specifications—Passenger Car

NAME OF CAR CORVETTE MODEL YEAR 1968 DATE ISSUED 10-15-67 REVISED (*)

MODEL 19400

DRIVE UNITS—WHEELS

Type & material		Short spoke disc steel	
Rim (size & flange type)	Std.	15 x 7 JK	
	Opt.	None	
Attachment	Type (bolt or stud)	Stud	
	Circle diameter	4.75	
	Number and size	5 Hex nuts 7/16-20 UNF 2-B	

MODEL _____

DRIVE UNITS—TIRES

Standard	Size, ply rating, & ply		F 70 x 15-2 ply (4 ply rating)	
	Type (bias, radial, etc.)		Bias	
	Full rated Inflation Press.	Front	24	
		Rear	24	
	Rev./Mile at 50 MPH		776	
Optional	Size, ply rating, & ply		None	

BRAKES—PARKING

Type of control		Grip handle control	
Location of control		Center of floor console	
Operates on		Rear wheels	
If separate from service brakes	Type (internal or external)	Internal	
	Drum diameter	6.5	
	Lining size (length x width x thickness)	6.78 x 1.25 x .175	

AMA Specifications—Passenger Car

MAKE OF CAR CORVETTE MODEL YEAR 1968 DATE ISSUED 10-15-67 REVISED (*)MODEL 19400

BRAKES—SERVICE

Type (drum or disc)		Caliper disc, 4-wheel hydraulic		
Self adjusting (std., opt., N.A.)		Standard		
Power brake make & type (remote, int., etc.)	Std.	--		
	Opt.	Delco-Moraine vacuum power unit: integral		
Effective area (sq. in.)*		78.1		
Gross lining area (sq. in.)**		86.3		
Swept area (sq. in.)***		461.2		
Percent brake effectiveness—front		65		
Drum or Disc	Diameter (nominal)	Front	11.75 x 1.25	
		Rear	11.75 x 1.25	
	Type and material		Cast iron	
	Disc (vented or solid)		Vented	
No. pistons per caliper		4		
Wheel cylinder bore	Front	1.875		
	Rear	1.375		
Master Cylinder	Bore	1.00		
	Displacement distribution	Front %	65	
Rear %		35		
Proportioning valve	Type (proportion, delay, metering, other)	Check valve		
Pedal arc ratio		4.52		
Line pressure at 100 lb. pedal load		576		
Shoe clearance adjustment		Self-adjusting		
Brake lining	Drum or Disc		Disc	
	Bonded or riveted		Riveted	
	Front Wheel	Material		Woven asbestos
		Size (length x width x thickness)	Prim. or out-board	5.96 x 2.21 x .41
			Second. or in-board	5.96 x 2.21 x .41
		Segments per shoe		One
	Rear Wheel	Material		Woven asbestos
		Size (length x width x thickness)	Prim. or out-board	5.96 x 2.21 x .41
			Second. or in-board	5.96 x 2.21 x .41
		Segments per shoe		One

* Excludes rivet holes, grooves, chamfers, etc. ** Includes rivet holes, grooves, chamfers, etc.

*** Total swept area for four brakes. (Widest lining contact width for each brake x its contact circumference.)

AMA Specifications—Passenger Car

MAKE OF CAR CORVETTE MODEL YEAR 1968 DATE ISSUED 10-15-67 REVISED (*)

MODEL 19400

STEERING

Manual (std., opt., NA)		Standard	
Power (std., opt., NA)		--	
Adjustable steering wheel (tilt, swing, other)	Type and description (std., opt., NA)	Telescopic steering column; 3" adjustment	
		Optional	
Wheel diameter	Manual	16.0	
	Power	16.0	
Turning diameter (feet)	Outside front	Wall to wall (l. & r.)	
		Curb to curb (l. & r.)	
	Inside rear	Wall to wall (l. & r.)	
		Curb to curb (l. & r.)	
Outside whl. angle with inside whl. at 20°		18.47	
Manual	Gear	Type	Semi-reversible, recirculating ball nut
		Make	Saginaw
	Ratios	Gear	16.0:1
		Overall	20.2:1
No. wheel turns		3.4	
Power	Type (coaxial, linkage, etc.)		
	Make		Not
	Gear	Type	--
		Ratios	--
		Overall	Available
	Pump driven by		--
Number wheel turns		--	
Linkage	Type		Parallelogram
	Location (front or rear of wheels, other)		Rear
	Drag link (trans. or longit.)		None
	Tie rods (one or two)		Two
Steering Axis	Inclination at camber (deg.)		6-1/2 to 7-1/2
	Bearings (type)	Upper	Ball stud with non-metallic bearing surface
		Lower	Ball stud with non-metallic bearing surface
		Thrust	None
Whl. Align. (range at curb wt. & preferred)	Caster (deg.)		P1/2 to P1-1/2
	Camber (deg.)		P1/4 to P1-1/4 (a)
	Toe-in (outside track inches)		3/32 to 5/32 (a)
Steering spindle & joint type		Steering knuckle with spherical joint	
Wheel Spindle	Diameter	Inner bearing	1.2493-1.2498
		Outer bearing	.7492-.7497
	Thread size		3/4-20 NEF - 3 (Modified)
	Bearing type		Taper roller

(a) Rear wheel alignment: N 1-3/8 to N 3/8
Toe-In 1/32 to 3/32

AMA Specifications—Passenger Car

MAKE OF CAR CORVETTE MODEL YEAR 1968 DATE ISSUED 10-15-67 REVISED (*)
 MODEL 19400 12400

SUSPENSION – GENERAL

(See Supplement page for details on Air Suspension)

Provision for car leveling	Front stabilizer bar	
Provision for brake dip control	Mounting angle of front upper control arm	
Provision for acc. squat control	None	
Special provisions for car jacking	Front: 5" forward of front edge of door opening, under fram Rear: 3" forward of wheel opening, under frame.	
Shock absorber front & rear	Type	Direct, double acting hydraulic
	Make	Delco
	Piston dia.	1.00
Other special features		

SUSPENSION – FRONT

Type and description	Independent: SLA type with coil spring and concentric shock absorber, and spherically-jointed steering knuckle for each wheel	
Spring	Type	Coil
	Material	Steel alloy
	Size (coil design height & I.D. bar length x dia.)	9.99 x 3.80 138.75 x .618
	Spring rate (lb. per in.)	284
	Rate at wheel (lb. per in.)	
Stabilizer	Type (link, linkless, frameless)	Link
	Material & bar diameter	Steel .9375

SUSPENSION – REAR

Type and description	(A)	
Drive and torque taken through	Torque control arms	
Spring	Type	Multi-leaf
	Material	Chrome carbon steel
	Size (length x width, coil design height & I.D.; bar length & dia.)	46.36 x 2.25
	Spring rate (lb. per in.)	140
	Rate at wheel (lb. per in.)	123
	Mounting insulation type	Rubber mounted at differential; Vertical loading only at shaft
	If leaf	No. of leaves Shackle (comp. or tens.)
Stabilizer	Type (link, linkless, frameless)	Link
	Material	.562
Track bar type	None	

A - Full independent with fixed differential, transverse multi-leaf spring, lateral struts and universally-jointed axle shafts

AMA Specifications—Passenger Car

TYPE OF CAR CORVETTE MODEL YEAR 1968 DATE ISSUED 10-15-67 REVISED (*)

MODEL 19400

FRAME

Type and description (Separate frame, unitized frame, partially - unitized frame)	All welded, full length, ladder constructed frame with 5 crossmembers
---	---

BODY - MISCELLANEOUS INFORMATION	SPORT COUPE	CONVERTIBLE
----------------------------------	-------------	-------------

Drs. hinged (front, rr.)	Front doors	Front
Rear doors		None
Type of finish (lacquer, enamel, other)		Lacquer
Hood counterbalanced (yes, no)		No
Hood release control (internal, external)		Internal
Vehicle Ident. No. location	Left hand side on windshield garnish moulding	
Engine No. location	Front right side of cylinder block	
Theft protection - type	Warning buzzer sounds when key is left in "OFF" position with left front door open	
Vent window control method (crank, friction pivot)	Front	None
	Rear	None
5 Cushion type	Front	Bucket-polyurethane padding
	Rear	None
	3rd seat	None
Seat back type	Front	Bucket-polyurethane padding
	Rear	None
	3rd seat	None
Windshield glass type (i.e., single curved - laminated plate)	Curved-laminated plate	
Side glass type (i.e., curved - tempered plate)	Curved-tempered plate	
Backlight glass type (i.e., compound curved - tempered plate, three pieces)	Flat, tempered plate	Plastic (soft top) Curved plexiglass (aux. H.T.)
Windshield glass exposed surface area		
Side glass exposed surface area		
Backlight glass exposed surface area		
Total glass exposed surface area		



AMA Specifications—Passenger Car

The information contained herein is prepared, distributed by, and is solely the responsibility of the automobile manufacturing company to whose products it relates. Questions concerning these specifications should be directed to the manufacturer whose address is shown below. This uniform specification form was developed by the automobile manufacturing companies under the auspices of the Automobile Manufacturers Association.

MANUFACTURER Chevrolet Motor Division Owner Relations Department		CAR NAME CORVETTE	
MAILING ADDRESS 1077 Argonaut "A" G.M. Bldg. Detroit, Michigan 48202		MODEL YEAR 1968	ISSUED: 10-15-67 REVISED (•)

NOTES:

1. The Specifications herein are those in effect at date of compilation and are subject to change without notice by the manufacturer.
2. UNLESS OTHERWISE INDICATED:
 - a. Specifications apply to standard models without optional equipment. Significant deviations are noted.
 - b. Nominal design dimensions are used throughout these specifications.

TABLE OF CONTENTS

Car & Body Dimensions	1, 2	Drive Units	14	Suspensions	
Engine - Mechanical	4	Brakes	18, 19	Weights	
Electrical	12	Steering	20	Index	

BODY - TYPES AND STYLE NAMES -

Body type, number of passenger & style names; use manufacturer's code for series & body style.

	<u>327 Cu.In.</u>	<u>427 Cu.In.</u>	
	V8-300HP	V8-350HP	V8-390HP
	Standard	Opt(L79)	Opt(L79)
			Opt(L68)
			Opt(L71)
2-Door Sport Coupe, 2-Pass.			19437
2-Door Convertible, 2-Pass.			19467

AMA Specifications—Passenger Car

MAKE OF CAR CORVETTE MODEL YEAR 1968 DATE ISSUED 10/15/67 REVISED (*)

CAR AND BODY DIMENSIONS

See Pages 25, 26 for SAE Dimension Definitions

(All dimensions in inches unless otherwise indicated)

All dimensions to ground are for comparative purposes only and are shown with vehicle load of two passengers in front and three in rear, except where otherwise noted.

MODEL	19400	SAE Ref. No.	SPORT COUPE	CONVERTIBLE	
				SOFT TOP	HARDTOP
WIDTH					
Track - Front		W101		58.3	
Track - Rear		W102		59.0	
Maximum overall car width		W103		69.2	
Body width at No. 2 pillar		W117			
LENGTH					
Body "O" to front of dash		L 30			
Wheelbase		L101		98.0	
Overall car length		L103		182.1	
Overhang - front		L104		40.2	
Overhang - rear		L105		43.9	
Body upper structure length		L123	54.7		
Body "O" line to C of rear wheel		L127		72.0	
Body "O" line to w/s cowl point		L130		11.6	
HEIGHT					
Overall height		H101	47.8		
Cowl height		H114		26.6	
Deck height		H138			
Rocker panel - front	To ground			7.6	
	From front wheel C	H112			
Rocker panel - rear	To ground			7.6	
	From rear wheel C	H111			
Windshield slope angle		H122		57	
GROUND CLEARANCE					
Bumper to ground - front		H102		9.2	
Bumper to ground - rear		H104		12.3	
Angle of approach		H106		22	
Angle of departure		H107		21	
Ramp breakover angle		H147		22	
Min. running clearance (Specify)		H156		4.9 (Exhaust to ground)	

AMA Specifications—Passenger Car

MAKE OF CAR CORVETTE MODEL YEAR 1968 DATE ISSUED 10/15/67 REVISED (*)

CAR AND BODY DIMENSIONS

See Pages 25, 26 for SAE Dimension Definitions
(All dimensions in inches unless otherwise indicated)

MODEL	19400	SAE Ref. No.	SPORT COUPE	CONVERTIBLE	
				SOFT TOP	HARDTOP
FRONT COMPARTMENT					
Effective head room	H61	36.2	37.1	36.0	
Max. eff. leg room - accelerator	L34		43.0		
H Point to Heel point	H30		6.5		
H Point travel	L17		4.5		
Shoulder room	W 3		46.9		
Hip room	W 5		48.8		
Upper body opening to ground	H50		43.6		
REAR COMPARTMENT					
H Point couple distance	L50		--		
Effective head room	H63		--		
Min. effective leg room	L51		--		
H Point to Heel point	H31		--		
Min. knee room	L48		--		
Rear Compartment room	L 3		--		
Shoulder room	W 4		--		
Hip room	W 6		--		
Upper body opening to ground	H51		--		
LUGGAGE COMPARTMENT					
Usable luggage capacity	V 1				
Liftover height	H195				
Position of spare tire storage					
Method of holding lid open					
STATION WAGON - THIRD SEAT					
Shoulder Room	W85				
Hip room	W86				
Effective leg room	L86				NOT AVAILABLE
Effective head room	H86				
Seat facing direction					
STATION WAGON - CARGO SPACE					
Cargo length at floor - front seat	L202				
Cargo length at belt - front seat	L204				
Cargo width - wheelbase	W201				
Opening width at belt	W204				NOT AVAILABLE
Maximum cargo height	H201				
Rear opening height	H202				
Cargo volume index (cu. ft.) W4 x L204 x H201 1728	V2				

AMA Specifications—Passenger Car

MAKE OF CAR CORVETTE MODEL YEAR 1968 DATE ISSUED 10/15/67 REVISED (e)

POWER TEAMS

(Indicate whether standard or optional)

A B C D

MODEL AVAILABILITY	ENGINE					TRANSMISSION	AXLE RATIO ** (Std. first) (Indicate A/C ratio) *				
	Displ. cu. in.	Carburetor	Compr. Ratio	BHP RPM	Torque RPM						
ALL MODELS	327 Std.	One; 4-Bbl	10.0:1	300 @ 5000	360 @ 3400	2-Speed (2.54:1 low)	Base	3.36	3.08	--	--
						& 4-Speed* (2.52:1 low)	A/C	3.36	3.08		
						Turbo* Hyd-Mtc.	Base	3.08	--	--	--
						A/C	3.08	--	--	--	
	327 Opt. (L79)	One; 4-Bbl	11.0:1	350 @ 5800	360 @ 3600	4-Speed* (2.52:1 low)	Base	3.36	--	3.55	--
						A/C	3.36	--	3.55	--	
						4-Speed* (2.20:1 low)	Base	3.70	--	4.11	--
						A/C	3.70	--	4.11	--	
	427 Opt. (L36)	One; 4-Bbl	10.25:1	390 @ 5400	460 @ 3600	4-Speed* (2.52:1 low)	Base	3.08	--	3.36	
						A/C	3.08	--	3.36	--	
						4-Speed* (2.20:1 low)	Base	3.36	3.08	3.55	3.70
						A/C	3.36	3.08	3.55	3.70	
427 Opt. (L68)	Three; 2-Bbl	10.25:1	400 @ 5400	460 @ 3600	4-Speed* (2.52:1 low)	Base	3.08	--	3.36	--	
					A/C	3.08	--	3.36	--		
					4-Speed* (2.20:1 low)	Base	3.36	3.08	3.55	3.70	
					A/C	3.36	3.08	3.55	3.70		
427 Opt. (L71)	Three 2-Bbl	11.0:1	435 @ 5800	460 @ 4000	4-Speed* (2.20:1 low)	Base	3.55	3.36	3.70	4.11	
					A/C	Not available					

- A-Standard
- B-Economy
- C-Performance
- D-Special Purpose
- *-Optional

** -Positraction axles available optionally for 327 Cu. In. 3-Speed & 4-Speed combinations. All other engine-transmission axle combinations are available as positraction only.

AMA Specifications—Passenger Car

MAKE OF CAR	CORVETTE		MODEL YEAR	1968	DATE ISSUED	10/15/67	REVISED (*)
MODEL	19400	327 Cu. In. V-8		427 Cu. In. V-8			
		300 HP Standard	350 HP Opt. (L79)	390 HP Opt (L36)	400 HP Opt. (L68)	435 HP Opt. (L79)	

ENGINE—GENERAL

Type, no. cyls., valve arr.	90° OHV V-8				
Bore and stroke (nominal)	4.00 x 3.25		4.25 x 3.76		
Piston displacement, cu. in.	327		427		
Bore spacing (C to C)	4.4		4.84		
No. system (front to rear)	L. Bank	1-3-5-7			
	R. Bank	2-4-6-8			
Firing order	1-8-4-3-6-5-7-2				
Compres. ratio (nominal)	10.0:1	11.0:1	10.25:1	11.0:1	
Cylinder Head Material	Cast alloy iron				
Cylinder Block Material	Cast alloy iron				
Cyl. Sleeve-Wet, dry, none	None				
Number of mtg. points	Front	Two			
	Rear	One			
Engine installation angle	3°				
Taxable horsepower	51.2		57.8		
Publishing max. bhp* @ eng. RPM	300 @ 5000	350 @ 5800	390 @ 5400	400 @ 5400	435 @ 5400
Publishing max. torque* (lb. ft. @ RPM)	360 @ 3400	360 @ 3600	460 @ 3600	460 @ 3600	460 @ 4000
Recommended fuel regular - premium					

ENGINE—PISTONS

Material	Cst. al. alloy	(a)	Cast aluminum alloy	(a)	
Description and finish	Flat notched head	Domed head, valve cutout			
Weight (piston only) oz.	21.60	20.64	28.00	24.67	
Clearance (limits)	Top land	.0365 - .0455		.0265 - .0375	
	Skirt	Top	.0005 - .0011(b)		.0012 - .0018(d)
		Bottom	.0024 - .0030(c)		.0040 - .0045
Ring groove depth	No. 1 ring	.2217 - .2283		.2348 - .2413	
	No. 2 ring	.2217 - .2283		.2348 - .2413	
	No. 3 ring	.2038 - .2103		.2183 - .2248	
	No. 4 ring	None			

* Max. bhp (brake horsepower) and max. torque corrected to 60° F and 29.92 in. Hg atmospheric pressure.

- (a) Aluminum impact extruded
- (b) Measured 2.24 from top of piston
- (c) Measured 2.20 from top of piston
- (d) Measured 1.91 from top of piston
- (e) Measured 2.07 from top of piston

AMA Specifications—Passenger Car

MAKE OF CAR	CORVETTE		MODEL YEAR	1968	DATE ISSUED	10/15/67	REVISED (e)
			327 Cu. In. V-8		427 Cu. In. V-8		
MODEL	19400	300 HP Standard	350 HP Opt. (L79)	390 HP Opt. (L36)	400 HP Opt. (L68)	435 HP Opt. (L7)	

ENGINE - RINGS

Function (top to bottom)	No. 1, oil or comp.	Compression				
	No. 2, oil or comp.	Compression				
	No. 3, oil or comp.	Oil				
	No. 4, oil or comp.	None				
Compression	Description - Upper material, coating, etc.	Cast alloy iron; bbl. face; chrome plate on L30, Moly inlay on remainder				
	Lower	Cast alloy iron; chrome plate on L79 & L71, wear resistant ctng. or				
	Width	(a)	(b)	.0770-.0775 / remain		
	Gap	(c)		.010-.020		
Oil	Description - material, coating, etc.	Multi-piece (2 rails and one spacer expander) Rails-steel, chrome plated OD Expander-stainless steel				
	Width	.1870-.1890 (assembled)				
	Gap	.015-.055		.010-.030		
Expanders		In oil ring assembly				

ENGINE - PISTON PINS

Material	Chromium steel				
Length	2.990-3.010		2.930-2.950		
Diameter	.9270-.9273		.9895-.9898		
Type	Locked in rod, in piston, floating, etc.	Locked in rod			
	Bush- ing	In rod or piston	None		
	Material	--			
Clearance	In piston	.00015-.00025	.00045-.00055	.00025-.00035	.00030-.00035
	In rod	None			
Direction & amount offset in piston		(d)	On center	(d)	On center

ENGINE - CONNECTING RODS

Material	Drop forged steel		High alloy steel
Weight (oz.)	27.84		27.84
Length (center to center)	5.699-5.701		6.130-6.140
Bearing	Material & Type	Premium aluminum	
	Overall length	.797	.857
	Clearance (limits)	.0007-.0027	.0009-.0029
	End play	.009-.013	.016-.020

- (a) Upper .0775-.0780; lower .0770-.0775
- (b) Upper .0770-.0775; lower .0775-.0780
- (c) Upper .010-.020; lower .013-.025
- (d) Major thrust side .055-.065

AMA Specifications—Passenger Car

MAKE OF CAR CORVETTE MODEL YEAR 1968 DATE ISSUED 10/15/67 REVISED ^(a)

MODEL	19400	327 Cu. In. V-8		427 Cu. In. V-8		
		300 HP Standard	350 HP Opt. (L79)	390 HP Opt. (L36)	400 HP Opt. (L68)	425 HP Opt. (L7)

ENGINE - CRANKSHAFT		Cast nodular iron	Forged steel
---------------------	--	-------------------	--------------

Vibration damper type **Rubber mounted inertia**

End thrust taken by bearing (No.) **Five**

Crankshaft end play **.002 - .006** **.006 - .010**

Main bearing	Material & type		Premium aluminum except No. 5 is sintered copper nickel backed babbitt		
	Clearance		(a)	(b)	(c)
	Journal dia. and bearing overall length	No. 1	2.4502 x .752	2.7507 x .992	2.7505 x .9
		No. 2	2.4505 x .752	2.7507 x .992	2.7505 x .9
		No. 3	2.4505 x .752	2.7505 x .992	2.7505 x .9
		No. 4	2.4505 x .752	2.7505 x .992	2.7505 x .9
		No. 5	2.4507 x 1.177	2.7506 x 1.2525	2.7506 x 1.25
	No. 6		None		
No. 7		None			
Dir. & amt. cyl. offset		None			
Crankpin journal diameter		2.099 - 2.100	2.199 - 2.200		

ENGINE - CAMSHAFT

Location **In block above crankshaft**

Material **Cast alloy iron**

Bearings **Steel backed babbitt**

Number **5**

Gear or chain **Chain**

Crankshaft gear or sprocket material **Steel sprocket**

Type of Drive **Cast alloy iron** **Cast aluminum**

Timing chain	No. of links	46	50
	Width	.740	.740
	Pitch	.500	.500

ENGINE - VALVE SYSTEM

Hydraulic lifters (Std., opt., NA) **Standard** **N.A.**

Valve rotator, type (intake, exhaust) **None**

Rocker ratio **1.50:1** **1.70:1**

Operating tappet clearance (indicate hot or cold)	Intake	Zero	.024
	Exhaust	Zero	.028

(Continued)

- (a) No. 1, .0008 - .0020; No. 2, 3, & 4, .0008 - .0024; No. 5, .0015 - .0031
- (b) No. 1 & 2, .0010 - .0020; No. 3 & 4, .0013 - .0025; No. 5, .0015 - .0031
- (c) No. 1, 2, 3 & 4, .0013 - .0025; No. 5, .0015 - .0031

AMA Specifications—Passenger Car

MAKE OF CAR CORVETTE MODEL YEAR 1968 DATE ISSUED 10/15/67 REVISED ^(a)

MODEL	19400	327 Cu. In. V-8		427 Cu. In. V-8		
		300HP Standard	350HP Opt. (L79)	390HP Opt. (L36)	400HP Opt. (L68)	435HP Opt. (L71)

ENGINE - VALVE SYSTEM (cont.)

Timing (based on top of ramp points)	Intake	Opens (°BTC)	28°	40°	40°	44°	
		Closes (°ABC)	72°	86°	80°	97°	
Duration - deg.	280°	306°	300°	316°			
Exhaust	Opens (°BBC)	78°	88°	88°	86°		
	Closes (°ATC)	30°	38°	32°	36°		
	Duration - deg.	288°	306°	300°	302°		
Valve opening overlap		58°	78°	72°	80°		
Material		Alloy steel; aluminized face; also chrome flash stem on L71 & L79					
Overall length		4.870 - 4.889		5.215 - 5.235		5.204-5.22	
Actual overall head dia.		1.935-1.945	2.017-2.023	2.060 - 2.070		2.185-2.19	
Angle of seat & face		46° (seat) 45° (face)					
Seat insert material		None					
Stem diameter		.3410-.3417		.3715-.3722			
Stem to guide clearance		.0010-.0027					
Lift (@ zero lash)		.3900	.4472	.4614		.5197	
Intake	Outer spring press. & length	Valve closed (lb.@in.)	76-84 @ 1.70		94-106 @ 1.88		
		Valve open (lb.@in.)	194-206 @ 1.25		303-327 @ 1.38		
	Inner spring press. & length	Valve closed (lb.@in.)	Spring damper				
		Valve open (lb.@in.)	Spring damper				
Material		High alloy steel; aluminized face; also chrome flash stem on L7					
Overall length		4.913-4.933	4.891-4.910	5.345-5.365 / & L79			
Actual overall head dia.		1.495-1.505	1.595-1.605	1.715-1.725			
Angle of seat & face		46° (seat) 45° (face)					
Seat insert material		None					
Stem diameter		.3410-.3417		.3713-.3720			
Stem to guide clearance		.0010-.0027		.0015-.0032			
Lift (@ zero lash)		.4100	.4472	.4800		.5197	
Exhaust	Outer spring press. & length	Valve closed (lb.@in.)	76-84 @ 1.70		94-106 @ 1.88		
		Valve open (lb.@in.)	194-206 @ 1.25		303-327 @ 1.38		
	Inner spring press. & length	Valve closed (lb.@in.)	Spring damper				
		Valve open (lb.@in.)	Spring damper				

ENGINE - LUBRICATION SYSTEM

Type of lubrication (splash, pressure, nozzle)	Main bearings	Pressure
	Connecting rods	Pressure
	Piston pins	Splash
	Camshaft bearings	Pressure
	Tappets	Pressure
	Timing gear or chain	Centrifugally oiled from front camshaft bearing
	Cylinder walls	Pressure; jet cross sprayed

(Continued)

AMA Specifications—Passenger Car

MAKE OF CAR CORVETTE MODEL YEAR 1968 DATE ISSUED 10/15/67 REVISED (e)
 MODEL 19400 327 Cu. In. V-8 427 Cu. In. V-8
 300 HP Standard | 350 HP Opt. (L79) | 390 HP Opt. (L36) | 400 HP Opt. (L68) | 435 HP Opt. (L79)

ENGINE - LUBRICATION SYSTEM (cont.)

Oil pump type		Gear
Normal oil pressure (lb. engine rpm)(A)	30-45 PSI @ 1500	50-75 PSI @ 2000
Oil press. sending unit (elect. or mech.)		Electric
Type oil intake (floating, stationary)		Stationary
Oil filter system (full flow, part., other)		Full flow
Filter replacement (element, complete)		Element
Capacity of c/case, less filter-refill (qt.)	4	5
Oil grade recommended (SAE viscosity and temperature range)	32° F and above - SAE 20W, SAE 10W-30 0° F to 32° F* - SAE 10W or SAE 10W-30 Below 0° F - SAE 5W or SAE 5W-20 *(SAE 5W-30 may be used at temperatures below fr	
Engine Service Reqmt. (MM, MS, etc.)		MS or DG

ENGINE - EXHAUST SYSTEM

Type (single, single with cross-over, dual, other)		Dual
Muffler No. & type (reverse flow, straight thru, separate resonator)		Two, reverse flow
Exhaust pipe dia. (O.D., wall thick.)	Branch	2.50 x .072-.092
	Main	2.50 x .084-.104 (laminated)
Tail pipe dia. (O.D. & wall thickness)		2.62 x .062-.072

ENGINE - CRANKCASE VENTILATION SYSTEM

Type (ventilates to atmos., induction system, other)	Standard	Induction system
	Optional	
Control Unit	Make and model	AC Spark Plug 6424251 (327 cu. in); 6424250 (396 & 427 c
	Location	Left front of rocker cover
	Energy source (manifold vacuum, carburetor air stream, other)	Manifold vacuum
	Control method (variable orifice, fixed orifice, other)	Variable orifice
Complete system	Discharges (to intake manifold, carb. air intake, air cleaner intake, other)	Intake manifold
	Air inlet (breather cap, carburetor air cleaner, other)	Carburetor air cleaner
	Flame arrester (screen, check valve, other)	Screen

A-Bench test - no flow conditions

AMA Specifications—Passenger Car

MAKE OF CAR CORVETTE MODEL YEAR 1968 DATE ISSUED 10/15/67 REVISED ^(a)

MODEL	19400	327 Cu. In. V-8		427 Cu. In. V-8	
		300 HP Standard	350 HP Opt. (L79)	390 HP Opt. (L36)	400 HP Opt. (L68)

ENGINE - EXHAUST EMISSION CONTROL

Man.	Auto.	Manual	Man.	Auto.	Man.	Auto.	Manual
------	-------	--------	------	-------	------	-------	--------

Type (Air injection, engine modifications, other) **MANUAL TRANSMISSION - Air injection reactor equipment**
AUTOMATIC TRANSMISSION - Controlled combustion system

Air Injection Pump *	Type	Semi-articulated vane type						
	Displacement	19.3						
	Drive ratio	1.15:1						
	Drive type	Crankshaft pulley						
	Relief valve (type)	Diverter valve			Pressure (plate type)			
Filter (describe)	Centrifugal air cleaner							

Air Injection System *	Air distribution (head, manifold, etc.)	Manifold						
	Point of entry	Exhaust ports						
	Injection tube I.D.	.2565						
	Check valve type	Pressure (plate type)						
Backfire protection (type)	Diverter valve							

Carburetor	Make	Rochester							
	Model	(a)	(b)	7028209	(c)	(d)	(e)	(f)	(c)
	Barrel size								
	Idle speed	Drive	-	600	-	-	600	-	600
	Neutral	700	-	750	700	-	750	-	750
Idle A/F mixture	Not specified								

Distributor	Aux. Adv. Systems (type)	None							
	Make	Delco-Remy							
	Model	1111194		1111438		1111293		1111296	
	Cent'gal adv. in crank degrees @ eng. rpm	Start (rpm)	900		950		900		900
		Intermed. points deg. @ rpm	15@1500		20@1800		17@2000		None
	Max. deg. @ rpm	30@5100		30@4700		32@5000		30@3800	
	Vacuum adv. in crank degrees @ eng. rpm	Start (in Hg)	6.00		6.00		7.00		8.00
		Intermed. points deg. @ in. Hg	None						
Max. deg. @ in.		15 @ 12		15 @ 15.5		12 @ 12		15 @ 15.5	
Vacuum Source	Carburetor								

Timing - Crank degrees @ rpm **4BTC at idle**

Cooling System (describe changes) **None**

Exhaust System (describe changes) **None**

* - Used with manual transmissions only.

- | | | |
|-------------|-------------|--|
| (a) 7028207 | (c) 7028209 | (e) 3925517 Primary; 3902353 Secondary |
| (b) 7028208 | (d) 7028216 | (f) 3925516 Primary; 3902353 Secondary |

AMA Specifications—Passenger Car

MAKE OF CAR CORVETTE MODEL YEAR 1968 DATE ISSUED 10/15/67 REVISED ^(a)

MODEL	19400	327 Cu. In. V-8		427 Cu. In. V-8		
		300 HP Standard	350 HP Opt. (79)	390 HP Opt. (L36)	400 HP Opt. (L68)	435 H Opt. (L

ENGINE—FUEL SYSTEM

(See supplemental page for Details of Fuel Injection, Supercharger, etc. if used)

Induction type: Carburetor, fuel injection, supercharger.		Carburetor				
Fuel Tank	Refill capacity (U.S. gals.)	20 (approximately)				
	Filler location	Center at rear deck				
Fuel Pump	Type (elec. or mech.)	Mechanical				
	Locations	Lower right front of engine				
	Pressure range	5.00 - 6.50 PSI				
Vacuum booster (std., optional, none)		None				
Fuel Filter	Type	Fine mesh plastic strainer in gas tank and paper filter in carburetor inlet				
	Locations	Automatic				
Carburetor	Choke type	Exhaust				
	Intake manifold heat control (exhaust or water)	Automatic				
	Air cleaner type	Standard	Oil-wetted paper element		Polyurethane	
		Optional				
	Idle speed (spec. neutral or drive)	Manual	700	750	700	750
		Automatic	600	NA	600	NA
	Idle A/F mix.					

CARBURETOR SUPPLEMENTARY INFORMATION

Model Usage	Engine Displ.	Transmission	Carburetors		No. Used and Type	Bore Size	
			Make	Model			
19400	327 300 hp	3-spd & 4-spd	Rochester	7028207	One; 4-Bbl down-draft	1.38 (prim) 2.25 (sec)	
		Turb Hyd-Mtc.	Rochester	7028208			
	4-Speed	Rochester	7028219				
	327 350 hp	4-Speed	Rochester	7028209			
	427 390 hp	4-Speed	Rochester	7028209			
		Turb Hyd-Mtc.	Rochester	7028216			
	427 400 hp	4-Speed	Holley	3925517 (primary) 3902353 (secondary)		Three; 2-Bbl (1-prim) (2-sec)	1.50 (prim) 1.75 (seco)
				Turbo Hydra-Matic	Holley		
	427 435 hp	4-Speed	Holley				

AMA Specifications—Passenger Car

MAKE OF CAR CORVETTE MODEL YEAR 1968 DATE ISSUED 10/15/67 REVISED ^(a)

MODEL 19400 327 Cu. In. V-8 427 Cu. In. V-8
 300 HP Standard 350 HP Opt. (L79) 390 HP Opt. (L36) 400 HP Opt. (L68) 435 HP Opt. (L71)

ENGINE - COOLING SYSTEM

Type system (pressure, pressure vented, atmospheric, other)	Pressure with surge tank		Pressure			
Radiator cap relief valve pressure	15 ± 1 PSI					
Circulation thermostat	Type (choke, bypass)	Choke				
	Starts to open at (°F)	192°-198°				
Water pump	Type (centrifugal, other)	Centrifugal				
	GPM @ 1000 pump rpm	57 @ 4400	82 @ 5200			
	Number of pumps	One				
	Drive (V-belt, other)	V-Belt				
	Bearing type	Double row ball				
By-pass recirculation type (inter., ext.)	Internal	External				
Radiator core type (cellular, tube and fin, other)	Cross flow					
Cooling system capacity	With heater (qt.)	15	22			
	Without heater (qt.)	14	21			
	Opt. equipment-specify (qt.)					
Water jackets full length of cyl. (yes, no)	Yes					
Water all around cylinder (yes, no)	Yes					
Radiator hose	Lower	Number and type (molded, straight)	One, molded			
		Inside diameter	1.75	1.88		
	Upper	Number and type (molded, straight)	One, molded			
		Inside diameter	1.50			
	By-pass	Number and type (molded, straight)	None	One, molded		
		Inside diameter	None	.725-.765		
Fan	Number of blades & spacing	5-staggered				
	Diameter	17.50				
	Ratio-fan to crankshaft rev.	.949:				
	Fan cutout type	Thermo-modulated-viscous coupling				
	Bearing type	Double row ball				
*Drive belts (indicate belt used by letter)	Fan	A	EF	JF		
	Generator or alternator	A	E	J		
	Water Pump	A	EF	JF		
	Power Steering	B	G	G	G	NA
	Air Conditioning	C	H	K	K	NA
	Air Injection Pump	D	I	I	I	I

* Drive Belt Dimensions	A	B	C	D	E	F	G	H	I	J	K
Angle of V	←				38°-42°	→					
Nominal length (SAE)	53.25	36.25	57.50	34.00	54.00	34.40	45.00	56.75	33.50	56.00	45.7
Width	←				.380	→					

AMA Specifications—Passenger Car

MAKE OF CAR	CORVETTE	MODEL YEAR	1968	DATE ISSUED	10/15/67	REVISED (*)
MODEL	19400	327 Cu. In. V-8	300 HP Standard	350 HP Opt. (L79)	390 HP Opt. (L36)	427 Cu. In. V-8 400 HP Opt. (L68) 435 HP Opt. (L7)

ELECTRICAL – SUPPLY SYSTEM

Battery	Make and Model	Delco-Remy 1980087					
	Voltage Rtg. & Total Plates	12 volt-78 plate					
	SAE Designation & Amp. Hr. Rtg.	62 amp/hr @ 20 hr. rate					
	Location	Behind driver seat in stowage compartment					
	Terminal grounded	Negative					
Generator or Alternator	Make	Delco-Remy					
	Model	1100696					
	Type and rating	Diode rectified 9-37 amps.					
	Output at engine idle (neutral)	13 amps	22 amps	16 amps	24 amp		
	Ratio-Gen. to Cr/s rev.	2.46:1					
Regulator	Make	Delco-Remy					
	Model	1119515					
	Type	Vibrator					
	Cutout relay	Closing voltage generator rpm	None				
		Reverse current to open	None				
	Regulated	Voltage	13.8-14.8 @ 85° F				
		Current	---				
Voltage test conditions	Temperature	Operating					
	Load	3-8 amperes					
	Other	None					

ELECTRICAL – STARTING SYSTEM

Starting Motor	Make	Delco-Remy					
	Model	1108361		1107365			
	Rotation (drive end view)	Clockwise					
Motor control	Switch (solenoid, manual)	Solenoid					
	Starting procedure	3-Spd & 4-Spd- Place gearshift lever in neutral and depre AUTOMATIC- Place control lever in "N" or "P" position /c INITIAL START- Press accelerator to floor and release. ignition to START, release as soon as engine starts.					
Motor Drive	Engagement type	Position shift solenoid					
	Pinion meshes (front, rear)	Rear					
	Number of teeth	Pinion	9				
		Flywheel	Manual	153		168	
	Flywheel tooth face width	Auto.	153	NA	168	NA	
Manual		.4010-.4130		.4100-.4220			
	Auto.	.4010-.4130	NA	.4100-.4220	NA		

AMA Specifications—Passenger Car

MAKE OF CAR CORVETTE MODEL YEAR 1968 DATE ISSUED 10/15/67 REVISED ^(a)

MODEL	<u>19400</u>	327 Cu. In. V-8		427 Cu. In. V-8		
		300 HP Standard	350 HP Opt. (L79)	390 HP Opt. (L36)	400 HP Opt. (L68)	435 HP Opt. (L7)

ELECTRICAL - IGNITION SYSTEM

Type	Conventional - Std., Opt., N.A.		Standard		NA	
	Transistorized - Std., Opt., N.A.		NA	Optional		Standard
	Other (specify)		None			
Coil	Make		Delco-Remy			
	Model		1115270	1115287		
	Amps	Engine stopped	4.0			
		Engine idling	1.8			
Distributor	Make		Delco-Remy			
	Model		1111194	1111438	1111293	1111296
	Cent'gal adv. in c/shaft degrees@ engine rpm (nominal)	Start (rpm)	900	950	900	900
		Intermediate points deg.@rpm	15@1500	20@1800	17@2000	None
		Max. deg.@rpm	30@5100	30@4700	32@5000	30@5800
	Vacuum adv. in c/shaft degrees@ in. Hg. (nominal)	Start (in. Hg.)	6.00	6.00	7.00	8.00
		Intermediate points, deg.@in. Hg.				
		Max. deg. in. Hg.	15 @ 12	15 @ 15.5	12 @ 12	15 @ 15.5
	Breaker gap (in.)		.019			Magnetic
	Cam angle (deg.)		28-32			Pulse
Breaker arm tension (oz.)		19-23	28-32		amplifier	
Timing	Crankshaft deg.@rpm		4BTC at idle			
	Mark location		Torsional damper			
Spark Plug	Make		AC Spark Plug			
	Model		AC44	AC43N		
	Thread (mm)		14			
	Tightening torque (lb. ft.)		25			
	Gap		.033-.038			
Cable	Conductor type		Linen core impregnated with electrical conducting			
	Insulation type		Rubber with neoprene jacket			
	Spark plug protector		Hypalon jacket			

ELECTRICAL - SUPPRESSION

Locations & type	Non-metallic, high tension ignition
------------------	-------------------------------------

AMA Specifications—Passenger Car

MAKE OF CAR CORVETTE MODEL YEAR 1968 DATE ISSUED 10/15/67 REVISED ^(a)

MODEL	19400	327 Cu. In. V-8		427 Cu. In. V-8		
		300 HP Standard	350 HP Opt. (L79)	390 HP Opt. (L36)	400 HP Opt. (L68)	435 HP Opt. (L71)

ELECTRICAL - INSTRUMENTS AND EQUIPMENT

Speedometer	Type	Dial
	Trip odometer (yes,no)	Yes
Chdgtg indicator - type		Ammeter
Temperature indicator - type		Electric gauge
Oil pressure indicator - type		Bourdon tube gauge
Fuel indicator - type		Electric gauge
Other		Mechanical tachometer
Windshield wiper	Type - Standard	Electric two-speed
	Type - Optional	None
Windshield washer	Type - Standard	Push-button
	Type - Optional	None
Horn	Type	Vibrator
	Number used	Two
	Amp draw (each)	(low note) 4.5-6.5 @ 12.5V. (Hi note) 4.2-6 @ 12.5V.

DRIVE UNITS - CLUTCH (Manual Transmission)

Make & type	3 & 4-Spd	4-Speed
	Chevrolet, single dry disc, semi-centrifugal	
Type pressure plate springs	Circular plate diaphragm, bent finger design	
Total spring load (lb.)	2100-2300	2300-2600
No. of clutch driven discs	One	
	Premium grade woven type asbestos	
Clutch facing	Outside & inside dia.	10.34 & 6.50
	Total eff. area (sq.in.)	101.54
	Thickness	.135 each
	Engagement cushioning method	Flat spring steel between cushions
Release bearing	Type & method of lubrication	Single row ball, packed and sealed
Torsional damping	Methods: springs, friction material	Coil springs

AMA Specifications—Passenger Car

MAKE OF CAR	CORVETTE	MODEL YEAR	1968	DATE ISSUED	10/15/67	REVISED (*)
MODEL	327 Cu. In. V-8		427 Cu. In. V-8			
	300 HP Standard	350 HP Opt. (L79)	390 HP Opt. (L36)	400 HP Opt. (L68)	435 HP Opt. (L71)	

DRIVE UNITS – TRANSMISSIONS

Manual 3-speed (std. or opt.)	Standard available with 327 Cu. In. 300 HP only
Manual 4-speed (std. or opt.)	Optional
Manual with overdrive (std. or opt.)	Not available
Automatic (std. or opt.)	Turbo Hydra-Matic optional with 300 HP (std) 390 HP (L36) & 400 HP (L68) only

DRIVE UNITS – MANUAL TRANS.

		3-Speed(a)	4-Speed(b)	4-Speed(c)	
Number of forward speeds		3	4	4	
Transmission ratios	In first	2.54:1	2.52:1	2.20:1	
	In second	1.50:1	1.88:1	1.64:1	
	In third	1.00:1	1.47:1	1.27:1	
	In fourth	--	1.00:1	1.00:1	
	In reverse	2.63:1	2.59:1	2.26:1	
Synchronous meshing, specify gears		All forward gears			
Shift lever location		Floor mounted			
Lubricant	Capacity (pt.)	3			
	Type recommended	Meeting Military specs. MIL-L-2105B			
	SAE viscosity number	Summer	SAE 80		
		Winter	SAE 80		
Extreme cold		SAE 80			

DRIVE UNITS – MANUAL TRANS. W/OVERDRIVE

(For transmission data see manual transmission section)

Type (planetary or other)			
Manual lockout (yes, no)		NOT	
Downshift accelerator control (yes, no)			
Minimum cut-in speed		AVAILABLE	
Gear ratio			
Lubricant	Capacity (pt.) (Overdrive only)		
	Separate filler (yes, no)		
	Type recommended		
	SAE viscosity number	Summer	
		Winter	
Extreme cold			

- (a) Available with 327 Cu. In. 300 HP (Std.) only
 (b) Available with all engine combinations except 427 Cu. In. 435 HP (L71)
 (c) Available with all engine combinations except 327 Cu. In. 300 HP (Std.)

AMA Specifications—Passenger Car

MAKE OF CAR CORVETTE MODEL YEAR 1968 DATE ISSUED 10/15/67 REVISED ^(a)

MODEL	<u>19400</u>	<u>327 Cu.In.</u>	<u>427 Cu.In.</u>
DRIVE UNITS—AUTOMATIC TRANSMISSION			
Available with 327 Cu.In. 300 HP (Std.) & 427 Cu.In. 390 HP (L36) & 400 HP (L68) only			
Trade name	Turbo Hydra-Matic		
Type describe	Torque converter with planetary gears		
Selector location	Lever (floor mounted)		
List gear ratios Selector Pattern and indicate which are used in each selector position	P - Park R - 2.08 N - Neutral D - 2.48-1.48-1.00 L ₂ - 2.48-1.48 L ₁ - 2.48		
Max. upshift speed—drive range	51(1-2); 95(2-3)	51(1-2); 90(2-3)	
Max. kickdown speed—drive range	44(2-1); 88(3-2)	40(2-1); 84(3-2)	
Torque converter	Number of elements	3	
	Max. ratio at stall	2.30	2.04
	Type of cooling (air, liquid)	Water	
Lubricant	Nominal diameter	12.20	
	Capacity—refill (pt.)	8	
	Type recommended	A suffix A	
Special transmission features			

DRIVE UNITS—PROPELLER SHAFT

Number used	One		
Type (straight tube, tube-in-tube, internal-external damper, etc.)	Straight tube		
Outer diam. x length* x wall thickness	Manual 3-speed trans.	2.00 x 29.90 x .095	
	Manual 4-speed trans.	2.00 x 29.90 x .095	
	Overdrive transmission	Not available	
	Automatic transmission	2.00 x 29.50 x .095	

* Center to center of universal joints, or to centerline of rear attachment.

(Continued)

AMA Specifications—Passenger Car

MAKE OF CAR CORVETTE MODEL YEAR 1968 DATE ISSUED 10/15/67 REVISED (*)

MODEL

DRIVE UNITS — PROPELLER SHAFT (cont.)

Inter-mediate bearing	Type (plain, anti-friction)	None
	Lubrication (fitting, prepack)	---
Slip Yoke	Type	Yoke
	Number of teeth	27
	Spline O.D.	1.1750
Universal joints	Make and Mfg. No.	Chevrolet, 3868728
	Number used	Two
	Type (ball and trunnion, cross)	Cross
	Rear attach. (u-bolt, clamp, etc.)	V-Belt
	Bearing	Type (plain, anti-friction)
Lubric. (fitting, prepack)		Prepack
Drive taken through (torque tube or arms, springs)		Torque control arms
Torque taken through (torque tube or arms, springs)		Torque control arms

DRIVE UNITS — AXLE

Type (front, rear)		Rear
Description		Semi-floating, overhung pinion gear
Limited Slip differential, type		Dual disc clutches
Drive Pinion Offset		1.5
No. of differential pinions		2
Pinion adjustment (shim, other)		None
Pinion bearing adj. (shim, other)		Shim
Wheel bearing type		Taper roller
Capacity (pt.)		3.7
Type recommended		Meeting Military Specs MIL-L-2105-B
Lubricant	SAE vis. Summer	SAE 80
	SAE vis. Winter	SAE 80
	SAE vis. Extreme cold	SAE 80

AXLE RATIO .TOOTH COMBINATIONS

(See page 3 for axle ratio usage)

Axle ratio		2.73	3.08	3.36	3.55	3.70	4.11
No. of teeth	Pinion	15	12	11	9	10	9
	Ring gear	41	37	37	32	37	37
Ring Gear O.D.		8.375					

AMA Specifications—Passenger Car

The information contained herein is prepared, distributed by, and is solely the responsibility of the automobile manufacturing company to whose products it relates. Questions concerning these specifications should be directed to the manufacturer, whose address is shown below. This uniform specification form was developed by the automobile manufacturing companies under the auspices of the Automobile Manufacturers Association.

MANUFACTURER Chevrolet Motor Division General Motors Corporation	CAR NAME CORVETTE
MAILING ADDRESS Chevrolet Owner-Relation Dept. 1000 ...	MODEL YEAR 1968
	ISSUED: 10-15-67 REVISED (e)

NOTES:

- The Specifications herein are those in effect at date of compilation and are subject to change without notice by the manufacturer.
- UNLESS OTHERWISE INDICATED:
 - Specifications apply to standard models without optional equipment; Significant deviations are noted.
 - Nominal design dimensions are used throughout these specifications.

TABLE OF CONTENTS

Car & Body Dimensions 1,2	Drive Units 14	Suspensions 21
Engine - Mechanical 4	Brakes 18, 19	Weights 24
Electrical 12	Steering 20	Index 27

BODY - TYPES AND STYLE NAMES -

Body type, number of passenger & style names; use manufacturer's code for series & body style.

	427 Cu. In.
	V-8 430 HP
	Opt (L88)
2-Door Sport Coupe, 2-Pass.	19437
2-Door Convertible, 2-Pass.	19467

FILE COPY - DO NOT REMOVE
OWNER RELATIONS DEPARTMENT

AMA Specifications—Passenger Car

MAKE OF CAR CORVETTE MODEL YEAR 1968 DATE ISSUED 10-15-67 REVISED ^(*)

CAR AND BODY DIMENSIONS

See Pages 25, 26 for SAE Dimension Definitions

(All dimensions in inches unless otherwise indicated)

All dimensions to ground are for comparative purposes only and are shown with vehicle load of two passengers in front and three in rear, except where otherwise noted.

MODEL	19400	SAE Ref. No.	SPORT COUPE		CONVERTIBLE	
					SOFT TOP	HARDTOP
WIDTH						
Track - Front		W101			58.3	
Track - Rear		W102			59.0	
Maximum overall car width		W103			69.2	
Width at No. 2 pillar		W117				
LENGTH						
Body "O" to front of dash		L 30				
Wheelbase		L101			98.0	
Overall car length		L103			182.1	
Overhang - front		L104			40.2	
Overhang - rear		L105			43.9	
Body upper structure length		L123	54.7			
Body "O" line to ϵ of rear wheel		L127			72.0	
Body "O" line to w/s cowl point		L130			11.6	
HEIGHT						
Overall height		H101	47.8			
Cowl height		H114			26.6	
Deck height		H138				
Rocker panel - front	To ground	H112			7.6	
	From front wheel ϵ					
Rocker panel - rear	To ground	H111			7.6	
	From rear wheel ϵ					
Windshield slope angle		H122			57	
GROUND CLEARANCE						
Bumper to ground - front		H102			9.2	
Bumper to ground - rear		H104			12.3	
Angle of approach		H106			22	
Angle of departure		H107			21	
Ramp breakover angle		H147			22	
Min. running clearance (Specify)		H156			4.9 (Exhaust to ground)	

AMA Specifications—Passenger Car

MAKE OF CAR CORVETTE MODEL YEAR 1968 DATE ISSUED 10-15-67 REVISED ^(*)

CAR AND BODY DIMENSIONS

See Pages 25, 26 for SAE Dimension Definitions
(All dimensions in inches unless otherwise indicated)

MODEL	19400	SAE Ref. No.	SPORT COUPE	CONVERTIBLE	
				SOFT TOP	HARDTOP
FRONT COMPARTMENT					
Effective head room	H61	36.2	37.1	36.0	
Max. eff. leg room - accelerator	L34		43.0		
H Point to Heel point	H30		6.5		
H Point travel	L17		4.5		
Shoulder room	W 3		46.9		
Hip room	W 5		48.8		
Upper body opening to ground	H50		43.6		
REAR COMPARTMENT					
H Point couple distance	L50		--		
Effective head room	H63		--		
Min. effective leg room	L51		--		
H Point to Heel point	H31		--		
Min. knee room	L48		--		
Rear Compartment room	L 3		--		
Shoulder room	W 4		--		
Hip room	W 6		--		
Upper body opening to ground	H51		--		
LUGGAGE COMPARTMENT					
Usable luggage capacity	V 1				
Liftover height	H195				
Position of spare tire storage					
Method of holding lid open					
STATION WAGON - THIRD SEAT					
Shoulder Room	W85				
Hip room	W86				
Effective leg room	L86		NOT AVAILABLE		
Effective head room	H86				
Seat facing direction					
STATION WAGON - CARGO SPACE					
Cargo length at floor - front seat	L202				
Cargo length at belt - front seat	L204				
Cargo width - wheelbase	W201				
Opening width at belt	W204		NOT AVAILABLE		
Maximum cargo height	H201				
Rear opening height	H202				
Cargo volume index (cu. ft.)	V2				
<small>W4 x L204 x H201</small>					
<small>1728</small>					

AMA Specifications—Passenger Car

MAKE OF CAR CORVETTE MODEL YEAR 1968 DATE ISSUED 10-15-67 REVISED (*)

POWER TEAMS

(Indicate whether standard or optional)

MODEL AVAILABILITY	ENGINE					TRANSMISSION	AXLE RATIO * (Std. first) (Indicate A C ratio)			
	Displ. cu. in.	Carburetor	Compr. Ratio	BHP RPM	Torque RPM		A	B	C	D
19400	427 430 HP	4-bbl	12.5:1	430 @ 4600	485 @ 4000	4-Speed * (2.20:1 low)	3.36	3.08	3.55	3.70 4.11 4.56

- A-Standard
- B-Economy-Optional
- C-Performance-Optional
- D-Special Purpose-Optional

*-All engine-axle combinations are available as positraction only.

AMA Specifications—Passenger Car

MAKE OF CAR CORVETTE MODEL YEAR 1968 DATE ISSUED 10-15-67 REVISED (*)
 MODEL 19400 427 Cu. In. V-8
 430 HP Opt. (L88)

ENGINE - GENERAL

Type, no. cyls., valve arr.	90° OHV V-8	
Bore and stroke (nominal)	4.25 x 3.76	
Piston displacement, cu. in.	427	
Bore spacing (€ to €)	4.84	
No. system	L. Bank	1-3-5-7
(front to rear)	R. Bank	2-4-6-8
Firing order	1-8-4-3-6-5-7-2	
Compression ratio (nominal)	12.5:1	
Valve Head Material	Aluminum alloy	
Block Material	Cast alloy iron	
Lubrication	Wet, dry, none	
	None	
Number of mtg. points	Front	Two
	Rear	One
Engine installation angle	3°	
Taxable horsepower	Di ² xNo. Cyl. 2.5	57.8
Publishing max. bhp* @ eng. RPM	430 @ 4600	
Publishing max. torque* (lb. ft. @ RPM)	485 @ 4000	
Recommended fuel	Regular - premium	

ENGINE - PISTONS

Material	Aluminum impact extruded		
Description and finish	Domed head, valve cutout		
Weight (piston only) oz.	28.99		
Clearance limits	Top land	.0316-.0384	
	Skirt	Top	.0058-.0066 (a)
		Bottom	--
Ring groove depth	No. 1 ring	.2373-.2437	
	No. 2 ring	.2373-.2437	
	No. 3 ring	.2158-.2173	
	No. 4 ring	None	

* Max. bhp (brake horsepower) and max. torque corrected to 60° F and 29.92 in. Hg atmospheric pressure.

(a) Measured 2.20 from top of piston

AMA Specifications—Passenger Car

MAKE OF CAR CORVETTE MODEL YEAR 1968 DATE ISSUED 10-15-67 REVISED (a)

MODEL 19400 427 Cu. In. V-8
430 HP Opt. (L88)

ENGINE—RINGS

Function (top to bottom)	No. 1, oil or comp.	Compression
	No. 2, oil or comp.	Compression
	No. 3, oil or comp.	Oil
	No. 4, oil or comp.	None
Compression	Description - material, coating, etc.	Cast alloy iron; barrel face; no bevel; molybdenum inlay
	Width	.0620-.0625
	Gap	.015-.025
Oil	Description - material, coating, etc.	Multi-piece (2 rails and one spacer expander) Rails-steel, chrome plated OD Expander - stainless steel
	Width	.1870-.1890
	Gap	.010-.030
Expanders		In oil ring assembly

ENGINE—PISTON PINS

Material	Chromium Steel	
Length	2.930-2.905	
Diameter	.9895-.9898	
Type	Locked in rod, in piston, flooring, etc.	Locked in rod
	Bush- ing	None
Clearance	In piston	.00030-.00040
	In rod	None
Direction & amount offset in piston		On center

ENGINE—CONNECTING RODS

Material	High alloy steel	
Weight (oz.)	27.84	
Length (center to center)	6.130-6.140	
Bearing	Material & Type	Premium aluminum
	Overall length	.857
	Clearance (limits)	.0014-.0034
	End play	.016-.020

AMA Specifications—Passenger Car

MAKE OF CAR CORVETTE MODEL YEAR 1968 DATE ISSUED 10-15-67 REVISED (e)MODEL 19400427 Cu. In. V-8
430 HP Opt. (L88)

ENGINE - CRANKSHAFT

Material	Forged steel		
Vibration damper type	Rubber mounted inertia		
End thrust taken by bearing (No.)	Five		
Crankshaft end play	.006-.010		
Main bearing	Material & type	Premium aluminum except No. 5 is sintered copper nickel backed babbitt.	
	Clearance	#1, 2, 3, & 4 - (.0013-.0025); #5 - (.0015-.0031)	
	Journal dia. and bearing overall length	No. 1	2.7510 x .992
		No. 2	2.7510 x .992
		No. 3	2.7505 x .992
		No. 4	2.7505 x .992
		No. 5	2.7506 x 1.2525
		No. 6	None
No. 7		None	
Dir. & amt. cyl. offset	None		
Crankpin journal diameter	2.199- 2.200		

ENGINE - CAMSHAFT

Location	In block above crankshaft		
Material	Cast alloy iron		
Bearings	Material	Steel backed babbitt	
	Number	Five	
Type of Drive	Gear or chain	Chain	
	Crankshaft gear or sprocket material	Steel sprocket	
	Camshaft gear or sprocket material	Cast aluminum	
	Timing chain	No. of links	50
		Width	.880
		Pitch	.550

ENGINE - VALVE SYSTEM

Hydraulic lifters (Std., opt., NA)	Not available	
Valve rotator, type (intake, exhaust)	None	
Rocker ratio	1.70:1	
Operating tappet clearance (indicate hot or cold)	Intake	.024
	Exhaust	.028

(Continued)

AMA Specifications—Passenger Car

TYPE OF CAR CORVETTE MODEL YEAR 1968 DATE ISSUED 10-15-67 REVISED (6)

MODEL 19400 427 Cu. In. V-8
430 HP Opt. (L88)

ENGINE - VALVE SYSTEM (cont.)

SEE CHOP MAN FOR DETAIL

Intake - .3256"
Exhaust - .3412" T.COZ

Timing (based on top of ramp points)	Intake	Opens (°BTC)	62°	
		Closes (°ABC)	105°	
		Duration - deg.	347°	
	Exhaust	Opens (°BBC)	110°	
		Closes (°ATC)	74°	
		Duration - deg.	364°	
Valve opening overlap			136°	
Intake	Material Alloy steel; aluminized face and chrome flash stem			
	Overall length 5.204-5.224			
	Actual overall head dia. 2.185-2.195			
	Angle of seat & face 46° (seat) 45° (face)			
	Seat insert material Nickel Moly Alloy			
	Stem diameter .3715-.3722			
	Stem to guide clearance .0010-.0027			
	Lift (± zero lash) .5586			
	Outer spring press. & length	Valve closed (lb. @ in.)	69-81 @ 1.88	
		Valve open (lb. @ in.)	181-205 @ 1.32	
	Inner spring press. & length	Valve closed (lb. @ in.)	37-45 @ 1.78	
		Valve open (lb. @ in.)	92-110 @ 1.22	
	Exhaust	Material High alloy steel; aluminized face		
		Overall length 5.345-5.365		
Actual overall head dia. 1.835-1.845				
Angle of seat & face 46° (seat) 45° (face)				
Seat insert material Nickel Moly Alloy				
Stem diameter .3713-.3720				
Stem to guide clearance .0015-.0032				
Lift (± zero lash) .5800				
Outer spring press. & length		Valve closed (lb. @ in.)	69-81 @ 1.88	
		Valve open (lb. @ in.)	181-205 @ 1.32	
Inner spring press. & length		Valve closed (lb. @ in.)	37-45 @ 1.78	
		Valve open (lb. @ in.)	92-110 @ 1.22	

ENGINE - LUBRICATION SYSTEM

Type of lubrica- tion (splash, pressure, etc)	Main bearings		Pressure
	Connecting rods		Pressure
	Piston pins		Splash
	Camshaft bearings		Pressure
	Tappets		Pressure
	Timing gear or chain		Centrifugally oiled from camshaft bearing
	Cylinder walls		Pressure, jet cross sprayed

(Continued)

AMA Specifications—Passenger Car

MAKE OF CAR CORVETTE MODEL YEAR 1968 DATE ISSUED 10-15-67 REVISED (a)MODEL 19400427 Cu. In. V-8
430 HP Opt. (L88)

ENGINE - LUBRICATION SYSTEM (cont.)

Oil pump type	Gear
Normal oil pressure (lb. engine rpm)	50-75 PSI @ 2000 (A)
Oil press. sending unit (elect. or mech.)	Electric
Type oil intake (floating, stationary)	Stationary
Oil filter system (full flow, part., other)	Full flow
Filter replacement (element, complete)	Element
Capacity of oil case, less filter-refill (qt.)	5
Oil grade recommended (SAE viscosity and temperature range)	* 32°F. and above - SAE 20W, SAE 10W-30 0°F. to 32°F. *- SAE 10W or SAE 10W-30 Below 0°F. - SAE 5W or SAE 5W-20 * (SAE 5W-30 may be used at temperature below freezing)
Engine Service Reqmt. (MM, MS, etc.)	MS or DG

ENGINE - EXHAUST SYSTEM

Type (single, single with cross-over, dual, other)	Dual	
Muffler No. & type (reverse flow, straight thru, separate resonator)	Two, reverse flow	
Exhaust pipe dia. (O.D. & wall thick.)	Branch	2.50 x .072-.092
	Main	2.50 x .084-.014 laminated
Tail pipe dia. (O.D. & wall thickness)	2.62 x .062-.072	

ENGINE - CRANKCASE VENTILATION SYSTEM

Type (ventilates to atmos., induction system, other)	Standard	Induction System
	Optional	--
Control Unit	Make and model	AC Spark Plug 6424250
	Location	Left front of rocker cover
	Energy source (manifold vacuum, carburetor air stream, other)	Manifold vacuum
	Control method (variable orifice, fixed orifice, other)	Variable orifice
Complete system	Discharges (to intake manifold, carb. air intake, air cleaner intake, other)	Intake manifold
	Air inlet (breather cap, carburetor air cleaner, other)	Carburetor air cleaner
	Flame arrestor (screen, check valve, other)	Screen

A - Bench test - no flow condition.

AMA Specifications—Passenger Car

MAKE OF CAR CORVETTE MODEL YEAR 1968 DATE ISSUED 10-15-67 REVISED ^(*)MODEL 19400 427 Cu. In. V-8
430 HP - Manual Transmission

ENGINE - EXHAUST EMISSION CONTROL

Type (Air injection, engine modifications, other)		Air Injection	
Air Injection Pump	Type	Semi-articulated vane type	
	Displacement	19.3 cubic inches	
	Drive ratio	1.15:1	
	Drive type	Crankshaft pulley	
	Relief valve (type)	Pressure (plate type)	
Filter (describe)		Centrifugal air cleaner	
Air Injection System	Air distribution (head, manifold, etc.)	Manifold	
	Point of entry	Exhaust ports	
	Injection tube I.D.	.2565	
	Check valve type	Pressure (plate type)	
Backfire protection (type)		Diverter valve	
Carburetor	Make	Holley	
	Model	3925519	
	Barrel size	1.75 primary & secondary	
	Idle speed	Drive	1000
		Neutral	--
Idle A/F mixture		Not specified	
Aux. Adv. Systems (type)		None	
Make		Delco Remy	
Model		1111295	
Distributor	Centrifugal adv. in crank degrees @ eng. rpm	Start (rpm)	5000
		Intermed. points deg. @ rpm	18 @ 1900
		Max. deg. @ rpm	30 @ 5000
Vacuum adv. in crank degrees @ eng. rpm	Start (in Hg)	Intermed. points deg. @ in. Hg	None
		Max. deg. @ in.	None
		Vacuum Source	Carburetor
Timing - Crank degrees @ rpm		12 BTDC @ Idle	
Cooling System (describe changes)		None	
Exhaust System (describe changes)		None	

AMA Specifications—Passenger Car

NAME OF CAR CORVETTE MODEL YEAR 1968 DATE ISSUED 10-15-67 REVISED (*)

MODEL 19400 427 Cu. In. V-8
430 HP Opt (L88)

ENGINE - FUEL SYSTEM

(See supplemental page for Details of Fuel Injection, Supercharger, etc. if used)

Induction type: Carburetor, fuel injection, supercharger.		Carburetor	
Fuel Tank	Refill capacity (U.S. gals.)	20 (approximately)	
	Filler location	Center at rear deck	
Fuel Pump	Type (elec. or mech.)	Mechanical	
	Locations	Lower right front of engine	
	Pressure range	5.00-6.50 PSI	
Vacuum booster (std., optional, none)		None	
Fuel Filter	Type	Fine mesh plastic strainer in gas tank and paper filter in carburetor inlet	
	Locations	Automatic	
Carburetor	Choke type	Exhaust	
	Intake manifold heat control (exhaust or water)	Oil-wetted paper element	
	Air cleaner type	Standard	None
		Optional	1000
	Idle speed (spec. neutral or drive)	Manual	--
Automatic		Not specified	
	Idle A/F mix.	Not specified	

CARBURETOR SUPPLEMENTARY INFORMATION

Model Usage	Engine Displ.	Transmission	Carburetors		No. Used and Type	Barrel Size
			Make	Model		
19400	427	4-Speed	Holley	3925519	One; 4-bbl	1.750 Primary & Secondary

AMA Specifications—Passenger Car

MAKE OF CAR CORVETTE MODEL YEAR 1968 DATE ISSUED 10-15-67 REVISED (*)

MODEL 19400

427 Cu. In. V-8

430 HP Opt (L38)

ENGINE - COOLING SYSTEM

Type system (pressure, pressure vented, atmospheric, other)		Pressure	
Radiator cap relief valve pressure		15 ± 1 PSI	
Circulation thermostat	Type (choke, bypass)	Choke	
	Starts to open at (°F)	192°-198°	
Water pump	Type (centrifugal, other)	Centrifugal	
	GPM @ 1000 pump rpm	82 @ 5200	
	Number of pumps	One	
	Drive (V-belt, other)	V-Belt	
	Bearing type	Double row ball	
By-pass recirculation type (inter., ext.)		External	
Radiator core type (cellular, tube and fin, other)		Cross flow	
Cooling system capacity	With heater (qt.)	22	
	Without heater (qt.)	21	
	Opt. equipment-specify (qt.)	--	
Water jackets full length of cyl. (yes, no)		Yes	
Water all around cylinder (yes, no)		Yes	
Radiator hose	Lower	Number and type (molded, straight)	One, molded
		Inside diameter	1.88
	Upper	Number and type (molded, straight)	One, molded
		Inside diameter	1.50
	By-pass	Number and type (molded, straight)	One, molded
		Inside diameter	.725-.765
Fan	Number of blades & spacing	5 Staggered	
	Diameter	17.50	
	Ratio-fan to crankshaft rev.	.949:1	
	Fan cutout type	Thermo-modulated-viscous coupling	
	Bearing type	Double row ball	
*Drive belts (indicate belt used by letter)	Fan	AB	
	Generator or alternator	A	
	Water Pump	B	
	Power Steering	NA	
	Air Conditioning	NA	

* Drive Belt Dimensions	A	B	C	D	E	F	G	H	I	J	K
Angle of V	38°	42°									
Nominal length (SAE)	56.00	34.40									
Width		.380									

AMA Specifications—Passenger Car

MAKE OF CAR CORVETTE MODEL YEAR 1968 DATE ISSUED 10-15-67 REVISED (*)MODEL 19400

427 Cu. In. V-8

430 HP Opt (L88)

ELECTRICAL – SUPPLY SYSTEM

Battery	Make and Model		Delco-Remy 1980087	
	Voltage Rtg. & Total Plates		12 volt-78 plate	
	SAE Designation & Amp. Hr. Rtg.		62 amp/hr @ 20 hr. rate	
	Location		Behind driver seat in stowage compartment	
Terminal grounded		Negative		
Generator or Alternator	Make		Delco-Remy	
	Model		1100696	
	Type and rating		Diode rectified 9-37 amps	
	Output at engine idle (neutral)		24 amps	
Ratio—Gen. to Cr./s rev.		2.46:1		
Regulator	Make		Delco-Remy	
	Model		1119515	
	Type		Vibrator	
	Cutout relay	Closing voltage generator rpm	None	
		Reverse current to open	None	
	Regu- lated	Voltage	13.8-14.8 @ 85°F	
		Current	--	
Voltage test conditions	Temperature	Operating		
	Load	3-8 amperes		
	Other	None		

ELECTRICAL – STARTING SYSTEM

Starting Motor	Make		Delco-Remy	
	Model		1107365	
	Rotation (drive end view)		Clockwise	
Motor control	Switch (solenoid, manual)		Solenoid	
	Starting procedure		4-Spd-Place gearshift lever in neutral & depress clutch INITIAL START-Press accelerator to floor & release. Turn ignition to START, release as soon as engine starts.	
Motor Drive	Engagement type		Position shift solenoid	
	Pinion meshes (front, rear)		Rear	
	Number of teeth	Pinion	9	
		Flywheel	Manual	168
			Auto.	NA
	Flywheel tooth face width	Manual	.4100-.4220	
Auto.		NA		

AMA Specifications—Passenger Car

MAKE OF CAR CORVETTE MODEL YEAR 1968 DATE ISSUED 10-15-67 REVISED (*)

MODEL 19400

427 Cu. In. V-8
430 HP Opt (L88)

ELECTRICAL - IGNITION SYSTEM

Type	Conventional - Std., Opt., N.A.		NA
	Transistorized - Std., Opt., N.A.		Standard
	Other (specify)		None
Coil	Make		Delco-Remy
	Model		1115287
	Amps	Engine stooped	4.0
		Engine idling	1.8
Distributor	Make		Delco-Remy
	Model		1111295
	Cent'gal adv. in c/shaft degrees @ engine rpm (nominal)	Start (rpm)	1200
		Intermediate points deg. @ rpm	18 @ 1900
		Max. deg. @ rpm	30 @ 5000
	Vacuum adv. in c/shaft degrees @ in. Hg. (nominal)	Start (in. Hg.)	None
		Intermediate points, deg. @ in. Hg.	None
		Max. deg. in. Hg.	None
Timing	Breaker gap (in.)		Magnetic
	Cam angle (deg.)		Pulse
	Breaker arm tension (oz.)		Amplifier
	Crankshaft deg. @ rpm		12 BTC at idle
	Mark location		Torsional damper
	Spark Plug	Make	
Model		AC43N	
Thread (mm)		14	
Tightening torque (lb. ft.)		25	
Gap		.033-.038	
Cable	Conductor type		Linen core impregnated with electrical conducting
	Insulation type		Rubber with neoprene jacket
	Spark plug protector		Hypalon jacket

ELECTRICAL - SUPPRESSION

Locations & type Non-metallic, high tension ignition

AMA Specifications—Passenger Car

MAKE OF CAR CORVETTE MODEL YEAR 1968 DATE ISSUED 10-15-67 REVISED (e)MODEL 19400 427 Cu. In. V-8
430 HP Opt. (L88)

ELECTRICAL - INSTRUMENTS AND EQUIPMENT

Speedometer	Type	Dial
	Trip odometer (yes,no)	Yes
Charge indicator - type		Ammeter
Temperature indicator - type		Electric gauge
Oil pressure indicator - type		Bourdon tube gauge
Fuel indicator - type		Electric gauge
Other		Mechanical tachometer
Windshield wiper	Type - Standard	Electric two-speed
	Type - Optional	None
Windshield washer	Type - Standard	Push-button
	Type - Optional	None
Horn	Type	Vibrator
	Number used	Two
	Amp draw (each)	(Low note) 4.5-6.5 @ 12.5V. (Hi note) 4.2-6 @ 12.5V.

DRIVE UNITS - CLUTCH (Manual Transmission)

Make & type	4-Speed Chevrolet, single dry disc. semi-centrifugal	
Type pressure plate springs	Circular plate diaphragm, bent finger design	
Total spring load (lb.)	2600-2800	
of clutch driven discs	One	
Clutch facing	Material	Premium grade woven type asbestos
	Outside & inside dia.	11.00 & 6.50
	Total eff. area (sq.in.)	123.70
	Thickness	.140 each
	Engagement cushioning method	Flat spring steel between cushions
Release bearing	Type & method of lubrication	Single row ball, packed and sealed
Torsional damping	Methods: springs, friction material	Coil, springs

AMA Specifications—Passenger Car

TYPE OF CAR CORVETTE MODEL YEAR 1968 DATE ISSUED 10-15-67 REVISED (a)MODEL 19400 427 Cu. In. V-8
430 HP Opt (L88)

DRIVE UNITS – TRANSMISSIONS

Manual 3-speed (std. or opt.)	Not available
Manual 4-speed (std. or opt.)	Optional
Manual with overdrive (std. or opt.)	Not available
Automatic (std. or opt.)	Not available

DRIVE UNITS – MANUAL TRANS.

Number of forward speeds	4		
	4-Speed		
Transmission ratios	In first	2.20	
	In second	1.64	
	In third	1.27	
	In fourth	1.00	
	In reverse	2.26	
Synchronous meshing, specify gears	All forward gears		
Shift lever location	Floor mounted		
Lubricant	Capacity (pt.)	3	
	Type recommended	Military spec. MIL-L-2105-B	
	SAE viscosity number	Summer	SAE 80
		Winter	SAE 80
		Extreme cold	SAE 80

DRIVE UNITS – MANUAL TRANS. W/OVERDRIVE

(For transmission data see manual transmission section)

Type (planetary or other)			
Manual lockout (yes, no)			
Downshift accelerator control (yes, no)			
Minimum cut-in speed	Not		
Gear ratio			
Lubricant	Capacity (qt.) (Overdrive only)	Available	
	Separate filler (yes, no)		
	Type recommended		
	SAE viscosity number	Summer	
		Winter	
Extreme cold			

AMA Specifications—Passenger Car

MAKE OF CAR CORVETTE MODEL YEAR 1968 DATE ISSUED 10-15-67 REVISED (e)MODEL 19400

DRIVE UNITS — AUTOMATIC TRANSMISSION - NOT AVAILABLE

Trade name		
Type describe		
Selector location		
List gear ratios Selector Pattern and indicate which are used in each selector position		
Max. upshift speed—drive range		
Max. kickdown speed—drive range		
Torque converter	Number of elements	
	Max. ratio at stall	
	Type of cooling (air, liquid)	
	Nominal diameter	
Lubricant	Capacity—refill (pt.)	
	Type recommended	
Special transmission features		

DRIVE UNITS — PROPELLER SHAFT

Number used		One
Type (straight tube, tube-in-tube, internal-external damper, etc.)		Straight tube
Outer diam. x length* x wall thickness	Manual 3-speed trans.	Not available
	Manual 4-speed trans.	2.00 x 29.90 x .095
	Overdrive transmission	Not available
	Automatic transmission	Not available

* Center to center of universal joints, or to centerline of rear attachment.

(Continued)

AMA Specifications—Passenger Car

TYPE OF CAR CORVETTE MODEL YEAR 1968 DATE ISSUED 10-15-67 REVISED (*)

MODEL 19400

DRIVE UNITS — PROPELLER SHAFT (cont.)

Intermediate bearing	Type (plain, anti-friction)	None
	Lubrication (fitting, prepack)	--
Slip Yoke	Type	Yoke
	Number of teeth	27
	Spline O.D.	1.1750
Universal joints	Make and Mfg. No.	Chevrolet, 3868728
	Number used	Two
	Type (ball and trunnion, cross)	Cross
	Rear attach. (u-bolt, clamp, etc.)	V-Belt
	Bearing	Type (plain, anti-friction)
Lubric. (fitting, prepack)		Prepack
Drive taken through (torque tube, ms, springs)		Torque control arms
Torque taken through (torque tube or arms, springs)		Torque control arms

DRIVE UNITS — AXLE

Type (front, rear)	Rear		
Description	Semi-floating, overhung pinion gear		
Limited Slip differential, type	Dual disc clutches		
Drive Pinion Offset	1.5		
No. of differential pinions	2		
Pinion adjustment (shim, other)	None		
Pinion bearing adj. (shim, other)	Shim		
Wheel bearing type	Taper roller		
Lubricant	Capacity (pt.)	3.7	
	Type recommended	Meeting Military Specs MIL-L-2105-B	
	SAE viscosity number	Summer	SAE 80
		Winter	SAE 80
Extreme cold		SAE 80	

AXLE RATIO TOOTH COMBINATIONS

(See page 3 for axle ratio usage)

Axle ratio	3.36	3.55	3.70	4.11	4.56	
No. of teeth	Pinion	11	9	10	9	9
	Ring gear	37	32	37	37	41
Gear O.D.	8.375					

AMA Specifications—Passenger Car

NAME OF CAR CORVETTE MODEL YEAR 1968 DATE ISSUED 10-15-67 REVISED (•)

MODEL 19400

DRIVE UNITS – WHEELS

Type & material		Short spoke disc steel	
Rim (size & flange type)	Std.	15 x 7 JK	
	Opt.	None	
Attachment	Type (bolt or stud)	Stud	
	Circle diameter	4.75	
	Number and size	5 Hex nuts 7/16-20 UNF 2-B	

MODEL _____

DRIVE UNITS – TIRES

Standard	Size, ply rating, & ply		F 70 x 15-2 ply (4 ply rating)
	Type (bias, radial, etc.)		Bias
	Full rated Inflation Press.	Front	24
		Rear	24
	Rev./Mile at 50 MPH		776
Optional	Size, ply rating, & ply		None

BRAKES – PARKING

Type of control		Grip handle control
Location of control		Center of floor console
Operates on		Rear wheels
If separate from service brakes	Type (internal or external)	Internal
	Drum diameter	6.5
	Lining size (length x width x thickness)	6.78 x 1.25 x .175

AMA Specifications—Passenger Car

MAKE OF CAR CORVETTE MODEL YEAR 1968 DATE ISSUED 10-15-67 REVISED (*)MODEL 19400

BRAKES—SERVICE

Type (drum or disc)		Caliper disc, 4-wheel hydraulic		
Self adjusting (std., opt., N.A.)		Standard		
Power brake make & type (remote, int., etc.)	Std.	--		
	Opt.	Delco-Moraine vacuum power unit; integral		
Effective area (sq. in.)*		78.1		
Gross lining area (sq. in.)**		86.3		
Swept area (sq. in.)***		461.2		
Percent brake effectiveness—front		65		
Drum or Disc	Diameter (nominal)	Front	11.75 x 1.25	
		Rear	11.75 x 1.25	
Drum or Disc	Type and material		Cast iron	
	Disc (vented or solid)		Vented	
	No. pistons per caliper		4	
Wheel cylinder bore	Front	1.875		
	Rear	1.375		
Master Cylinder	Bore		1.00	
	displacement distribution	Front %	65	
		Rear %	35	
Proportioning valve	Type (proportion, delay, metering, other)		Check valve	
Pedal arc ratio		4.52		
Line pressure at 100 lb. pedal load		576		
Shoe clearance adjustment		Self-adjusting		
Brake lining	Drum or Disc		Disc	
	Bonded or riveted		Riveted	
	Front Wheel	Material		Woven asbestos
		Size (length x width x thickness)	Prim. or out-board	5.96 x 2.21 x .41
			Second. or in-board	5.96 x 2.21 x .41
		Segments per shoe		One
	Rear Wheel	Material		Woven asbestos
Size (length x width x thickness)		Prim. or out-board	5.96 x 2.21 x .41	
		Second. or in-board	5.96 x 2.21 x .41	
Segments per shoe		One		

* Excludes rivet holes, grooves, chamfers, etc. ** Includes rivet holes, grooves, chamfers, etc.

*** Total swept area for four brakes. (Widest lining contact width for each brake x its contact circumference.)

AMA Specifications—Passenger Car

MAKE OF CAR CORVETTE MODEL YEAR 1968 DATE ISSUED 10-15-67 REVISED (a)

MODEL 19400

STEERING

Manual (std., opt., NA)		Standard		
Power (std., opt., NA)		--		
Adjustable steering wheel (tilt, swing, other)	Type and description	Telescopic steering column; 3" adjustment		
	(std., opt., NA)	Optional		
Wheel diameter	Manual	16.0		
	Power	16.0		
Turning diameter (feet)	Outside front	Wall to wall (l. & r.)		
		Curb to curb (l. & r.)		
	Inside rear	Wall to wall (l. & r.)		
		Curb to curb (l. & r.)		
Outside whl. angle with inside whl. at 20°		18.47		
Manual	Gear	Type	Semi-reversible, recirculating ball nut	
		Make	Saginaw	
	Ratios	Gear	16.0:1	
		Overall	20.2:1	
No. wheel turns		3.4		
Power	Type (coaxial, linkage, etc.)			
	Make		Not	
	Gear	Type	--	
		Ratios	Gear	--
			Overall	Available
	Pump driven by		--	
Number wheel turns		--		
Linkage	Type		Parallelogram	
	Location (front or rear of wheels, other)		Rear	
	Drag link (trans. or longit.)		None	
	Tie rods (one or two)		Two	
Steering Axis	Inclination at camber (deg.)		6-1/2 to 7-1/2	
	Bearings (type)	Upper	Ball stud with non-metallic bearing surface	
		Lower	Ball stud with non-metallic bearing surface	
		Thrust	None	
Whl. Align. (range at curb wt. & preferred)	Caster (deg.)		P1/2 to P1-1/2	
	Camber (deg.)		P1/4 to P1-1/4 (a)	
	Toe-in (outside track inches)		3/32 to 5/32 (a)	
Steering spindle & joint type		Steering knuckle with spherical joint		
Wheel Spindle	Diameter	Inner bearing	1.2493-1.2498	
		Outer bearing	.7492-.7497	
	Thread size		3/4-20 NEF - 3 (Modified)	
	Bearing type		Taper roller	

(a) Rear wheel alignment: N 1-3/8 to N 3/8
Toe-In 1/32 to 3/32

AMA Specifications—Passenger Car

MAKE OF CAR CORVETTE MODEL YEAR 1968 DATE ISSUED 10-15-67 REVISED (*)MODEL 19400 12400

SUSPENSION — GENERAL

(See Supplement page for details on Air Suspension)

Provision for car leveling	Front stabilizer bar	
Provision for brake dip control	Mounting angle of front upper control arm	
Provision for acc. squat control	None	
Special provisions for car jacking	Front: 5" forward of front edge of door opening, under frame. Rear: 3" forward of wheel opening, under frame.	
Shock absorber front & rear	Type	Direct, double acting hydraulic
	Make	Delco
	Piston dia.	1.00
Other special features		

SUSPENSION — FRONT

Type and description	Independent: SLA type with coil spring and concentric shock absorber, and spherically-jointed steering knuckle for each wheel	
Spring	Type	Coil
	Material	Steel alloy
	Size (coil design height & I.D. bar length x dia.)	9.99 x 3.80 138.75 x .618
	Spring rate (lb. per in.)	284
	Rate at wheel (lb. per in.)	
Stabilizer	Type (link, linkless, frameless)	Link
	Material & bar diameter	Steel .9375

SUSPENSION — REAR

Type and description	(A)	
Drive and torque taken through	Torque control arms	
Spring	Type	Multi-leaf
	Material	Chrome carbon steel
	Size (length x width, coil design height & I.D.; bar length & dia.)	46.36 x 2.25
	Spring rate (lb. per in.)	140
	Rate at wheel (lb. per in.)	123
	Mounting insulation type	Rubber mounted at differential; Vertical loading only at shack
If leaf	No. of leaves	9
	Shackle (comp. or tens.)	Tension
Stabilizer	Type (link, linkless, frameless)	Link
	Material	.562
Track bar type	None	

A - Full independent with fixed differential, transverse multi-leaf spring, lateral struts and universally-jointed axle shafts



1

2

3

4



AMA Specifications—Passenger Car

CAR AND BODY DIMENSIONS

KEY SHEET

EXTERIOR CAR AND BODY DIMENSIONS

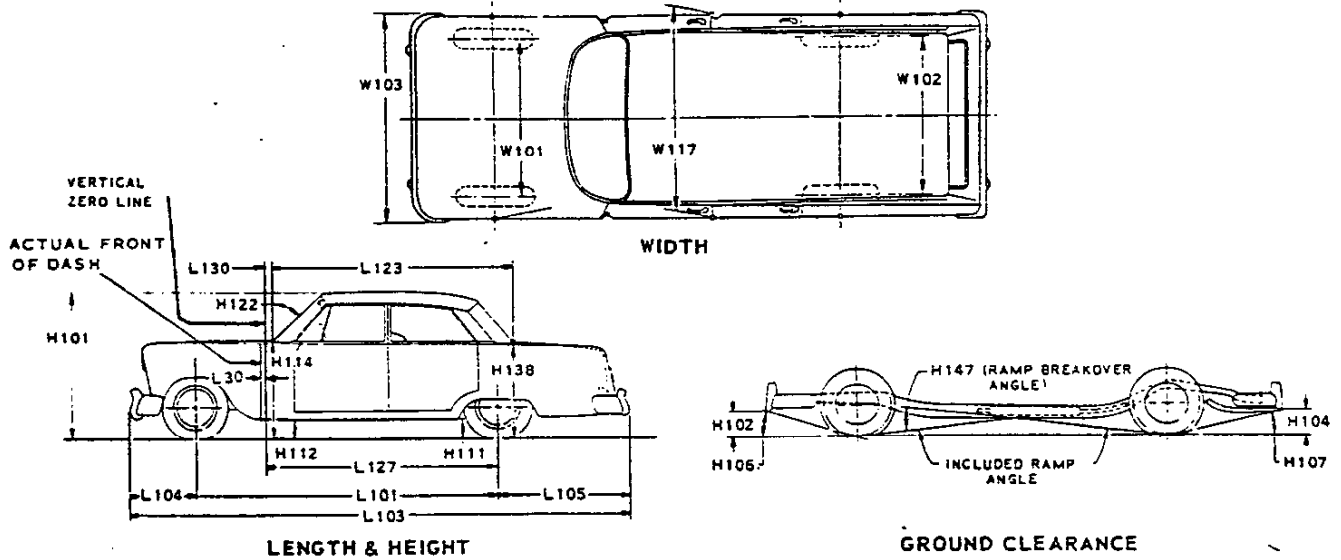

INTERIOR CAR AND BODY DIMENSIONS

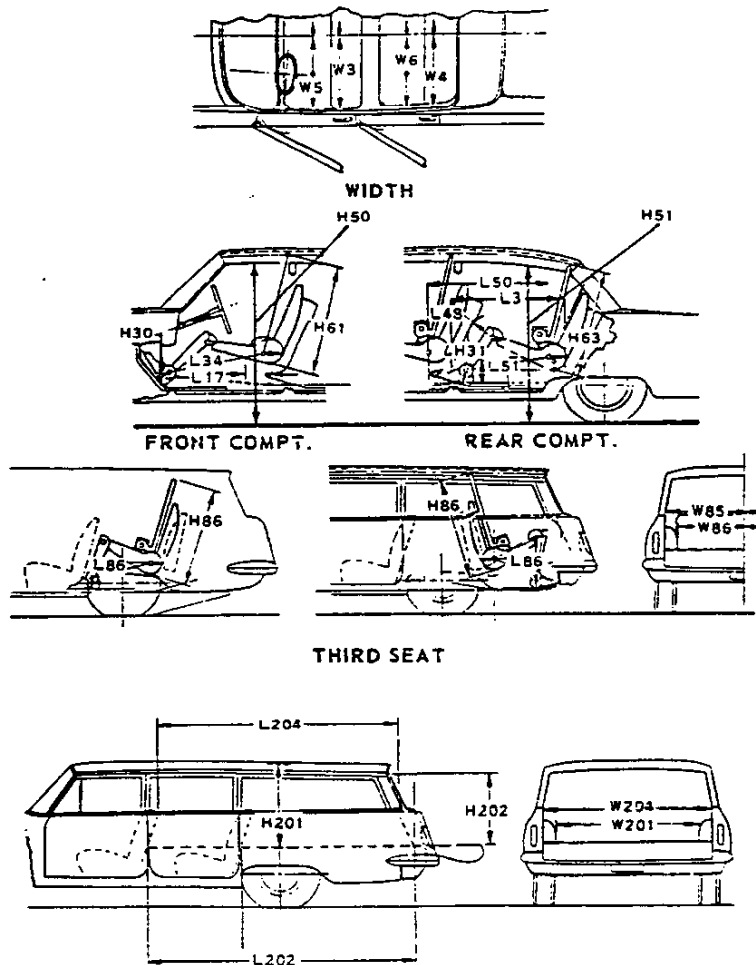



1
2

3
4
5

6



INDEX

SUBJECT	PAGE NO.	SUBJECT	PAGE NO.
Automatic Transmission	16	Kingpin (Steering Axis)	20
Axis, Steering	20	Lamp height and spacing	23
Axle, Rear	17	Legroom	2
Battery	12	Lengths - Car and Body	1
Bearings, Engine	5, 6, 7	Lifters, valve	6
Belts - Fan, Generator, Water Pump	11	Linings - Clutch, Brake	14, 19
Brakes - Parking, Service Power	18, 19	Lubrication	7, 8, 14, 15, 16, 17
Camber	20	Luggage Compartment	2
Camshaft	6	Motor, Starting	12
Capacities		Muffler	8
Cooling System	11	Overdrive	15
Fuel Tank	10	Piston Pins & Rings	4, 5
Lubricants		Pistons	4, 5
Engine Crankcase	8	Power Brakes	19
Transmission and Overdrive	15, 16	Power Steering	20
Rear Axle	17	Power Teams	3
Car and Body Dimensions		Propeller Shaft, Universal Joints	16, 17
Width	1	Pumps - Oil, Fuel	8, 10
Length	1	Water	11
Height	1	Radiator, Hoses	11
Ground Clearance	1	Ratios - Axle	3, 17
Front Compartment	2	Compression	3, 4
Rear Compartment	2	Steering	20
Luggage Compartment	2	Transmission	15, 16
Station Wagon - Third Seat	2	Rear Axle	3, 17
Station Wagon - Cargo Space	2	Regulator - Generator	12
Carburetor	3, 9, 10	Rims	18
Caster	10	Rings, Piston	5
Lock, Automatic	10	Rods - Connecting	5
Lock - Pedal Operated	14	Shack Absorbers, Front & Rear	21
Coil, Ignition	13	Spark Plugs	13
Connecting Rod	5	Speedometer	14
Convenience Equipment	23	Springs - Front & Rear Suspension	21
Cooling System	11	Valve, Engine	6
Crankcase Ventilation System	8	Stabilizer (Sway Bar) - Front & Rear	21
Crankshaft	6	Starting System	12
Cylinders and Cylinder Head	4	Steering	20
Dimension Definitions		Supply System	12
Key Sheet	25	Suppression - Ignition, Radio	13
Exterior & Interior	26	Suspension - Front & Rear	21
Distributor - Ignition	13	Tail Pipe	9
Electrical System	12, 13, 14	Thermostat, Cooling	11
Engine		Timing, Engine & Valve	6, 7, 13
Bore, Stroke, Displacement, Type	4	Tires	18
Compression Ratio	4	Tie in	20
Firing Order, Cylinder Numbering	4	Torque Converter	16
General Information, H.P. & Torque	4	Torque - Engine, Rated	3, 4
Lubrication	7, 8	Transmission - Types	3, 10, 15, 16
Power Teams	3	Automatic	3, 10, 15, 16
Exhaust Emission Control	9	Manual & Overdrive	3, 10, 15
Exhaust System	8	Ratios	15, 16
Equipment Availability	22	Track	1
Fan, Cooling	11	Trunk Luggage Capacity	2
Filters - Engine Oil, Fuel System	8, 10	Turning Diameter	20
Frame	22	Unitized Construction	22
Front Suspension	21	Universal Joints, Propeller Shaft	16, 17
Fuel, Fuel Pump, Fuel System	4, 10	Valves - Intake & Exhaust	6, 7
Fuel Injection	10	Vibration Damper	6
Generator and Regulator	12	Voltage Regulator	12
Glass	22	Water Pump	11
Light (Lamps)	14	Weights - Shipping, Curb	24
Loadroom - Body	2	Wheel Alignment	20
Weights - Car and Body	1	Wheelbase	1
Horns	14	Wheels & Tires	15
Horsepower - Brake	3, 4	Wheel Spindle	20
Ignition System	13	Widths - Car and Body	1
Inflation - Tires	18	Windshield	22
Instruments	14	Windshield Wiper	14



.

.

.

.

.

.



1968 CORVETTE

Production: 9,836 coupe, 18,630 convertible, 28,566 total.

1968 NUMBERS

Vehicle: 194378S400001 through 194378S428566

* For convertibles, fourth digit is a 6.

Suffix: HE: 327ci, 300hp, mt IO: 427ci, 400hp, at
 HO: 327ci, 300hp, at IO: 427ci, 390hp, at
 HP: 327ci, 350hp, mt, ac, ps IR: 427ci, 435hp, mt
 HT: 327ci, 350hp, mt IT: 427ci, 430hp (L88), mt, ah
 IL: 427ci, 390hp, mt IU: 427ci, 435hp, mt, ah
 IM: 427ci, 400hp, mt

Block: 3914678: 327ci, 300hp, 350hp
 3916321: 427ci, 390hp, 400hp, 430hp, 435hp
 3935439: 427ci, 430hp, 435hp
Head: 3917215: 427ci, 390hp, 400hp 3919840: 427ci, 435hp, lh
 3917291: 327ci, 300hp, 350hp 3919842: 427ci, 430hp, 435hp, ah
 3917292: 327ci, 350hp

Carb: Rochester Q-jet #7028207: 327ci, 300hp, mt
 Rochester Q-jet #7028208: 327ci, 300hp, at
 Rochester Q-jet #7028209: 427ci, 390hp, mt
 Rochester Q-jet #7028216: 427ci, 390hp, at
 Rochester Q-jet #7028219: 327ci, 350hp, mt
 Holley R3559A #3902353: 427ci, 400hp, 435hp, lc, rc
 Holley R4054A #3925519: 427ci, 430hp (L88)
 Holley R4055A #3925517: 427ci, 400hp(cc, mt), 435hp(cc), fd
 Holley R4055-1A #3940929: 427ci, 400hp(cc, mt), 435hp(cc), sd
 Holley R4056A #3902516: 427ci, 400hp, cc, at, fd
 Holley R4056-1A #3940930: 427ci, 400hp, cc, at, sd

Distributor: 1111194: 327ci, 300hp 1111296: 427ci, 435hp, ig
 1111293: 427ci, 390hp, 400hp 1111438: 327ci, 350hp
 1111294: 427ci, 390hp, 400hp, ig 1111441: 327ci, 350hp, ig, fd
 1111295: 427ci, 430hp, ig 1111475: 327ci, 350hp, ig, sd

Alternator: 1106693: 300hp, 350hp, 390hp, 400hp
 1106696: 350hp, 390hp, 400hp, 430hp, 435hp, ig
 1100750: All with ac

Ending Vehicle: Sep 67: 400905 Jan 68: 410386 May 68: 420928
 Oct 67: 403410 Feb 68: 412647 Jun 68: 423978
 Nov 67: 405682 Mar 68: 415000 Aug 68: 428566
 Dec 67: 407922 Apr 68: 417676

Abbreviations: ac=air conditioning, ah=aluminum heads, al=automatic transmission, cc=center carburetor, ci=cubic inch, fc=front carburetor, fd=first design, hp=horsepower, ig=ignition, ih=iron head, mt>manual transmission, ps=power steering, rc=rear carburetor, sd=second design.

1968 FACTS

- The 1968 Corvette exterior and interior were redesigned. Coupes featured removable roof panels and rear window.
- Automatic transmissions changed for 1968 from the two-speed Power-glide to the three-speed Turbo Hydra-Matic.
- Hidden headlights "popped up" into position, rather than rotated. The mechanism was vacuum operated instead of electric as before.
- The battery moved to a compartment behind the seats.
- Windshield wipers were hidden under a vacuum-operated panel.
- Side vent windows were eliminated starting with the 1968 Corvette.

1968 OPTIONS

RPO #	DESCRIPTION	QTY	RETAIL \$
19437	Base Corvette Sport Coupe	9,936	\$4,663.00
19467	Base Corvette Convertible	18,630	4,320.00
A01	Genuine Leather Seats	2,429	79.00
A02	Soft Ray Tinted Glass, all windows	17,635	15.80
A03	Soft Ray Tinted Glass, windshield	5,509	57.95
A31	Power Windows	7,065	42.15
A82	Headrests	3,197	26.35
A85	Custom Shoulder Belts (std with coupe)	350	231.75
C07	Auxiliary Hardtop (for convertible)	8,735	52.70
C08	Vinyl Covering (for auxiliary hardtop)	3,050	31.60
C50	Rear Window Defroster	693	412.90
C60	Air Conditioning	5,664	36.90
F41	Special Front and Rear Suspension	1,758	46.35
G81	Positraction Rear Axle, all ratios	27,008	42.15
J50	Power Brakes	9,559	384.45
J56	Special Heavy Duty Brakes	81	73.75
K66	Transistor Ignition System	5,457	200.15
L36	427ci, 390hp Engine	7,717	305.50
L68	427ci, 400hp Engine	1,932	437.10
L71	427ci, 435hp Engine	2,898	105.35
L79	327ci, 350hp Engine	9,440	947.90
L88	427ci, 430hp Engine	80	805.75
L89	Aluminum Cylinder Heads with L71	624	184.35
M20	4-Speed Manual Transmission	10,760	184.35
M21	4-Speed Man Trans, close ratio	12,337	263.30
M22	4-Speed Man Trans, close ratio, heavy duty	80	226.45
M40	Turbo Hydra-Matic Automatic Transmission	5,063	36.90
N11	Off Road Exhaust System	6,477	42.15
N36	Telescopic Steering Column	12,364	94.80
N40	Power Steering	8,971	57.95
P01	Bright Metal Wheel Cover	11,686	31.30
PT6	Rad Stripe Tires, F70x15, nylon	9,692	26.35
PT7	White Stripe Tires, F70x15, nylon	388	10.55
UA6	Alarm System	3,453	172.75
U15	Speed Warning Indicator	24,609	278.10
U69	AM-FM Radio	3,311	
U79	AM-FM Radio, stereo		

1968 COLORS

CODE	EXTERIOR	QTY	SOFT TOP	INTERIORS
900	Tuxedo Black	708	Bk-W-Bg	Bk-Db-Do-Gu-Mb-R-To
972	Polar White	1,868	Bk-W-Bg	Bk-Db-Do-Gu-Mb-R-To
974	Rally Red	2,918	Bk-W-Bg	Bk-R
976	LeMans Blue	4,722	Bk-W-Bg	Bk-Mb-Db
978	International Blue	2,473	Bk-W-Bg	Bk-Mb-Db
983	British Green	4,779	Bk-W-Bg	Bk
984	Safari Yellow	3,133	Bk-W-Bg	Bk
986	Silverstone Silver	3,435	Bk-W-Bg	Bk-Db-Gu
988	Cordovan Maroon	1,155	Bk-W-Bg	Bk
992	Corvette Bronze	3,374	Bk-W-Bg	Bk-Do-To

- Suggested interiors shown. Other combinations were possible.
- All 1968 wheels were painted silver.
- In 1968, 1 Corvette had non-standard paint, or primer. Interior Codes: Sid=Bk/V, 402=Bk/L, 407=RV, 408=RL, 411=Db/V, 414=Mb/V, 415=Mb/L, 425=Do/V, 426=Do/L, 435=To/V, 436=To/L, 442=Gu/V
- Abbreviations: Bg=Beige, Bk=Black, Db=Dark Blue, Do=Dark Orange, Gu=Gunmetal, L=Leather, Mb=Medium Blue, R=Red, To=Tobacco, V=Vinyl, W=White.



•

•

•

•

•

•



BLACK BOOK ORDER FORM

Send _____ copies of the

Corvette Black Book 1953-1996

@ \$11.95 each \$ _____

Ohio residents add .72 sales tax _____

Postage/hard shipping container 3.00 _____

Check or money order enclosed \$ _____

Name _____

Street _____

City _____

State _____

Zip _____

Mail Order To: **Michael Bruce Associates, Inc.**
Post Office Box 396
Powell, Ohio 43065

BLACK BOOK ORDER FORM

Send _____ copies of the

Corvette Black Book 1953-1996

@ \$11.95 each \$ _____

Ohio residents add .72 sales tax _____

Postage/hard shipping container 3.00 _____

Check or money order enclosed \$ _____

Name _____

Street _____

City _____

State _____

Zip _____

Mail Order To: **Michael Bruce Associates, Inc.**
Post Office Box 396
Powell, Ohio 43065

